

BUILDING MODELING AND IDENTIFICATION FOR
PREDICTIVE CONTROL

SAMUEL PRÍVARA



Doctoral Thesis

Department of Control Engineering
Faculty of Electrical Engineering
Czech Technical University in Prague

2013

Samuel Prívvara: *Building modeling and identification for predictive control*,
Doctoral Thesis, © 2013

PHD PROGRAM:

Electrical Engineering and Information Technology

BRANCH OF STUDY:

Control Engineering and Robotics

SUPERVISOR:

Michael Šebek

*Department of Control Engineering, Faculty of Electrical Engineering, Czech
Technical University in Prague*

SUPERVISOR-SPECIALIST:

Lukáš Ferkl

*Department of Control Engineering, Faculty of Electrical Engineering, Czech
Technical University in Prague*

OPONENTS:

Lieve Helsen

Department of mechanical Engineering, KU Lueven

Roy Smith

Department of Control Engineering, ETH Zürich

Heinz A. Preisig

Department of Chemical Engineering, NTNU Trondheim

TIME FRAME AND LOCATION ARRANGEMENTS:

The doctoral thesis statement was distributed in February 2013. The defence of the doctoral thesis will be held in September 2013 before the Board for the Defense of the Doctoral Thesis in the branch of study Control Engineering and Robotics at Department of Control Engineering in Prague. Those interested may get acquainted with the doctoral thesis concerned at the Dean Office of the Faculty of Electrical Engineering of the CTU in Prague, at the Department for Science and Research, Technická 2, Praha 6.

There are only two ways to live your life. One is as though nothing is a miracle. The other is as though everything is a miracle.

– Albert Einstein

God, if I can not have what I want, let me want what I have.

This work is dedicated to my parents.

DECLARATION

This dissertation is submitted in partial fulfilment of the requirements for the Degree of Doctor (Ph.D.). The doctoral thesis was produced in full-time manner Ph.D. study at the Department of Control Engineering of the Faculty of Electrical Engineering of the Czech Technical University in Prague. The work submitted in this dissertation is the result of my own investigation, except where otherwise stated.

It has not already been accepted for any degree, and is also not being concurrently submitted for any other degree.

Prague, February 2013

Samuel Prívora

FORM

This thesis is not written in a classic format but as a commentary to the attached journal papers. This format of the dissertation thesis is approved by the Dean of Faculty of Electrical Engineering by his 'Directive for dissertation theses defence" (Směrnice Děkana), Article 1.

SUMMARY

Climate changes, diminishing world supplies of the non-renewable fuels as well as economic aspects are probably the most driving factors of current effort to save the energy. As buildings account for about 40 % of global final energy use, an efficient building climate control can significantly contribute to the saving effort. *Predictive building automation* can be used to operate the buildings in energy and cost effective manner instead of conventional automation with minimum retrofitting requirements.

Dynamic models (which must be simple, yet effective) are of crucial importance in predictive control approach. As the industrial experience has shown, the modeling and identification is the most time-demanding and costly part of the overall automation process. Many papers devoted to this topic actually model only the subsystems of a building. Some of them identify a building complex in reality as simple two-zones models. Others provide extremely detailed models resulting from the use of simulation software packages. These models, however, are not suitable for control as they are not in an explicit form.

This thesis deals with the identification and modeling of the buildings resulting in a model suitable for the predictive control. A number of identification and modeling approaches is analyzed with respect to their suitability to use for predictive control of the buildings. Those that appear to be the promising candidates for the Model Predictive Control (MPC) are treated in detail.

A novel approach combining a detailed modeling by a building-design software with a black-box subspace identification is proposed. The uniqueness of the presented approach is not only in the size of the problem, but also in the way of getting the model and interconnecting several computational and simulation tools.

As most of the industrial applications (as well as buildings) are Multiple-Input Multiple-Output (MIMO) systems that can be identified using the knowledge of the system's physics or from measured data employing statistical methods. Currently, there is the only class of statistical identification methods capable of handling the issue

of the vast MIMO systems – Subspace State Space System Identification (s_4 SID) methods. These methods, however, as all the statistical methods, need data of a certain quality, i.e. excitation of the corresponding order, no data corruption, etc. Nevertheless, combination of the statistical methods and a physical knowledge of the system could significantly improve system identification. The thesis presents a new algorithm which provides remedy to the insufficient data quality of a certain kind through incorporation of the prior information, namely a known static gain and an input-output feed-through. The presented algorithm naturally extends classic subspace identification algorithms, that is, it adds extra equations into the computation of the system matrices.

For some kind of buildings, there is a possibility to take the advantage of using the physical structure. Hence, yet another class of modeling approaches, namely grey-box modeling techniques emerges. And as the objective is to have a good predictor on a horizon which is commensurate with the control, a natural choice is Model Predictive Control Relevant Identification (MRI). Some improvements to this identification methodology are suggested in this thesis as well.

Finally, a problem of the model selection is addressed. Very often, there are far too many candidate inputs/states of the analyzed system and one has to decide which of them should be included to maximize the given quality criterion. The effective methodology for the selection of the inputs and states as well as the following model validation are proposed.

The thesis is structured as follows: [Chapter 2](#) presents motivation and provides comments on contributions of this work published in the papers which are available (for pdf version) in [Chapter 3](#) by clicking the corresponding hyperlink. For online version, the hyperlink directs the reader to the list of references with the hyperlink to the internet address. The main results are outlined in [Chapter 4](#) while [Chapter 5](#) concludes the work and outlines directions of possible research. [Chapter 6](#) summarizes the fulfilment of the objectives of the thesis.

PUBLICATIONS

- J. Cigler, S. Prívará, Z. Váňa, E. Žáčková, and L. Ferkl. Optimization of predicted mean vote index within model predictive control framework: Computationally tractable solution. *Energy and Buildings*, 52(0):39 – 49, 2012. ISSN 0378-7788. doi: 10.1016/j.enbuild.2012.05.022. URL <http://www.sciencedirect.com/science/article/pii/S0378778812002770>.
- O. Nývlt, S. Prívará, and L. Ferkl. Probabilistic risk assessment of highway tunnels. *Tunnelling and Underground Space Technology*, 26(1):71–82, 2011. doi: 10.1016/j.tust.2010.06.010. URL <http://www.sciencedirect.com/science/article/pii/S0886779810001057>.
- S. Prívará, J. Široký, L. Ferkl, and J. Cigler. Model predictive control of a building heating system: The first experience. *Energy and Buildings*, 43(2-3):564–572, 2011. doi: 10.1016/j.enbuild.2010.10.022. URL <http://www.sciencedirect.com/science/article/pii/S0378778810003749>.
- S. Prívará, Z. Váňa, E. Žáčková, and J. Cigler. Building modeling: Selection of the most appropriate model for predictive control. *Energy and Buildings*, 55:341–350, December 2012. ISSN 0378-7788. doi: 10.1016/j.enbuild.2012.08.040. URL <http://www.sciencedirect.com/science/article/pii/S0378778812004446?v=s5>.
- S. Prívará, J. Cigler, Z. Váňa, F. Oldewurtel, C. Sagerschnig, and E. Žáčková. Building modeling as a crucial part for building predictive control. *Energy and Buildings*, 56:8–22, January 2013a. ISSN 0378-7788. doi: <http://dx.doi.org/10.1016/j.enbuild.2012.10.024>. URL <http://www.sciencedirect.com/science/article/pii/S0378778812005336?v=s5>.
- S. Prívará, J. Cigler, Z. Váňa, F. Oldewurtel, and E. Žáčková. Use of partial least squares within the control relevant identification for buildings. *Control Engineering Practice*, 21, January 2013b. ISSN 0967-0661. doi: <http://dx.doi.org/10.1016/j.conengprac.2012.09.017>. URL <http://www.sciencedirect.com/science/article/pii/S0967066112002006>.
- J. Široký, F. Oldewurtel, J. Cigler, and S. Prívará. Experimental analysis of model predictive control for an energy efficient building heating system. *Applied Energy*, 88(9):3079–3087, 2011. doi: 10.1016/j.apenergy.2011.03.009. URL <http://www.sciencedirect.com/science/article/pii/S0306261911001668>.

- S. Prívará, J. Cigler, Z. Váňa, and L. Ferkl. Incorporation of system steady state properties into subspace identification algorithm. *International Journal of Modelling, Identification and Control*, 16(2): 159–167, 2012. doi: 10.1504/IJMIC.2012.047123. URL <http://www.inderscience.com/info/inarticle.php?artid=47123>.

INTERNATIONAL CONFERENCES – WOS –
INVITED LECTURES

- L. Ferkl, J. Široký, and S. Prívvara. Model predictive control of buildings: The efficient way of heating. In *2010 IEEE Multi-Conference on Systems and Control*, pages 1922 –1926, September 2010. doi: 10.1109/CCA.2010.5611114.
- S. Prívvara, Z. Váňa, D. Gyalistras, J. Cigler, C. Sagerschnig, M. Morari, and L. Ferkl. Modeling and identification of a large multi-zone office building. In *2011 IEEE International Conference on Control Applications (CCA)*, pages 55–60. IEEE, 2011.

- J. Cigler and S. Prívvara. Subspace identification and model predictive control for buildings. In *Control Automation Robotics & Vision (ICARCV), 2010 11th International Conference on*, pages 750–755. IEEE, 2010.
- J. Cigler, S. Prívvara, Z. Váňa, D Komárková, and M. Šebek. Optimization of predicted mean vote thermal comfort index within model predictive control framework. In *51th IEEE Conference on Decision and Control (CDC)*, December 2012a.
- J. Cigler, S. Prívvara, Z. Váňa, E. Žáčková, and L. Ferkl. On predicted mean vote optimization in building climate control. In *20th Mediterranean Conference on Control & Automation (MED)*, pages 1518–1523. IEEE, 2012b.
- S. Prívvara, J. Cigler, Z. Váňa, L. Ferkl, and M. Šebek. Subspace identification of poorly excited industrial systems. In *49th IEEE Conference on Decision and Control (CDC)*, pages 4405–4410, Dec. 2010. doi: 10.1109/CDC.2010.5717585.
- S. Prívvara, Z. Váňa, J. Cigler, and J. Komárek. Role of mpc in building climate control. In *21st European Symposium on Computer Aided Process Engineering*, volume 29 of *Computer Aided Chemical Engineering*, pages 728 – 732. Elsevier, 2011. doi: DOI:10.1016/B978-0-444-53711-9.50146-2. URL <http://www.sciencedirect.com/science/article/pii/B9780444537119501462>.
- S. Prívvara, Z. Váňa, J. Cigler, and L. Ferkl. Predictive control oriented subspace identification based on building energy simulation tools. In *20th Mediterranean Conference on Control & Automation (MED)*, pages 1290–1295. IEEE, 2012.
- Z. Váňa, S. Prívvara, J. Cigler, and H.A. Preisig. System identification using wavelet analysis. In *21st European Symposium on Computer Aided Process Engineering*, volume 29 of *Computer Aided Chemical Engineering*, pages 763 – 767. Elsevier, 2011. doi: DOI:10.1016/B978-0-444-53711-9.50153-X. URL <http://www.sciencedirect.com/science/article/pii/B978044453711950153X>.
- J. Široký, S. Prívvara, and L. Ferkl. Model predictive control of building heating system. *Proceedings of 10th Rehva World Congress, Clima*, 2010, 2010.

- E. Žáčková and S. Prívvara. Control relevant identification and predictive control of a building. In *Control and Decision Conference (CCDC), 2012 24th Chinese*, pages 246–251. IEEE, 2012.
- E. Žáčková, S. Prívvara, and Z. Váňa. Model predictive control relevant identification using partial least squares for building modeling. In *Australian Control Conference (AUCC), 2011*, pages 422–427. IEEE, 2011.
- E. Žáčková, S. Prívvara, and J. Komárek. On dual control for buildings using persistent excitation condition. In *51th IEEE Conference on Decision and Control (CDC)*, December 2012.

When we honestly ask ourselves which person in our lives mean the most to us, we often find that it is those who, instead of giving advice, solutions, or cures, have chosen rather to share our pain and touch our wounds with a warm and tender hand. The friend who can be silent with us in a moment of despair or confusion, who can stay with us in an hour of grief and bereavement, who can tolerate not knowing, not curing, not healing and face with us the reality of our powerlessness, that is a friend who cares.

— Henri Nouwen

ACKNOWLEDGMENTS

First, I would like to thank to my supervisors Michael Šebek and Lukáš Ferkl for their excellent guidance, support, conditions for research and for sharing their ideas with me.

A special thanks belongs to Vladimír Kučera for his sensible guidance and advice when it was mostly needed and for creating conditions for perfect co-operation.

Then a sincere thanks belong to Jirka Cigler, Zdeněk Váňa for their hints, lots of advice and for sharing so much of their time with me. I thank them for sharing many every-day problems with me. Not to forgotten are the common trips and holidays all over the world, lots of fun, experience and adrenaline as well as our “working Saturdays” for our “enslavers”.

I am grateful for my excellent colleagues Ondra Nývlt, Eva Žáčková, Maťo Pčolka and Honza Šulc for a friendly atmosphere and working conditions I could (almost) always (we had our times, didn't we?) work in. You indeed were the best colleagues I could ever imagine.

I would like to express my deep gratitude to those that enabled my 6 months stay at ETH Zurich, which was one of the most fruitful periods of my life. I really appreciate the guidance and advice of Manfred Morari, Roy Smith during my stay at ETH Zurich. I thank my “Swiss” colleagues Frauke Oldewurtel, David Sturzenegger, Boris L.Vega Lara and others for many fruitful discussions and help in a new environment.

Moreover, I would like to thank to Pepa Komárek and Daja Komárková from Technofiber, s.r.o., Honza Široký, Martin Chlupáč and Petr Kudera from Energocentrum, s.r.o. for a perfect co-operation, items of advice, support as well as help with bringing the theory into a real life.

Certainly, there are many people that are not explicitly listed here from many reasons. Nevertheless, you stay in my thoughts and heart and I am very grateful for everything you have done for me.

And finally I express a greatest possible gratitude to my parents for their continuous support in anything I do.

Regarding the financial arrangements, this work was supported from the state budget of the Czech Republic, through the Ministry of industry and commerce, in the scope of grant "5.1 SPK01/024 – EN-ERGOKLASTR", in the scope of grant No. FR-TI1/517, "Control Systems for Optimization of Energy Consumption in Low-Energy and Passive Houses", in the scope of grant No. 2A-1TP1/084, "Integration of building systems, research and application of intelligent algorithms with influence on energy consumption of buildings and living houses" and finally through grant CZ.1.05/2.1.00/03.0091 – University Center for Energy Efficient Buildings (UCEEB).

CONTENTS

1	AIMS OF THE DOCTORAL THESIS	1
2	MOTIVATION AND CONTRIBUTIONS OF THE WORK	3
3	PAPERS	7
3.1	Model Predictive Control of a Building Heating System: The First Experience	7
3.2	Modeling crucial for building predictive control	17
3.3	Selection of the Most Appropriate Model for Predictive Control	53
4	RESULTS	65
5	CONCLUSIONS AND POTENTIAL DEVELOPMENT	67
5.1	Future Development	68
6	FULLFILMENT OF THE OBJECTIVES	71
	BIBLIOGRAPHY	73

ACRONYMS

MIMO	Multiple-Input Multiple-Output
SID	System Identification
4 SID	Subspace State Space System Identification
MPC	Model Predictive Control
MRI	Model Predictive Control Relevant Identification
PLS	Partial Least Squares
SISO	Single-Input Single-Output
PI	Prior Information
HVAC	Heating, Ventilation, and Air Conditioning
PID	Proportional-Integral-Derivative
BEMS	Building Energy Management System
BCVTB	Building Controls Virtual Testbed
RC	Resistance-Capacitance
CTU	Czech Technical University in Prague
EP	EnergyPlus
SW	Software
BAS	Building Automation System
IRA	Integrated Room Automation
PMV	Predicted Mean Vote
LTI	Linear Time Invariant
LRT	Likelihood Ratio Test
WoS	Web of Science

DEPB The Directive on the Energy Performance of Buildings

DSPM Deterministic Semi-Physical Modeling

PSPM Stochastic Semi-Physical Modeling

AIMS OF THE DOCTORAL THESIS

As was mentioned above, the MPC used for building's climate control is a novel approach with identification and modeling being the most tedious, cumbersome and time-demanding part of the whole framework. Therefore, the goals of this thesis were set as follows:

1. *To perform a survey of the currently available approaches.* There is a huge number of identification and modeling approaches developed over the years, but not all of them are suitable for predictive control and even lesser are proper to use for buildings.
2. *To select and analyse the suitable approaches.* Apart from the survey, the thesis will select only those methods that are suitable for predictive control applied to buildings with analysing and assessing their pros and cons.
3. *To find a solution to the specific problems of building modeling techniques.* The statistically-based identification approaches are able to treat MIMO systems, however, they need the data of a certain quality, e.g. excitation of the corresponding order, low or no data corruption. The thesis should address the issue of statistical identification for buildings with respect to the data quality.
4. *To develop the model selection and validation methodology.* In real applications and buildings specifically, there is very often an enormous quantity of the system inputs, (measurable) disturbances and system states. Not all of them contribute with the same information and many of them are completely useless for identification process. The methodology that treats the problem of input/state selection would greatly reduced identification complexity.

MOTIVATION AND CONTRIBUTIONS OF THE WORK

There are several reasons, why the building climate control has been drawing much attention lately both in academic and industrial worlds. The buildings account for 20–40 % of the total final energy consumption and in developed countries the per year increases are 0.5–5 % [Perez-Lombard et al., 2008]. Moreover, the buildings produce 33 % of global CO₂ emissions. On the other hand, they have very large potential of both primary energy and CO₂ reduction [Metz, 2007]. In addition, as pointed out by [Ekins and Lees, 2008], currently available energy efficiency measures could save about 30 % of the current energy consumption. This can be done by refurbishment (e.g. installation of building integrated photovoltaic system for preheating of the fresh air [Lodi et al., 2012]), using the energy certificates, changing thus the user behavior (actually, the Energy Performance of Buildings Directive of European Commission requires the residential buildings to have Energy Performance Certificate when they are sold, rented or reconstructed) [Bull et al., 2012] or optimization techniques applied to Building Automation System (BAS).

The potential for saving the energy was first time fully recognized within the Opticontrol Project [ETH, 2007] with main objectives to [Gyalistras and Gwerder, 2010] i) develop the software, models and data sets for the integrated optimization of buildings and building systems, ii) to improve rule-based Integrated Room Automation (IRA) control strategies, iii) to introduce a novel model predictive control algorithms tailored to buildings, iv) to propose new algorithms for delivering optimally precise hourly temperature and radiation forecasts at a building's location, and v) to perform comparative analysis of energy saving potentials for IRA.

The project was aimed at the IRA dealing with the automated control of blinds, electric lighting, heating, cooling, and ventilation of an individual building zone [ETH, 2007]. The whole project was intended as a large simulation case study with developing the general rules for the above-mentioned objectives.

Soon thereafter a project with very similar motivation but completely different means and objective was launched in Prague. As of 2009 and 2010, first experiments on the **real** building were performed and a potential of the MPC for control of BAS was summarized in [Prívará et al., 2011]. The paper summarizes state-of-the-art approaches to the heating (such as Proportional-Integral-Derivative (PID) controllers) in Section 2 and discusses the potential of the MPC in Sec-

tion 3. Finally, the last Section provides reader with the results from the real operation of the building of the Czech Technical University in Prague (CTU). There can be seen a huge savings potential (approximately 30 %), which stimulates further research.

The MPC opens up the possibilities of exploiting the thermal storage capacities of the buildings making use of a prediction of the future disturbances (internal gains due to presence of people and equipment, weather) given some specific requirements such as control ranges instead of single value set-points for controlled variables, known (in-advance) or at least estimated ranges for controlled variables, disturbances, control costs, etc. The analysis of savings potential by employing predictive strategies were addressed in e.g. [Gyalistras et al. \[2010\]](#); [Oldewurtel et al. \[2010a\]](#). The other applications of the MPC within the buildings were energy peak reductions [Rijksen et al. \[2009\]](#); [Katipamula et al. \[2010\]](#); [Oldewurtel et al. \[2010b\]](#), discontinuously occupied buildings [Hazyuk and Ghiaus \[2010\]](#), pre-cooling [Ma et al. \[2010\]](#), time-varying electrical energy price [Ma et al. \[2009\]](#) and others. One of the most up-to-day developments in the field of MPC applications is a change of the concept in formulation of the optimization problem. Instead of classic minimization of the energy consumption, or economic cost, the new approach optimizing the subjective feelings of the users was introduced. This concept, entitled Predicted Mean Vote (PMV), is treated in detail by [\[Cigler et al., 2012\]](#). Finally, the thorough review of the MPC applications and their possible modifications was provided by [\[Široký et al., 2011\]](#).

Even though there have been developed some techniques which enable implementation of MPC directly from the input-output data (see [Stenman \[2002\]](#); [Huang and Kadali \[2008\]](#); [Rossiter and Kouvaritakis \[2001\]](#)), the dynamic model still plays the crucial role in a MPC approach.

Most of the industrial applications (as well as buildings) are MIMO systems for which there exist a suitable family of methods, namely 4SID. 4SID methods originally emerged as a conjunction of linear algebra, geometry and system theory and compared to the classic identification methods [Ljung \[1999\]](#), they provide the user with several advantages such as numerical robustness, natural extension to MIMO systems, etc. There are, however, also some drawbacks, e.g. lack of satisfactory number of data samples, proper order of excitation or strong noise contamination can lead to poor identification results [\[Ljung, 1999; Willems et al., 2005\]](#). Some problems coupled to these methods, such as identification of stable, positive, real models, etc., using regularization can be found in [Van Gestel et al. \[2000\]](#); [Goethals et al. \[2003\]](#) or formulated as a constrained optimization, as in [Lacy and Bernstein \[2003\]](#). The black-box identification, such as 4SID, relies only on experimental data, that is, they may result in biased models [\[Trnka and Havlena, 2009\]](#), or fail in giving a proper model (this problem is

addressed by Gevers et al. [2005]; Rojas et al. [2008]). Prior information can significantly improve the identification results, however, the current algorithms are not able to provide satisfactory results for the MIMO systems. Previous works, such as Bai and Sastry [1986], count with a Single-Input Single-Output (SISO) system only. The detailed review of the approaches of the incorporation of the Prior Information (PI) was given by Section 1 of [Privara et al., 2012]. Section 2 proposes a new way of solving the problem of incorporation of PI into the 4SID algorithm, namely into matrices B and D. The proposed solution enables incorporation of known static gain and zero matrix D.

Unfortunately, this solution is very limited as we do not always know the static gain, moreover, that is usually not the only problem. When creating a building model, two basic paradigms to derive a total model of building dynamics are at hand. The first one originated in Heating, Ventilation, and Air Conditioning (HVAC) engineering and building automation communities, a “traditional” approach, which uses knowledge of the structure and physical and material properties of a building. A detailed building model is then assembled from simple subsystems mutually physically interacting, making use of computer aided modeling tools, or Building Energy Management System (BEMS), e.g. Trnsys Thermal Energy System Specialists [2012], EnergyPlus of Energy [2011], ESP-r ESP [2011], etc. Their objective is to simulate the behavior of the building, however, they do not provide an explicit model¹, thus can be hardly used for control oriented modeling. An alternative is to use statistically-based, i.e. data-driven approaches, resulting in a model in an explicit form. The concept of interconnection of these two methods, i.e. computer aided modeling tools and subsequent statistical identification using Building Controls Virtual Testbed (BCVTB) are introduced in Section 3 of [Privara et al., 2013a] and the application to the real data gathered from the large office building in Munich is described in the Section 4.

It is a well-known fact, that the modeling and System Identification (SID) are the most difficult and time-consuming part of the automation process as such Zhu [2001], and particularly, employing predictive technologies. The basic conditions, that each model intended for MPC usage should satisfy, are the reasonable simplicity, well estimated system dynamics and steady-state properties as well as satisfying prediction properties (fitting on multi-step prediction). These requirements do not need to be of the same quality at the whole frequency range, rather they should comply with the quality requirements for the control-relevant frequency range (see e.g. Hjalmarsson [2009]; Gopaluni et al. [2004]; Shook et al. [2002]). As the MPC optimizes over some time horizon, the model used for

¹ Note that in this context, we call a model explicit if there are mathematical formulas describing a state evolution, i.e. a set of differential or difference equations is available. Otherwise the model is called implicit.

optimization should primarily be a good predictor over the same horizon. Hence, we are not specifically interested in its performance on the single-step ahead predictions, rather on the control horizon. The family of methods dealing with multi-step ahead predictions are called [MRI](#). There is, however, often a problem of contamination with noise or too much “explanatory variables” with low or no contribution to solution of the regression problem and therefore the Partial Least Squares ([PLS](#)) were taken and combined with [MRI](#) into a new combined algorithm ([MRI+PLS](#)). The problem is addressed in Section 3 of [[Prívará et al., 2013b](#)]. The paper presents comparison of the methods frequently used in building modeling such as Stochastic Semi-Physical Modeling ([PSPM](#)), Deterministic Semi-Physical Modeling ([DSPM](#)) (often called Resistance-Capacitance ([RC](#)) modeling) and algorithms based on multistep error minimization. The results presented in Section 4 of this paper clearly demonstrate, that with proper choice of the number of components, one can obtain superior results in comparison to [MRI](#) only.

As the various identification or modeling techniques give rise to a large number of different models, the problem which must be often solved is to decide how to choose a suitable model for the control purposes. The problem is not only the identification of a model which is in accordance to the physical reality and matches the data measured on the process, but also a choice of its parameters. The final set of parameters used within the model should be as small as possible, yet containing a sufficient level of information extracted from the data.

In case of models with given sets of inputs and outputs and with open set of states (parameters), a natural question arises: what is the minimum possible set of states which contains (statistically) the same information as a set one element larger. Or rephrased, what (statistically significant) information is gained from the addition of a state. There are several tests which solve this issue [Gourieroux et al. \[1982\]](#); [Dickey and Fuller \[1981\]](#).

A different problem is to select an appropriate model when the sets of inputs and outputs are not fixed, i.e. these sets are to be chosen during the identification procedure. Such a task of model selection becomes more difficult than in the previous case. The interpretation of the estimation problem shifts as well. The objective is still the same - to select the best model for control, however, apart from the minimum number of states, the number of inputs and outputs is of interest as well. This problem was addressed by Section 3 of [[Prívará et al., 2012](#)], where not only the methodology for selection of the inputs/states was presented, but also the statistical validation of the residuals making use of a variety of statistical tests, e.g. Likelihood Ratio Test ([LRT](#)).

PAPERS

Each paper with original formatting follows always on the next page after the short comment. Only those paper relevant to the topic of the dissertation thesis and with author's share more than 30% are provided here. The rest of the author's papers are listed in the author's publication list.

Samuel Prívvara is author or co-author of 7 Web of Science (WoS) papers and an Inderscience paper. His h-index is 3 in WoS with 24 WoS and 35 Scopus citations (auto-citations excluded).

3.1 MODEL PREDICTIVE CONTROL OF A BUILDING HEATING SYSTEM: THE FIRST EXPERIENCE

Eenergy and Buildings paper entitled *Model Predictive Control of a Building Heating System: The First Experience* is treating the first real-life application of the MPC on the CTU building in Prague. Apart from the number of analyses and results from the first operational heating season, the paper discusses the previous ways of HVAC control.

The share of the author on the result according to VVVS is 40%.

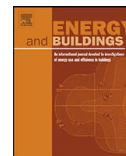

Model predictive control of a building heating system: The first experience

Samuel Prívvara^{a,*}, Jan Široký^b, Lukáš Ferkl^a, Jiří Cigler^a

^a Department of Control Engineering, Faculty of Electrical Engineering, Czech Technical University in Prague, Technická 2, 166 27 Praha 6, Czech Republic

^b Department of Cybernetics, Faculty of Applied Sciences, University of West Bohemia in Pilsen, Czech Republic

ARTICLE INFO

Article history:

Received 16 February 2010

Received in revised form 12 October 2010

Accepted 18 October 2010

Keywords:

Optimal control

Subspace identification

Model predictive control

Costs effectiveness

ABSTRACT

This paper presents model predictive controller (MPC) applied to the temperature control of real building. Conventional control strategies of a building heating system such as weather-compensated control cannot make use of the energy supplied to a building (e.g. solar gain in case of sunny day). Moreover dropout of outside temperature can lead to underheating of a building. Presented predictive controller uses both weather forecast and thermal model of a building to inside temperature control. By this, it can utilize thermal capacity of a building and minimize energy consumption. It can also maintain inside temperature at desired level independent of outside weather conditions. Nevertheless, proper identification of the building model is crucial. The models of multiple input multiple output systems (MIMO) can be identified by means of subspace methods. Oftentimes, the measured data used for identification are not satisfactory and need special treatment. During the 2009/2010 heating season, the controller was tested on a large university building and achieved savings of 17–24% compared to the present controller.

© 2010 Elsevier B.V. All rights reserved.

1. Introduction

According to the U.S. Energy Information Administration, in 2005, buildings accounted for 39% of total energy usage, 12% of the total water consumption, 68% of total electricity consumption, and 38% of the carbon dioxide emissions in the U.S.A. [1]. Although the energy efficiency of systems and components for heating, ventilating, and air conditioning (HVAC) has improved considerably over recent years, there is still potential for substantial improvements. This article deals with an advanced control technique, that can provide significant energy savings in comparison with conventional, non-predictive techniques.

Widely used control strategy of water heating systems is the weather-compensated control. This feedforward control can lead to poor energy management or reduced thermal comfort even if properly set up, because it utilizes current outside temperatures only. Weather conditions, however, can change dramatically in few hours; and due to the heat accumulation in large buildings, it can lead to underheating or overheating of the building easily.

During recent years, significant advances have been done for the HVAC control systems [2–6]. For instance, continuous adaptation of control parameters, optimal start–stop algorithms, optimization of energy loads shifting [7], or inclusion of free heat gains in the control algorithm are particular improvements of the build-

ing heating system [8]. Some new concepts have been verified by simulations [9,10], nevertheless they are still waiting for real operations. The model predictive control, [11–15] (MPC) presented in this article introduces a different approach to the heating system control design. As the outside temperature is one of the most influential quantity for the building heating system, weather forecast is employed in the predictive controller. It enables to predict inside temperature trends according to the selected control strategy. The aims of the control can be expressed in natural form as thermal comfort and economy trade off. Unfortunately, this concept has some drawbacks, such as extensive computational requirements or necessity of a mathematical model of the physical system (building in this case).

All these issues are discussed in detail in following sections, which are organized as follows. Section 2 compares the current control techniques with MPC. Section 3 introduces model predictive control concept more in detail and explains the mathematical background of this technique. This section also addresses new modified zone model predictive controller. Problem of the model identification is discussed as well. Application results are summarized in Section 4. Remarks to future development are outlined in Section 5. The last section concludes the work.

List of abbreviations used throughout the article is mentioned in Table 1.

2. Current heating control strategies

Let us briefly compare the major state-of-the-art heating control techniques – on–off room temperature control, weather-

* Corresponding author. Tel.: +420 776 697 672.

E-mail addresses: samuel.privara@fel.cvut.cz (S. Prívvara), jan.siroky@rcwaeu.eu (J. Široký), lukas.ferkl@fel.cvut.cz (L. Ferkl), jiri.cigler@fel.cvut.cz (J. Cigler).

Table 1
Notation.

Abbrev.	Meaning
ARX	Auto-regressive model with external inputs
ARMAX	Auto-regressive, moving average model with external inputs
CTU	Czech Technical University in Prague
HVAC	Heating, ventilation and air-conditioning systems
MIMO	Multiple-input, multiple-output systems
MPC	Model predictive control
OE	Output error model
PID	Proportional – integrative – derivative controller
SISO	Single-input, single-output systems
WC	Weather-compensated control

compensated control, and PID [8] control – with the proposed application of MPC.

The *on-off room temperature control* is the simplest type of control; the heating devices in a room are switched on and off (device state S) according to some room temperature error ($e_t = t_{\text{required}} - t_{\text{room}}$) threshold, usually implemented as a suitable hysteresis curve $f_{\text{on-off}}$:

$$S = f_{\text{on-off}}(e_t) \quad (1)$$

This is a very simple feedback control, which does not contain any information about the dynamics of the building. The main advantage is its simplicity.

On the contrary, the *weather-compensated control* is a feedforward control, which also does not contain any information about the building dynamics. The temperature of the heating medium, such as water (t_{water}), is set according to the outside temperature t_{outside} by means of predetermined heating curves f_{w-c} , that is

$$t_{\text{water}} = f_{w-c}(t_{\text{outside}}) \quad (2)$$

In spite of the lack of dynamics in the control, this is a long used and proven control strategy; its advantage is its robustness and simple tuning.

PID control is one of the most favorite strategies of control engineers [16,17]. It is a feedback control with some information about the system dynamics, that is, the heating water temperature t_{water} is determined according to the room temperature error e_t and “some” history:

$$t_{\text{water}} = f_{\text{PID}}(e_t, \text{history}) \quad (3)$$

PID controllers are robust and allow accurate tuning, but they cannot reflect the outside temperature effects. This is the reason why PIDs in HVAC control are not as common as in other control applications.

Even though all the above controllers are easy to tune for single-input, single-output (SISO) systems, their tuning for multiple-input multiple-output (MIMO, sometimes called multidimensional) systems becomes very difficult or even impossible in practice. The PID control can be applied to MIMO systems only in very rare occasions, in case of specially structured (input–output decoupled) systems.

We would therefore appreciate some control strategy, which would have a feedback (i.e. the room temperature error e_t is used), use as much information as possible (the outside temperature t_{outside} , the weather forecast $t_{\text{predicted}}$, and others x) and include some system dynamics (“history”) as well. This can be formalized – in the spirit of the above Eqs. (1)–(3) – as

$$t_{\text{water}} = f_{\text{MPC}}(e_t, t_{\text{outside}}, t_{\text{predicted}}, x, \text{history}) \quad (4)$$

These requirements are satisfied by a so-called model (based) predictive controller (MPC), which is specially suitable for systems with multiple inputs and multiple outputs, which is very typical for heating systems. Its main drawbacks are high demands



Fig. 1. The building of the Czech Technical University in Prague that was used for MPC application.

for computational resources and non-trivial mathematical background, especially in the “Model” part of the controller.

3. Model predictive control

3.1. State of the art

Model (based) predictive control (MPC) is a method of advanced control originated in late seventies and early eighties in the process industries (oil refineries, chemical plants, etc.) [11]. The MPC is not a single strategy, but a vast class of control methods with the model of the process explicitly expressed trying to obtain control signal by minimizing objective function subject to (in general) some constraints [18]. The minimization is performed in an iterative manner on some finite optimization horizon to acquire N step ahead prediction of control signal that leads to minimum criterion subject to all constraints. This, however, carries lots of drawbacks such as no feedback, no robustness, and no stability guarantee. Many of these drawbacks can be overcome by applying so-called receding horizon, i.e. at each iteration only the first step of the control strategy is implemented and the control signal is calculated again, thus, in fact, the prediction horizon keeps being shifted forward. Stability of the constrained receding horizon has been discussed in Refs. [13,14], or yet another approach using robust control design approach [15].

There were several attempts made to utilize predictive control concept in HVAC in the last decade [19,9,20,21,10]. Complex view into area of optimal building control gives the project OptiControl.¹ Besides its own results, it also provides a wide range of references to the related articles. Another project worth to mention is the predictive networked building control that deals with predictive control of the thermal energy storage on the campus of the UC-Berkeley.² Most of the articles devoted to the HVAC predictive control conclude results just by numerical simulations. On the contrary, this article describes MPC being tested on the real eight-floor building (see Fig. 1).

3.2. Principles

We will now briefly describe the basic ideas lying behind the MPC. To be more illustrative, we will take the course of the MPC implementation in our own project; even though the experienced practitioners in heating control are rather conservative in their field, they can accept new method, such as MPC, if performed in small, consecutive steps, which helps them to get acquainted with its principles.

¹ <http://www.opticontrol.ethz.ch>.

² <http://sites.google.com/site/mpclaboratory/research/predictive-networked-building-control-1>.

Having a well working control, such as weather-compensated control of a building, it is often unwise to change it to something novel, but unproven. However, it can be very advantageous to provide a “tool” that would enhance the possibilities of the existing system. A mathematical model can be such a “tool”, allowing the system operators to predict the behavior of the building. If the model is accurate enough (e.g. as a one-day predictor), another feature can be added—the operator can experiment with the model and try some “what if” scenarios. The next step is obviously implementation of an algorithm that proposes the best scenarios; it is still a “tool”, the model and algorithm are not involved in the control loop. That would be the last step – after the operator begins to trust the algorithm, he begins to ask for the closer of the control loop incorporating what we call model predictive control.

To be more precise, the first step is to find a dynamic model P

$$y = P(u, t) \tag{5}$$

where y is the output, u is the input (both can be vectors) and t is time. Inputs u may be entered by the operator in the beginning, such that he can see the expected behavior of the system, as seen on outputs y . The next step is finding the optimal inputs u automatically. This can be achieved by introducing an optimality criterion $J(y, u, t)$, wherein the control demands are described in the language of mathematics. Substituting from (5), the optimal control inputs can be found by computing

$$u_{\text{optimal}} = \min_u J(P(u, t), u, t) \tag{6}$$

subject to “some” constraints. This very basic idea will now be discussed more in detail.

3.3. Model identification

One of the crucial contributors to the quality of the control is a well identified model which will be later on used for control in MPC algorithm. There are several completely different approaches to system identification (see e.g. [22,23]). Some of them use knowledge of system physics, while others exploit statistical data, such as grey-box [24,25] (some prior information such as system structure is known in advance) or black-box identification. Grey box methods using models such as ARX, ARMAX, OE and others are well established among the practitioners as well as theoreticians. There is, however, a significant problem, when multiple input multiple output (MIMO) systems are considered. The standard input–output identification methods are not capable of dealing with such a model, thus one has to either reformulate the problem to several single-output cases, or to use state-space identification methods, such as subspace methods. The first approach, including computer modeling of the building, as well as comparison of ARMAX model and subspace methods, was briefly described in [26].

The main difference between classical and subspace identification can be seen in Fig. 2 (see Ref. [27]). Given the sequence of input and output data, $u(k)$ and $y(k)$, respectively, do:

- **Classical approach.** Find system matrices, then estimate the system states, which often leads to high order models that have to be reduced thereafter.
- **Subspace approach.** Use orthogonal and oblique projections to find Kalman state sequence, then obtain the system matrices using least squares method. Here we introduce the latter—subspace identification methods.

The objective of the subspace algorithm is to find a linear, time invariant, discrete time model in an innovative form:

$$\begin{aligned} x(k+1) &= Ax(k) + Bu(k) + Ke(k) \\ y(k) &= Cx(k) + Du(k) + e(k), \end{aligned} \tag{7}$$

based on given measurements of the input $u(k) \in \mathbb{R}^m$ and the output $y(k) \in \mathbb{R}^l$ generated by an unknown stochastic system of order n , which is equivalent to the well-known stochastic model:

$$\begin{aligned} x(k+1) &= Ax(k) + Bu(k) + w(k) \\ y(k) &= Cx(k) + Du(k) + v(k), \end{aligned} \tag{8}$$

with covariance matrices Q , S and R of process and measurement noise sequences as follows:

$$\text{cov}(w, v) = E \left(\begin{bmatrix} w(p) \\ v(p) \end{bmatrix} \begin{bmatrix} w^T(q) & v^T(q) \end{bmatrix} \right) = \begin{bmatrix} Q & S \\ S^T & R \end{bmatrix} \delta_{pq} \geq 0, \tag{9}$$

and with A , B , C , and D denoting system matrices and K and e in (7) is Kalman gain – derived from the Algebraic Riccati Equation (ARE) [28], and white noise sequence, respectively. Loosely speaking, the objective of the algorithm is to determine the system order n and to find the matrices A , B , C , D and K .

3.3.1. Data matrices for subspace algorithm

The following matrices are necessary to form for subspace algorithm. Notation was adapted as in Ref. [27]. Upper index d denotes deterministic subsystem, while the upper index s denotes stochastic subsystem. Two kinds of matrices are used for subspace algorithm, data and system related matrices.

- **Data matrices.** Input and output block Hankel matrix are formed from input and output data as follows:

$$U_{0|2i-1} = \begin{pmatrix} u_0 & u_1 & u_2 & \cdots & u_{j-1} \\ u_1 & u_2 & u_3 & \cdots & u_j \\ \vdots & \vdots & \vdots & \ddots & \vdots \\ u_{i-1} & u_i & u_{i+1} & \cdots & u_{i+j-2} \\ u_i & u_{i+1} & u_{i+2} & \cdots & u_{i+j-1} \\ u_{i+1} & u_{i+2} & u_{i+3} & \cdots & u_{i+j} \\ \vdots & \vdots & \vdots & \ddots & \vdots \\ u_{2i-1} & u_{2i} & u_{2i+1} & \cdots & u_{2i+j-2} \end{pmatrix} \quad Y_{0|2i-1} = \begin{pmatrix} y_0 & y_1 & y_2 & \cdots & y_{j-1} \\ y_1 & y_2 & y_3 & \cdots & y_j \\ \vdots & \vdots & \vdots & \ddots & \vdots \\ y_{i-1} & y_i & y_{i+1} & \cdots & y_{i+j-2} \\ y_i & y_{i+1} & y_{i+2} & \cdots & y_{i+j-1} \\ y_{i+1} & y_{i+2} & y_{i+3} & \cdots & y_{i+j} \\ \vdots & \vdots & \vdots & \ddots & \vdots \\ y_{2i-1} & y_{2i} & y_{2i+1} & \cdots & y_{2i+j-2} \end{pmatrix}, \tag{10}$$

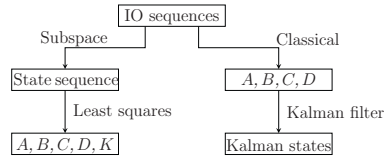

Fig. 2. Comparison between classical and subspace identification methods.

which can be written in shorten form as follows:

$$\begin{pmatrix} U_{0i-1} \\ U_{i2i-1} \end{pmatrix} = \begin{pmatrix} U_p \\ U_f \end{pmatrix} \quad (11)$$

$$\begin{pmatrix} Y_{0i-1} \\ Y_{i2i-1} \end{pmatrix} = \begin{pmatrix} Y_p \\ Y_f \end{pmatrix},$$

where matrices U_p and U_f represent past and future inputs, respectively. Outputs $y(k)$ and noise $e(k)$ related matrices can be formed in similar manner. Grouped data matrix consisting of past input and past output data is formed as follows:

$$W_p = W_{0i-1} = \begin{pmatrix} U_{0i-1} \\ Y_{0i-1} \end{pmatrix}.$$

- **System related matrices.** Extended ($i > n$) observability (Γ_i) and reversed extended controllability (Δ_i) matrices for deterministic and stochastic subsystems, respectively are defined as follows:

$$\Gamma_i = \begin{pmatrix} C \\ CA \\ \vdots \\ CA^{i-1} \end{pmatrix} \quad (12)$$

$$\Delta_i^d = (A^{i-1}B \ A^{i-2}B \ \dots \ AB \ B) \quad (13)$$

$$\Delta_i^s = (A^{i-1}K \ A^{i-2}K \ \dots \ AK \ K) \quad (14)$$

Algorithm also uses lower block triangular Toeplitz matrix for deterministic and stochastic subsystem, respectively:

$$H_i^d = \begin{pmatrix} D & 0 & 0 & \dots & 0 \\ CB & D & 0 & \dots & 0 \\ CAB & CB & D & \dots & 0 \\ \vdots & \vdots & \vdots & \ddots & \vdots \\ CA^{i-2}B & CA^{i-3}B & CA^{i-4}B & \dots & D \end{pmatrix}$$

$$H_i^s = \begin{pmatrix} I & 0 & 0 & \dots & 0 \\ CK & I & 0 & \dots & 0 \\ CAK & CK & I & \dots & 0 \\ \vdots & \vdots & \vdots & \ddots & \vdots \\ CA^{i-2}K & CA^{i-3}K & CA^{i-4}K & \dots & I \end{pmatrix}. \quad (15)$$

3.3.2. Subspace algorithm

The entry point to the algorithm are input–output equations as follows:

$$\begin{aligned} Y_p &= \Gamma_i X_p + H_i^d U_p + H_i^s E_p \\ Y_f &= \Gamma_i X_f + H_i^d U_f + H_i^s E_f \\ X_f &= A^i X_p + \Delta_i^d U_p + \Delta_i^s E_p. \end{aligned} \quad (16)$$

Oblique projection as described in Refs. [29,27] is the main tool used in subspace methods is defined as follows:

$$O_i = Y_f / W_p. \quad (17)$$

The order of the system can be determined from analysis of singular values obtained using singular value decomposition (SVD) of $W_1 O_i W_2$, where W_i are weighting matrices of particular size and determine resulting state space basis. It has been shown [27], that $O_i = \Gamma_i \tilde{X}_i$, where \tilde{X}_i is Kalman filter state sequence. This factorization also yields extended observability matrix Γ_i and Kalman filter states \tilde{X}_i .

Algorithm continues from either Γ_i or \tilde{X}_i in a slightly different manner depending on particular subspace identification algorithm, however, both ways lead to a computation of system matrices A and C using least squares method.

Computation of system matrices B and D follows subject to matrices A and C computed in previous step. Different approaches for matrices determination are addressed in detail in Ref. [27].

The algorithm concludes with computation of Kalman gain matrix K in a standard way using state and output noise covariance matrices (9) which are computed from residuals of the previous computations.

The model structure used in MPC is the state-space model (7) identified by subspace identification (described in Section 3.3) from measured data. The application of the model will become apparent later in this section.

3.4. Predictive controller

3.4.1. MPC strategy

The MPC strategy comprises two basic steps:

- The future outputs are predicted in an open-loop manner using the model provided information about past inputs, outputs and future signals, which are to be calculated. The future control signals are calculated by optimizing the objective function, i.e. chosen criterion, which is usually in the form of quadratic function. The criterion constituents can be as follows:
 - errors between the predicted signal and the reference trajectory $y_r(k)$;
 - control effort;
 - rate of change in control signals.
- The first component of the optimal control sequence $u(k)$ is sent to the system, whilst the rest of the sequence is disposed. At the next time instant, new output $y(k+1)$ is measured and the control sequence is recalculated, first component $u(k+1)$ is applied to the system and the rest is disposed. This principle is repeated *ad infinitum* (receding horizon).

The reference trajectory $y_r(k)$, room temperature in our case, is known prior, as a schedule. The major advantage of MPC is the ability of computing the outputs $y(k)$ and corresponding input signals $u(k)$ in advance, that is, it is possible to avoid sudden changes in control signal and undesired effects of delays in system response.

Standard formulation of criterion for MPC is as follows:

$$J = \sum_{k=0}^{N-1} q(k)(y(k) - y_r(k))^2 + r(k)u(k)^2, \quad (18)$$

where $q(k)$ is weight for difference between system output $y(k)$ and reference $y_r(k)$ at time instant k , while $r(k)$ is the weight of the displacement of control signal $u(k)$. If the future desired output value is known in advance, then this criterion leads to such an optimal system input, which minimizes weighted square of $y(k) - y_r(k)$. By

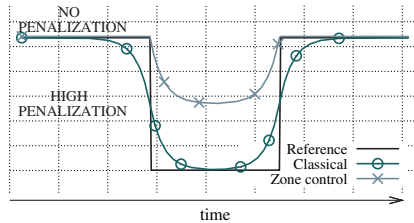

Fig. 3. Comparison between classical and zone predictive strategy. Weighting of entirely negative errors makes predictive controller to follow accurately the upper part of reference trajectory. When step down of desired value occurs, the system output drops to the reference value with a minimum control effort.

this, the area delimited by the system output below desired value is same as the area above it. This is depicted in Fig. 3 by line marked with circles. Such a behavior is satisfactory for most of the common control problems but not for temperature control of a building. The aim of the control is to adhere the upper desired value from its beginning to its end. Resulting behavior of the output is delineated in Fig. 3 by line with crosses.

This unusual problem can be solved by several approaches:

- The intuitive method is to use dynamic weights $q(k)$ and $r(k)$ at time, i.e. to make them time-dependant. These weights then depend on the shape of the reference trajectory – if there is a step-up/down on a prediction horizon, then weight $q(k)$ is set to be greater than $r(k)$ for k when the reference trajectory is on upper level, whilst $q(k) < r(k)$ for the rest of k on prediction horizon. This simple procedure ends if there exists more reference trajectory levels than two (but in this case is the best way how to solve such a problem).
- The second approach is as follows: In the minimization of the criterion (18) the reference trajectory y_r can be substituted with “artificial” reference w , which can be some approximation from the actual output y to real reference y_r . This can be done using following convex combination [30]:

$$w(k) = y(k) \tag{19}$$

$$w(k+i) = \alpha w(k+i-1) + (1-\alpha)y_r(k+i),$$

where $i=1 \dots N$ and $\alpha \in (0;1)$ is a parameter, that determines the smoothness (and speed) of the approaching of the real output to the real reference. (19) can be also restated as follows:

$$w(k) = y(k) \tag{20}$$

$$w(k+i) = \alpha r(k+i) - \alpha^i(y(k) - y_r(k)).$$

Making use of artificial reference may be very helpful in the case of number of “steps” in reference trajectory with need of its precise tracking by the actual output.

- Completely different way is to reformulate the part of criterion (18), which refer to the desired value error. If $y(k) < y_r(k)$ then weight the square of this difference using $q(k)$, otherwise the error is not weighted. This can be treaded by using the concept of zone control (also called funnel MPC) [18] where the reference error is not weighted in a specified interval while the weighting out is made in a common way. The lower bound of the interval is in our case desired value, whilst the upper bound is not specified due to the fact, that the building naturally tends to underheat providing the weighted output. Such a method can be used for tracking of reference trajectory with arbitrary number of levels.

The last approach will be discussed in detail.

3.4.2. MPC problem formulation

For a given linear, time invariant, discrete-time deterministic model

$$x(k+1) = Ax(k) + Bu(k) \tag{21}$$

$$y(k) = Cx(k) + Du(k)$$

find the optimal control sequence on the horizon of prediction (length N) by minimizing the objective function

$$J = \sum_{k=0}^{N-1} q(k)(y(k) - z(k))^2 + r(k)u(k)^2, \tag{22}$$

subject to

$$u_{\min} \leq u(k) \leq u_{\max} \tag{23}$$

$$y_r(k) \leq z(k)$$

$$\Delta_{\max} \geq |u(k) - u(k-1)|$$

where constraints u_{\min}, u_{\max} are the minimum and maximum values of the control signal, $y_r(k)$ is desired value, thus lower bound for $z(k)$ and Δ_{\max} is a maximum rate of change of the control signal.

The objective function J (in (22)) can be rewritten into a matrix form (denoted without specification of a time instant)

$$J = (y - z)^T Q (y - z) + u^T R u, \tag{24}$$

where Q and R are weighting matrices of output error and control effort, respectively. The trajectory of the output is given as:

$$\begin{bmatrix} y(0) \\ y(1) \\ \vdots \\ y(N-1) \end{bmatrix} = \begin{bmatrix} C \\ CA \\ \vdots \\ CA^{N-1} \end{bmatrix} x(0) + \begin{bmatrix} D & & & \\ CB & D & & \\ \vdots & & \ddots & \\ CA^{N-2}B & \dots & CB & D \end{bmatrix} \begin{bmatrix} u(0) \\ u(1) \\ \vdots \\ u(N-1) \end{bmatrix}, \tag{25}$$

i.e.

$$y = \Gamma x(0) + Hu, \tag{26}$$

where Γ is extended observability matrix and H is a matrix of impulse responses. Let $\tilde{y} = \Gamma x(0)$, then using (26), we can rewrite (24) as follows:

$$J = (\tilde{y} + Hu - z)^T Q (\tilde{y} + Hu - z) + u^T R u. \tag{27}$$

Minimization of such an objective function is a nonlinear programming problem, which can be readily rewritten into quadratic programming problem

$$J = \begin{bmatrix} u^T & z^T \end{bmatrix} \begin{bmatrix} H^T Q H + R & -H^T Q \\ -Q H & Q \end{bmatrix} \begin{bmatrix} u \\ z \end{bmatrix} + 2 \begin{bmatrix} \tilde{y}^T Q H & -\tilde{y}^T Q \end{bmatrix} \begin{bmatrix} u \\ z \end{bmatrix} + \tilde{y}^T Q \tilde{y} \tag{28}$$

This yields the optimization problem $\min_{u,z} J$, which can be effectively solved using some of the computer algebra systems. The resulting problem has $(m+p) \cdot T$ variables which is a greater dimension compared to the classical one (described by criterion (18)) with $m \cdot T$ variables, where m and p are number of inputs and outputs respectively.

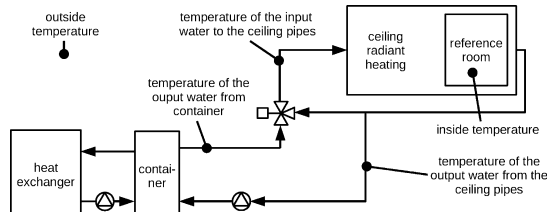

Fig. 4. Simplified scheme of the ceiling radiant heating system.

4. Application

The methods described in the previous sections were tested through December 2009 and January 2010 and the real run of control application using proposed control strategy started in February 2010 at the building of the Czech Technical University in Prague. As of February 2010 the whole building consisting of 7 control blocks is controlled by presented MPC algorithm. All algorithms were implemented in Scilab.³

4.1. Description of the building

The building of the Czech Technical University in Prague uses a “Crittall” type ceiling radiant heating and cooling system. The “Crittall” system, invented in 1927 by R.G. Crittall and J.L. Musgrave [31], was a favorite heating system in the Czech Republic during 1960s for large buildings. In this system, the heating (or cooling) beams are embedded into the concrete ceiling. The control of individual rooms is very complicated due to the technical state of the control elements in all rooms. The control is therefore carried out for one entire building block, i.e. the same control effort is applied to all rooms of the building block. There are two (out of seven control blocks) building blocks with the same construction and orientation. Therefore, this situation is ideal for comparison of different control strategies, as depicted in Fig. 5.

A simplified scheme of the ceiling radiant heating system is illustrated in Fig. 4. The source of heat is a vapor–liquid heat exchanger, which supplies the heating water to the water container. A mixing occurs here, and the water is supplied to the respective heating circuits. An accurate temperature control of the heating water for respective circuits is achieved by a three-port valve with a servo drive. The heating water is then supplied to the respective ceiling beams. There is one measurement point in a reference room for every circuit. The setpoint of the control valve is therefore the control variable for the ceiling radiant heating system in each circuit.

4.2. Description of the model

The ceiling radiant heating system was modeled by a discrete-time linear time invariant stochastic model. We can consider this model as a Kalman filter giving an estimate of $\hat{x}(k)$ and $\hat{y}(k)$. Outside temperature prediction and heating water temperature were used as the model inputs. Prediction of outside temperature is composed of two values T_{\max} and T_{\min} defining a confidence interval. The outputs of the model are estimates of inside temperature \hat{T}_{in} and of

return water⁴ \hat{T}_{rw} . This can be formalized according to (21) as

$$\begin{aligned} \hat{x}(k+1) &= A\hat{x}(k) + B \begin{bmatrix} T_{\min}(k) \\ T_{\max}(k) \\ T_{hw}(k) \end{bmatrix} + K(y(k) - C\hat{x}(k)) \\ \begin{bmatrix} \hat{T}_{in}(k) \\ \hat{T}_{rw}(k) \end{bmatrix} &= C\hat{x}(k) + D \begin{bmatrix} T_{\min}(k) \\ T_{\max}(k) \\ T_{hw}(k) \end{bmatrix}, \end{aligned} \quad (29)$$

where T_{hw} is temperature of the heating water and T_{in} denotes the inside temperature. System matrices A , B , C and D are to be identified using subspace methods as was described in Section 3.3.2. The state $\hat{x}(k)$ has no physical interpretation, when identified by means of the subspace identification. System order is determined by the identification algorithm. Modeling of the heating system of the CTU building is discussed in detail in Ref. [32].

4.3. Results

We have employed two methods of estimating the savings achieved on the building, based on comparison with a finely tuned weather-compensated controller (which also took weather forecast into account).

The first one was a cross-comparison of energy consumption in particular building blocks based on the difference between the heating and return water temperatures (this is directly proportional to the heat consumption provided that the pumps have a constant flow). In the period from mid-February to the end of the heating season (end of March), the overall savings reached 17–24%, depending on the particular building block.

The second method was based on comparison of calorimeter measurements for the entire building for MPC and said weather-compensated control. The measurements were normalized by outside temperatures and ambient temperature set-points to achieve reliable results. For said period of measurement, MPC achieved 29% savings according to this method.

It should be noted that the heating and return water temperature is being measured by standard industrial thermometers, which suffer from measurement errors, such as noise or offset. This introduces some uncertainty into the results. On the other hand, the calorimeters are installed by the heat provider, so we expect them to be well calibrated (or, at least, they do not measure less than the actual heat); heat payments are also based on the calorimeters. So in the terms of finances, the money savings of were also 29% (there is a flat rate on heat for the building).

Measurement of thermal comfort is always difficult and highly individual. As there are some 1500 employees and 8000 students in the building and there are always some people who complain about the ambient temperature, we decided to take the number of complains as the thermal comfort measure. To achieve objective results, the building occupants were not told about the new heating strategy. Under such conditions, the change in the number of complains was insignificant during the test period.

The results are depicted in Fig. 5. The upper part shows outside temperature, whilst the lower compares reference tracking for weather-compensated and predictive controllers. It can be seen, that the predictive controller heats in advance in order to perform optimal reference tracking, that is, inside comfort, and minimum energy consumption. Two last subfigures compare the efficiency

³ Open source scientific software package for numerical computations (<http://www.scilab.org/>).

⁴ It is crucial to model return water as an output because it gives a significant information about energy accumulated in the building, moreover it represents the interconnection between heating water and room temperature. Omitting the return water would lead to significant loss of information.

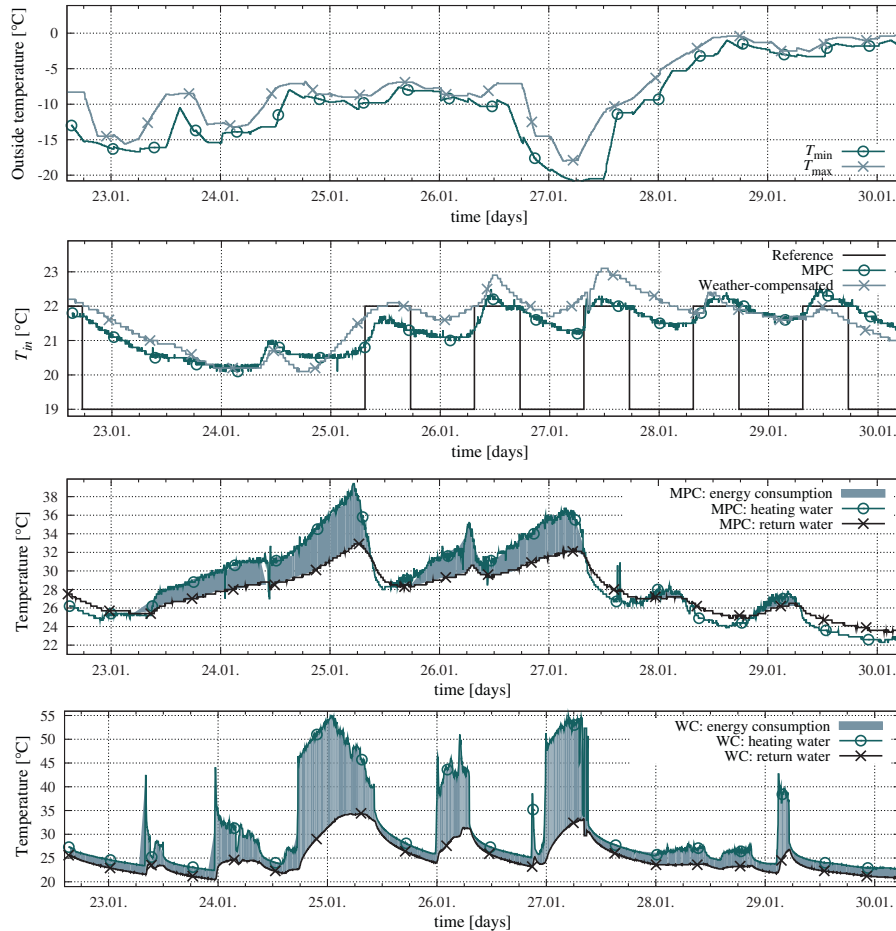

Fig. 5. Different control strategies: comparison of weather-compensated (WC) and predictive control (MPC) of heating water temperature and the room temperature controlled by MPC.

of control measured by energy consumption. The efficiency of the predictive control was superior to the weather-compensated controller, even if the active heating was necessary.

As mentioned before, the building has up to 12 hour heating delay. During weekends, the building cools down and classical heating has to be launched approximately one day before Monday 8 am, depending on the outside temperature.

5. Remarks to future development

Subspace identification methods represent black-box approach to the system modeling. This, alongside with its advantages carries also some drawbacks:

- The system might not be excited enough [22], i.e. the input of the system does not excite the system on satisfactory number of frequencies, thus identification algorithms lack considerable amount of information.

- User may have knowledge of some key feature or characteristics of the physical essence of the system, which is “lost” in the number of data.
- Natural character of the data might pose considerable statistical problem.

One of the most important aspects of the identification is the persistency of the excitation or the excitation itself. Data gathered from the measurement lack some important physical characteristics of the building. One of the possible approaches how to deal with this weak point is generation of artificial data that already contains desired properties. There is also another possibility, more expensive though—specially proposed experiment. It was decided to perform an experiment on real building in through late December 2009 and early January 2010. The comparison of model identification results is depicted in Fig. 6.

It is obvious, that experimental data significantly improved the identification fit. Yet another approach (and much cheaper) how to

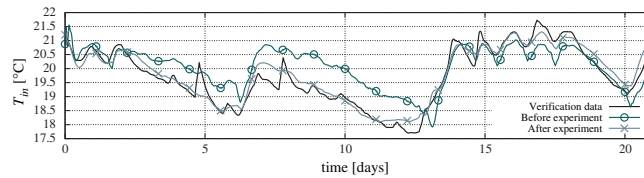

Fig. 6. Validation of model identified from data before and after experiment.

deal with lack of data quality is prior information and its incorporation to the subspace algorithm. Current methods [33] proposed algorithm how to incorporate PI into the algorithm using Bayesian framework. This algorithm makes use of Structured Weighted Lower Rank Approximation (SWLRA) [34] to decompose the projection matrix in order to save special structure, thus keep PI. However, this approach is able to deal with single input single output (SISO) and single input multiple output (MISO) systems only.

Future development of the identification algorithm will try to remedy the above-mentioned problems. Speaking generally, there several approaches to this problem:

- *Bayesian framework.* This approach requires extension to SWLRA algorithm to effectively solve MIMO systems.
- *Incorporation of PI into subspace algorithm.* This approach requires such an computation in subspace identification procedure which enables direct incorporation of PI into system matrices. This approach is the topic of ongoing research.
- *Spectral identification methods.* In robust control, analysis in frequency domain is very popular. The prior information could be incorporated by means of user-defined “filters”. This methodology is also topic of current research.
- *Artificial data.* Generation of data with desired properties is yet another approach. The user incorporates required properties and the knowledge of the physical essence into artificial data which are then used for regular identification. This approach, however, does not explicitly say, how to choose the ratio between artificial and measured data and, therefore, it is only of experimental nature.

In this paper, we treated only predictions of outside temperature because it has dominant influence out of all disturbances affecting the inside temperature. There are, however, other energy sources (like sun intensity, occupancy of the building, etc.). Taking them into account would provide better MPC performance as well as further savings.

6. Conclusion

Predictive control proved to have a great potential in the area of building heating control. The results from real operation on a large university building are very promising and proved the supremacy of predictive controller over a well tuned weather-compensated control, with the savings of 17–24%. The MPC implementation discussed in the present paper is able to track the desired temperature very accurately, thus maintaining the heating comfort of the building.

However, the MPC strategy requires some extra effort. The crucial part of the controller is the mathematical model of the building. This is not possible by traditional system identification techniques based on statistical identification, as the building data usually do not have the desired statistical properties. On the other hand, finding first principle models is time consuming and not suitable for commercial application. We have shown that a proper identification experiment can provide data suitable for statistical

identification, with the help of certain modifications of the standard identification algorithms. Numerical issues of the identification process must be treated very carefully, especially for large-scale systems.

Fortunately, once an appropriate model is found, the MPC tuning is very intuitive and desired properties of the control system can be achieved in a short term. The energy peaks are reduced and the controller does not make fast changes to the control input of the system, which also saves the lifetime of the equipment and reduces the peak energy demands. If desired, it also enables to take different energy prices into account by introducing time-variable tuning parameters into the optimization criterion.

Finally, the decision whether to implement the MPC or not depends largely on the return time of the investments. Even though this largely depends on air temperatures and sunshine during the heating season, the return time for our building is estimated to 2 years. As the identification effort does not really depend on the size of the building, this time will be shorter for large buildings with expensive heating and longer for small buildings with cheap heating.

Acknowledgment

This work has been supported from the state budget of the Czech Republic, through the Ministry of Industry and Commerce, in the scope of grant no. FR-TI1/517, “Control systems for energy consumption optimization in low-energy and passive houses.”.

References

- [1] Buildings and their Impact on the Environment: A Statistical Summary, 2009, rev. April 22, 2009, available on-line at <http://www.epa.gov/greenbuilding/pubs/gbstats.pdf>.
- [2] H.J. Han, Y.I. Jeon, S.H. Lim, W.W. Kim, K. Chen, New developments in illumination, heating and cooling technologies for energy-efficient buildings, *Energy* 35 (6) (2010) 2647–2653.
- [3] J. Wong, H. Li, S. Wang, Intelligent building research: a review, *Automation in Construction* 14 (1) (2005) 143–159, doi:10.1016/j.autcon.2004.06.001.
- [4] L. Peeters, J. Van der Veken, H. Hens, L. Helsens, W. D’haeseleer, Control of heating systems in residential buildings: current practice, *Energy and Buildings* 40 (8) (2008) 1446–1455, doi:10.1016/j.enbuild.2008.02.016.
- [5] S. Soyguder, M. Karakose, H. Alli, Design and simulation of self-tuning pid-type fuzzy adaptive control for an expert hvac system, *Expert Systems with Applications* 36 (3 Part 1) (2009) 4566–4573, doi:10.1016/j.eswa.2008.05.031.
- [6] J. Bai, S. Wang, X. Zhang, Development of an adaptive smith predictor-based self-tuning pi controller for an hvac system in a test room, *Energy and Buildings* 40 (12) (2008) 2244–2252, doi:10.1016/j.enbuild.2008.07.002.
- [7] C. Ghiaus, I. Hazyuk, Calculation of optimal thermal load of intermittently heated buildings, *Energy and Buildings* 42 (8) (2010) 1248–1258, doi:10.1016/j.enbuild.2010.02.017.
- [8] C.P. Underwood, HVAC Control Systems: Modelling, Analysis and Design, E & FN Spon, Great Britain, London, 1999.
- [9] R.Z. Freire, G.H. Oliveira, N. Mendes, Predictive controllers for thermal comfort optimization and energy savings, *Energy and Buildings* 40 (7) (2008) 1353–1365.
- [10] P.-D. Morosan, R. Bourdais, D. Dumur, J. Buisson, Building temperature regulation using a distributed model predictive control, *Energy and Buildings* 42 (9) (2010) 1445–1452, doi:10.1016/j.enbuild.2010.03.014.
- [11] J. Richalet, A. Rault, J.L. Testud, J. Papon, Algorithmic control of industrial process, in: *Proceedings: Symposium on Identification and System Parameter Estimation*, IFAC, Tbilisi, 1976.
- [12] W.H. Kwon, A.M. Bruckstein, T. Kailath, Stabilizing state feedback design via the moving horizon method, *International Journal of Control* 37 (1983) 631–643.

- [13] J.B. Rawlings, J.R. Muske, The Stability of Constrained Receding Horizon Control, *IEEE Transaction on Automatic Control* 38 (10) (1993) 1512–1516.
- [14] A. Zheng, M. Morari, Stability of Model Predictive Control with Soft Constraints, Internal Report, Californian Institute of Technology, 1994.
- [15] P.J. Campo, M. Morari, Robust model predictive control, in: American Control Conference, 1987.
- [16] K. Ang, G. Chong, Y. Li, PID control system analysis, design, and technology, *IEEE Transactions on Control Systems Technology* 13 (4) (2005) 559–576, doi:10.1109/TCST.2005.847331.
- [17] Y. Li, K. Ang, C. Chong, PID control system analysis and design—problems, remedies, and future directions, *IEEE Control Systems Magazine* 26 (1) (2006) 32–41.
- [18] J.M. Maciejowski, *Predictive Control with Constraints*, Prentice Hall, 2002.
- [19] T.Y. Chen, Application of adaptive predictive control to a floor heating system with a large thermal lag, *Energy and Buildings* 34 (1) (2002) 45–51.
- [20] M. Gwerder, J. Tödtli, B. Lehmann, F. Renggli, V. Dorer, Control of thermally activated building systems, in: Proceedings: 9th REHVA World Congress Clima, 2007.
- [21] Z. Liao, A. Dexter, An inferential model-based predictive control scheme for optimizing the operation of boilers in building space-heating systems, *IEEE Transactions on Control Systems Technology* 18 (5) (2010) 1092–1102, doi:10.1109/TCST.2009.2033667.
- [22] L. Ljung, *System Identification: Theory for User*, Prentice-Hall, 1999.
- [23] M. Verhaegen, V. Verdult, *Filtering and System Identification: A Least Squares Approach*, Cambridge University Press, 2007.
- [24] T. Bohlin, *Practical Grey Box Process Identification*, Springer, 2006.
- [25] V. Peterka, Bayesian system identification, *Automatica* 17 (1) (1981) 41–53.
- [26] L. Ferkl, J. Široký, Ceiling radiant cooling: comparison of ARMAX and subspace identification modelling methods, *Building and Environment* 45 (1, Sp. Iss. SI) (2010) 205–212.
- [27] P. Van Overschee, B. De Moor, *Subspace Identification for Linear Systems*, Kluwer Academic Publishers, 1999.
- [28] H. Kwakernaak, R. Sivan, *Linear Optimal Control Systems*, John Wiley & Sons, 1972.
- [29] P. Trnka, *Subspace identification methods*, Ph.D. Thesis, Czech Technical University in Prague, 2007.
- [30] E.F. Camacho, C. Bordons, *Model Predictive Control*, Springer, London, 1999.
- [31] R.G. Crittall, J.L. Musgrave, Heating and cooling of buildings, GB Patent No. 210880 (April 1927).
- [32] J. Široký, L. Ferkl, Model of a hot water full circulation mode in a building, in: IEEE International Conference on Control and Automation. ICCA 2009, 2009, pp. 585–590, doi:10.1109/ICCA.2009.5410421.
- [33] P. Trnka, V. Havlena, Subspace like identification incorporating prior information, *Automatica* 45 (4) (2009) 1086–1091.
- [34] M. Schuermans, P. Lemmerling, S.V. Huffel, Block-row hankel weighted low rank approximation, *Numerical Linear Algebra with Applications* 13 (2006) 293–302.

3.2 MODELING CRUCIAL FOR BUILDING PREDICTIVE CONTROL

Energy and Buildings paper entitled *Building modeling as a crucial part for building predictive control* guides a reader through a variety of identification and modeling approaches for building with a special emphasis on those suitable for predictive control.

Apart from the review of the building modeling approaches a new approach based on combination of the building energy performance simulation tools and statistical identification is introduced. The procedure is based on the so called co-simulation that has appeared recently as a feature of various building simulation software packages. The whole concept is demonstrated on the real office building in Munich.

The share of the author on the result according to VVVS is 49%.

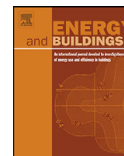

Building modeling as a crucial part for building predictive control[☆]

Samuel Prívvara^{a,*}, Jiří Cigler^a, Zdeněk Váňa^a, Frauke Oldewurtel^b, Carina Sagerschnig^c, Eva Žáčková^a

^a Department of Control Engineering, Faculty of Electrical Engineering, Czech Technical University in Prague, Czech Republic

^b Power Systems Laboratory, Department of Electrical Engineering, Swiss Federal Institute of Technology in Zurich (ETHZ), Physikstrasse 3, 8092 Zurich, Switzerland

^c Gruner AG, Gellerstrasse 55, CH-4020 Basel, Switzerland

ARTICLE INFO

Article history:

Received 18 September 2012

Received in revised form 6 October 2012

Accepted 10 October 2012

Keywords:

Building modeling

Predictive control

Co-simulation

HVAC control

ABSTRACT

Recent results show that a predictive building automation can be used to operate buildings in an energy and cost effective manner with only a small retrofitting requirements. In this approach, the dynamic models are of crucial importance. As industrial experience has shown, modeling is the most time-demanding and costly part of the automation process. Many papers devoted to this topic actually deal with modeling of building subsystems. Although some papers identify a building as a complex system, the provided models are usually simple two-zones models, or extremely detailed models resulting from the use of building simulation software packages. These are, however, not suitable for predictive control. The objective of this paper is to share the years-long experience of the authors in building modeling intended for predictive control of the building's climate. We provide an overview of identification methods for buildings and analyze their applicability for subsequent predictive control. Moreover, we propose a new methodology to obtain a model suitable for the use in a predictive control framework combining the building energy performance simulation tools and statistical identification. The procedure is based on the so-called co-simulation that has appeared recently as a feature of various building simulation software packages.

© 2012 Elsevier B.V. All rights reserved.

1. Introduction

1.1. Motivation for advanced control in buildings

Building climate control has drawn a lot of attention in recent years in both academia and industry. Buildings account for 20–40% of the total final energy consumption, and in the developed countries, the amount per year increases at a rate 0.5–5% [1]. In addition, the building sector is responsible for 33% of global CO₂ emissions. The savings related to buildings are therefore a natural objective of many research groups. Apart from retrofitting and modernization, one of the most popular current approaches is the application of advanced control strategies to the building automation systems (BAS) or to some of their parts.

1.2. Current control approaches, trends and possible improvements

Even though a number of advanced control solutions have been suggested by researches, the most widely used method in building

temperature control has been until recently a controller supervised by heating-curve (HC) which require no model of the process (see e.g. [2,3]). The respective subsystems of heating, ventilation, and air conditioning (HVAC) are then controlled making use of rule-based controllers (RBC, “if-then-else”) [4], which are mainly responsible for a specific and space-limited area. On the level of the whole building, there is no optimization (even though there are often highly sophisticated local controllers). This is caused by extreme complexity of the respective RBCs and the fact that it is practically impossible to generalize their rules for the building level. This problem becomes even more severe in view of the rising complexity of BAS tasks in modern office buildings.

One can distinguish two main research directions in advanced HVAC control (i) learning based approaches of artificial intelligence (AI) like neural networks, genetic algorithms, fuzzy techniques, support vector machines, etc. (ii) Model predictive control (MPC) techniques that stand on the principles of classical control. Generally, learning based techniques are easier to implement (if lots of on-site measurements are available) but the subsequent AI model is not suitable for optimization, lacks a physical insight and does not deal well with changes as caused by varying occupancy behavior or physical changes in the building.

MPC is a well established method for constrained control and has also been in focus of researchers in the area of buildings [5–9]. Among the first notes about MPC for supervisory control of a building was the work presented by [10], however, due to the

[☆] The results in paper were partly written during the visit at IfA, ETH Zurich.

* Corresponding author at: Department of Control Engineering, Faculty of Electrical Engineering, Czech Technical University in Prague, Technická 2, 166 27 Praha 6, Czech Republic. Tel.: +420 776 697 672.

E-mail address: samuel.privara@fel.cvut.cz (S. Prívvara).

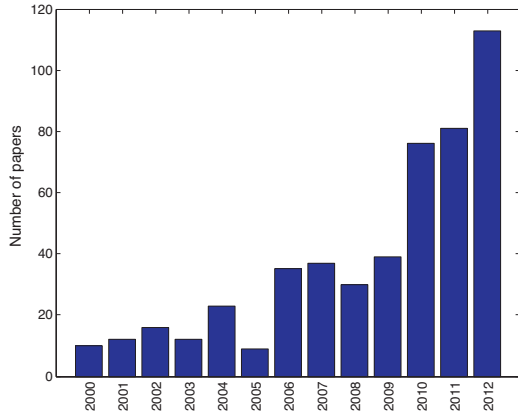

Fig. 1. Number of papers devoted to MPC in buildings in journals Energy and Buildings, Building and Environment and Energy.

computational demands, this framework has not received much attention until the past decade when MPC was applied to various types of buildings systems often using standard simulation tools. The growing interest in the use of MPC for buildings is well demonstrated by Fig. 1. Lately, the concept of predictive control has found a way to the practical applications as well [5,11,12].

MPC opens up possibilities of exploiting thermal storage capacities. It makes use of prediction of future disturbances (internal gains due to people and equipment, weather, etc.) given requirements such as comfort ranges (single value set-points still remains possible to set) for controlled variables. The control ranges (constraints) are either known in advance or at least estimated for controlled variables, disturbances, control costs, etc.

1.3. Dynamic model as a crucial part of MPC

Reliable predictions from the identified dynamic model are crucial for a sound performance of MPC. It is a well-known fact that modeling and identification are the most difficult and time-consuming parts of the automation process as such [13], particularly for predictive control. The basic conditions that each model intended for MPC usage should satisfy are reasonable simplicity, well estimated system dynamics and steady-state properties as well as satisfactory prediction properties. These requirements do not need to be of the same quality on the whole frequency range, rather they should comply with the quality requirements for the control-relevant frequency range (see e.g. [14–16]). The key question therefore is what kind of model should be searched for?

Two basic paradigms to derive a total model of building dynamics are at hand. The first one originated in HVAC engineering and building automation communities, a “traditional” approach, which uses knowledge of the structure and physical and material properties of a building. A detailed building model is then assembled from simple subsystems mutually physically interacting, making use of computer aided modeling tools, e.g. Trnsys [17], EnergyPlus [18], ESP-r [19], etc. Their objective is to simulate the behavior of the building, however, they do not provide an explicit model,¹ thus can be hardly classified into control oriented modeling approaches even

¹ Note that in this context, we call a model explicit if there are mathematical formulas describing a state evolution, i.e. a set of differential or difference equations is available. Otherwise the model is called implicit. Notice that AI models are also implicit.

though there is a challenging project GenOpt aiming at employing a (predictive) control framework directly without the need of a simple model [20]. This is however very computationally demanding, hardly scalable and therefore not further considered here.

An alternative is to use statistically based, i.e. data-driven approaches, resulting in a model in an explicit form. We must emphasize that even physically-based parametric models are classified into statistically-based models here as the parameters are identified using measured or simulated data.

Basically, following categories of building modeling techniques suitable for predictive control that can be considered as statistical.

Subspacemethods(4SID) [21] belong to the black-box identification algorithms and provide a model in a state space form.

The main advantage of 4SID methods is their ability to handle large amount of data. This was demonstrated for instance in the identification of a thermodynamic model of a small residential building that was equipped with tens of wireless sensors collecting temperatures, humidity and solar radiation [22]. 4SID methods were also used for an identification of a university building: at first, the authors compared prediction error methods with 4SID methods [23], then showed that a suitable identification experiment can significantly increase quality of the resulting model [24] as the quality of input–output data is a key factor for 4SID methods. Further on, 4SID algorithm was also applied for the identification of a large office building [25].

Predictionerror methods(PEM) [26] are the most commonly used statistical identification techniques. Their objective is to minimize one-step ahead prediction error by optimizing parameters of a prespecified model structure.

Typically, autoregressive moving average with external input (ARMAX) model structures are preferred. This structure is used for modeling of a room temperature in office buildings as presented in [27], the model is then used for real-time fault detection and control applications. In [28], several black-box model structures are investigated for identification of the thermal behavior of a modern office building. The authors conclude that Box–Jenkins general model results in the best prediction performance among the studied group.

PEM are simple-to-use methods that are, however, suitable mainly for identification of single-input single-output (SISO) systems. As the building systems are normally multiple-input multiple-output (MIMO) systems, these methods have to be carefully used. In [29], the authors show that modeling of air conditioning process by multiple SISO ARMAX models of all system components leads to poor performance compared to the proposed MIMO ARMAX counterpart.

MPCrelevant identification(MRI) is an approach minimizing multi-step ahead prediction errors [30–32]. The horizon for error minimization commensurate with the prediction horizon of the predictive controller.

A multi-step ahead prediction error cost function for selection of a building model is examined in [33]. The authors adapts the MRI algorithm for usage on building data that are usually highly correlated and then show that the proposed algorithm results outperforms standard one-step ahead PEM methods.

Deterministicsemi – physical modeling(DSPM) uses resistance capacitance (RC) network analogue to an electric circuitry to describe the process dynamics and is often referred to as a gray-box modeling.

This approach was presented in a wide variety of papers. Gray-box technique is used to obtain a model of a university building in [11]. With this model, the MPC applied in a real operation saved 16–28% energy compared to the previous well-tuned conventional control strategy. RC networks are also used by the leading projects dealing with predictive control of buildings, i.e. UC Berkeley [5], ETH Zurich [34], KU Leuven [6].

Besides that, [35] shows how to use identification toolbox for Matlab [36] to estimate parameters of RC networks, while in [37], the authors estimate building parameters using genetic algorithms minimizing one-step prediction error. Detailed RC network for thermally activated building systems (TABS) is presented in [38].

Probabilisticsemi – physical modeling (PSPM) [39] utilizes stochastic differential equations for the description of a system to be identified. A hierarchy of models with increasing complexity is formulated based on prior physical knowledge, parameters of each model are estimated using the maximum likelihood (ML) method and a forward selection strategy is used to find a meaningful and adequately complex model by an iterative process.

This technique is presented in a series of papers by [40,41], the additional statistical tests for the iterative procedure are proposed in [42].

1.4. The contribution and a structure of the paper

Following the discussion in the previous paragraphs, MPC has a potential to address the issue of energy consumption in buildings as well as growing complexity of control requirements. The crucial part of MPC is the dynamic model. The objective of this paper is to (i) present a review of methods applicable to the building modeling intended for the predictive control and (ii) address an issue of handling of the growing complexity of modern buildings.

The paper continues with the following structure. The next section is devoted to building modeling and identification approaches – those well-known in control engineering community as well as those originating from the community of building and civil engineers. Section 3 is devoted to a novel method combining a building modeling software with a subsequent statistical identification. This approach can be conveniently used for large office buildings. Section 4 presents two case studies: the first is an artificial example of a simple, yet realistic building constructed in Trnsys environment, where the properties of several identification approaches are shown, while the second is a statistically-based identification of a large office building in Munich. To the best of the authors' knowledge, there was no detailed building modeling of such size intended for predictive control as is discussed there. The last section contains final remarks and concludes the paper.

1.5. Notation

Throughout the paper \mathbb{R} denotes the set of reals, \mathbb{Z} set of integers, $t \in \mathbb{R}$ the time while $k \in \mathbb{Z}$ is the discrete time, vectors $u \in \mathbb{R}^m$, $x \in \mathbb{R}^n$, $y \in \mathbb{R}^r$ stand for system input, state and output, respectively. The symbols $w \in \mathbb{R}^n$ and $e \in \mathbb{R}^r$ denote process and measurement noise sequences, respectively. The positive integer N stands for number of identification data while P is the length of an MPC prediction horizon. Notation Z_1^j means that matrix Z_1^j is composed as $Z_1^j = [z_1, z_2, \dots, z_j]$. The symbol $(\cdot)^{\dagger}$ stands for Moore–Penrose pseudo-inverse of a matrix, whilst the symbol \hat{M} means the estimate of quantity M . The symbol I_s stands for the identity matrix of size s . Finally, the symbols $\text{vec}(\bullet)$ and \otimes denote the vectorization and the Kronecker product, respectively.

2. Modeling and identification for buildings

In the following, two basic concepts for derivation of a building model are treated in detail. First, we deal with an approach using a building simulation software, and thereafter we will have a look at statistically-based approaches.

2.1. Physically-based models, simulation tools

Physically-based models are typically developed making use of specialized computer aided modeling tools. The particular tool then assembles the model from the provided information about building structure and physical and material properties. A detailed building model is then assembled from simple subsystems mutually physically interacting. Overall, the software packages are called building energy performance simulation tools (BEPST).

2.1.1. Application of a building energy performance simulation

The building energy performance simulation has become an important tool to assess the building's energy consumption and user comfort. In early design phases architects and designers mostly use BEPST to compare performance of different design variants. The simulation inputs are based on the designer's experience since not all design decisions are finalized yet. The building's energy performance simulated at these stages may vary greatly from the actual building's energy performance once it is in operation. It is however possible to deduce tendencies of expected performance of different design solutions in early design stages.

Application of BEPST is not limited to the early design phases. In more detailed design phases the building simulation is often used to check the functionality of a proposed design and increase the planning reliability. In addition, the building simulation is increasingly employed to evaluate an absolute energy performance which requires a greater level of detail for all energy consuming building and plant components.

The level of detail for modeling HVAC plants depends on the available building data. For gathering all the information needed to model a building and its plants, a close cooperation of technical consultants for architecture, HVAC and electrical and the building owner is necessary. In early design phases, issues of building control are often postponed to detailed planning. Simulation engineers thus often fall back on implementing standardized and simplified control rules in their models.

2.1.2. Control in building energy performance simulation tools

Currently available BEPST have quite different control capabilities. Typically, simulation tools provide thermostat and humidistat control as well as pre-defined control strategies for system availability and plant control. Because BEPST use idealized approximations, control in simulation tools performs more efficient and stable as it might be in real-world applications. Thus, the calculated building energy consumption is generally optimistic [43].

2.2. Statistically-based identification approaches

The building modeling approaches described in the following are in-line with the short discussion from Section 1.3.

2.2.1. Subspace identification

Buildings usually have tens or even hundreds of rooms/zones with a large number of actuators and sensors, what results in MIMO model.

One of the most popular and successful methods for identification of MIMO systems is subspace state-space system identification (4SID).

Problemstatement. The objective of the 4SID is to find matrices A , B , C , D and K of a linear time-invariant (LTI) discrete-time model in an innovative form:

$$\begin{aligned} x_{k+1} &= Ax_k + Bu_k + Ke_k, \\ y_k &= Cx_k + Du_k + e_k \end{aligned} \quad (1)$$

Table 1
Symbols and their meaning used for 4SID algorithm.

Symbol	Meaning
Y_p	Hankel matrix of the past outputs
Y_f	Hankel matrix of the future outputs
X_p	Hankel matrix of the past states
X_f	Hankel matrix of the future states
U_p	Hankel matrix of the past inputs
U_f	Hankel matrix of the future inputs
Γ_i	Extended observability matrix
H^d	Markov parameter matrix corresponding to the deterministic part
H^s	Markov parameter matrix corresponding to the stochastic part
Δ^d	Reversed extended controllability matrix corresponding to the deterministic part
Δ^s	Reversed extended controllability matrix corresponding to the stochastic part
E_p	Hankel matrix of the past noise
E_f	Hankel matrix of the future noise
i	Number of block rows in Hankel matrices

based on given measurements of an input and an output generated by an unknown stochastic system of order n subject to unknown white noise e_k .

Algorithm. The entry point is the input–output equations:

$$Y_p = \Gamma_i X_p + H_i^d U_p + H_i^s E_p, \quad (2)$$

$$Y_f = \Gamma_i X_f + H_i^d U_f + H_i^s E_f, \quad (2)$$

$$X_f = A^i X_p + \Delta_i^d U_p + \Delta_i^s E_p, \quad (2)$$

where the symbols are defined in Table 1. Note that a very detailed explanation of the respective symbols, e.g. how the Hankel matrices are constructed is provided in [21,44]. The basic idea of the algorithm is to drop input and noise matrices by finding an appropriate projection and instrument matrices. The main tool of 4SID is an oblique projection defined as follows [21]:

$$\mathfrak{Z} = Y_f / W_p = Y_f \begin{bmatrix} W_p^T & U_f^T \\ U_f W_p^T & U_f U_f^T \end{bmatrix} \begin{bmatrix} W_p W_p^T & W_p U_f^T \\ U_f W_p^T & U_f U_f^T \end{bmatrix}^{-1} \begin{bmatrix} I_r \\ 0 \end{bmatrix} W_p, \quad (3)$$

where $W_p = (U_p/Y_p)$, i.e. the matrices of past inputs and outputs are stacked onto each other. The equation basically represents the projection of future system outputs onto a space of past system inputs. Then it can be shown [21] that $\mathfrak{Z} = \Gamma X$, where X is the Kalman filter state sequence and Γ is state observability matrix. The order of the system can be determined from an analysis of singular values obtained from a singular value decomposition (SVD) of $W_1 \mathfrak{Z} W_2$, where $W_{1,2}$ are weighting matrices of an appropriate size which determine the resulting state space basis as well as the importance of the particular element of \mathfrak{Z} , see Eq. (8).

The algorithm continues from either Γ or X in a slightly different manner depending on the particular subspace identification algorithm, however, both ways lead to a computation of A and C by ordinary least squares (OLS).

For selection of a submatrix we have adopted a Matlab-like notation, where $A(1:n, :)$ means that the submatrix is obtained from the original matrix A by taking 1 to n rows and all the columns. Then

$$\hat{C} = \Gamma(1:r, :), \quad (4a)$$

$$\hat{A} = \Gamma(1:(i-1)*r, :)^{-1} \Gamma(r+1:i*r, :). \quad (4b)$$

Given \hat{A} and \hat{C} , the estimate of B and D (and an initial state x_0) is performed in different ways [21,26,45–47]; here the general idea will

be outlined. The system output equation of Eq. (1) can be written as:

$$y_k = CA^k x_0 + \sum_{j=0}^{k-1} CA^{k-j-1} B u_j + D u_k + e_k. \quad (5)$$

Note that in this equation, the only unknowns are x_0 and matrices B and D . The rest of the terms are known or can be replaced by the estimates. With aid of vectorization and Kronecker product, the equation can be rewritten into a form of a least-squares problem. For more details, consult [48].

Finally, given the estimates of A, B, C, D , the Kalman gain matrix K can be computed solving the Algebraic Riccati Equation (ARE) in which the covariance matrices Q, S and R :

$$\begin{bmatrix} Q & S \\ S^T & R \end{bmatrix} = \frac{1}{N} \begin{bmatrix} W \\ V \end{bmatrix} \begin{bmatrix} W^T & V^T \end{bmatrix} \quad (6)$$

are determined from the residuals as follows:

$$\begin{bmatrix} W \\ V \end{bmatrix} = \begin{bmatrix} X_{k+1} \\ Y_k \end{bmatrix} - \begin{bmatrix} \hat{A} & \hat{B} \\ \hat{C} & \hat{D} \end{bmatrix} \begin{bmatrix} X_k \\ U_k \end{bmatrix} \quad (7)$$

At last, a short note on choice of a system order is given. Two possible approaches are at hand.

- The oblique projection matrix is decomposed by SVD and then the system order is determined as a number of non-zero singular values of \mathfrak{Z} matrix in $SVD(W_1 \mathfrak{Z} W_2) = U \Sigma V^T$,
- In case of worse signal to noise ratio, the estimation of the number of dominant singular values becomes cumbersome. An alternative heuristic approach improving the order estimation is suggested as:

$$\begin{aligned} f(\sigma_j) &= \text{grad} \log(\sigma_j) \quad j = 1, \dots, i \cdot r, \\ n &= \underset{j}{\text{argmin}} f(\sigma_j), \end{aligned} \quad (8)$$

where σ_j are singular values of \mathfrak{Z} . Note that this heuristic can be used in situations, when there is a low signal to noise ration, thus the singular values are “drowned” in the noise.

Subspace identification forbi – linearsystems.

Some phenomena in buildings cannot be modeled using linear physics by their nature. These are, for instance, operation of ventilation units [49] or the heat transmission through the windows [34]. The latter is caused by opening and closing the blinds (which can be controlled by MPC). The effects of the blinds on the dynamics can be modeled by splitting the heat transmission [34]. The first part describes the heat transmission with closed blinds (constant), whilst the second part describes the heat transmission with the partially or fully opened blinds. This means, that for the partially or fully opened blinds, the system state is multiplied by an input $u \in \{0, 1\}$, which forms a bi-linear system description. A product of mass flow rate and a temperature (to obtain a heat flux) results in another example of a bi-linearity. Bi-linearities are treated in detail in [5].

A possible solution is to use bi-linear subspace algorithm (Bi4SID). The objective of Bi4SID is to find a bi-linear, time-invariant, discrete time model in a form:

$$x_{k+1} = Ax_k + F(x_k \otimes u_k) + Bu_k + w_k, \quad (9)$$

$$y_k = Cx_k + Du_k + e_k.$$

The objective of the algorithm is to determine the system order n and to find the matrices A, B, D, C and F up to some similarity transformation.

The biggest disadvantage of the Bi4SID is that the number of rows of data matrices grows exponentially with the order of the system [50,51]. This drawback was to a great extent overcome by kernel method [51,52], where used kernel data matrices have smaller dimensions than those used in original bi-linear subspace problem. As an alternative to the kernel method, the basic OLS problem has been reformulated as a Ridge regression problem [52], where for solution the only kernel matrix is needed. Even with these simplifications, Bi4SID are not yet applicable to the real building as they are unable to process larger amounts of data.

2.2.2. Prediction error methods

Prediction error methods [26] (PEM) are frequently used for system identification and can be formulated as:

$$\hat{\theta} = \underset{\theta}{\operatorname{argmin}} \sum_{k=1}^N \ell(\varepsilon_k(\theta)), \quad (10)$$

where $\ell(\bullet)$ is an appropriate scalar-valued function, θ is a vector of parameters and ε_k a prediction error in time k , $\varepsilon_k = y_k - \hat{y}_k$, with \hat{y}_k denoting the output estimate. Typically, one-step ahead prediction is to be minimized which uses past output data up to time $k-1$ to obtain the estimate of y_k . This is formally written as $\hat{y}_{k|k-1} = f(U_1^k, Y_1^{k-1})$. The function f depends on the user's choice of model structure (ARX, ARMAX, etc.).

2.2.3. Model predictive control relevant identification

When building-up a model for MPC, we should think about the minimization of the control error on the prediction horizon. Hence a model used for predictive control should be primarily a sound multi-step predictor. Such methods, minimizing the multi-step prediction error, are collectively called MPC relevant identification methods (MRI) [32,53–55] and in some sense extend PEM. These methods are addressed in detail in the following.

Problemstatement. A possible formulation of a basic MPC problem can be as follows:

$$\min_{u_0, \dots, u_{p-1}} \sum_{k=0}^{p-1} (y_k^{\operatorname{ref}} - y_k)^T Q_k (y_k^{\operatorname{ref}} - y_k) + R_k u_k, \quad (11)$$

$$\text{subject to: } x_0 = x, \quad (12)$$

$$x_{k+1} = f(x_k, u_k), \quad (13)$$

$$y_k = g(x_k, u_k), \quad (14)$$

$$(x_k, u_k, y_k) \in \mathcal{X}_k \times \mathcal{U}_k \times \mathcal{Y}_k, \quad (15)$$

where $\mathcal{X}_k, \mathcal{U}_k$ and \mathcal{Y}_k denote the constraints sets of states, inputs and outputs. Q_k and R_k are time varying weighting matrices of appropriate dimensions. Based on Eq. (11), without penalization on control, the MPC cost function which penalizes the sum of the squared differences of the actual value of the controlled output y_k and the required reference y_k^{ref} during a prediction horizon can be rewritten as:

$$J_{\operatorname{MPC}} = \frac{1}{(N-P)P} \sum_{k=1}^{N-P} \sum_{i=1}^P (y_{k+i}^{\operatorname{ref}} - y_{k+i})^2 \quad (16)$$

For buildings, P is typically chosen such that it corresponds to 48 h, while N is significantly larger. Next, $y_{k+i} = \hat{y}_{k+i|k} + e_{k+i|k}$, where $\hat{y}_{k+i|k}$ denotes the predicted output values at the time $k+i$ using

the data until k , $e_{k+i|k}$ is the i -step ahead prediction error. Eq. (16) can be rewritten [53] as:

$$\begin{aligned} J_{\operatorname{MPC}} &= \frac{1}{(N-P)P} \sum_{k=1}^{N-P} \sum_{i=1}^P (y_{k+i}^{\operatorname{ref}} - y_{k+i})^2 \\ &+ \frac{1}{(N-P)P} \sum_{k=1}^{N-P} \sum_{i=1}^P (y_{k+i} - \hat{y}_{k+i|k})^2 \\ &- \frac{2}{(N-P)P} \sum_{k=1}^{N-P} \sum_{i=1}^P (y_{k+i}^{\operatorname{ref}} - \hat{y}_{k+i|k})(y_{k+i} - \hat{y}_{k+i|k}). \end{aligned} \quad (17)$$

The MPC itself minimizes only the first term. However, from global perspective, to achieve the optimal solution it is necessary minimize the remaining terms as well. The last term represents the cross-correlation between the identification and control errors and is treated by [56]. The second term in Eq. (17) will be used as an identification loss function for MRI and expresses the identification error:

$$J_{\operatorname{MRI}} = \frac{1}{(N-P)P} \sum_{k=1}^{N-P} \sum_{i=1}^P \|e_{k+i|k}\|^2 = \|E_a\|^2, \quad (18)$$

or with explicit dependence on estimated parameters as:

$$J_{\operatorname{MRI}}(\Theta) = \|E_a\|^2 = \|Y_a - Z_a(\Theta)\Theta\|^2 \quad (19)$$

with

$$E_a = \begin{bmatrix} E_{a_1} \\ \vdots \\ E_{a_p} \end{bmatrix}, \quad E_{a_i} = \begin{bmatrix} e_{1+i|1} \\ \vdots \\ e_{N|N-i} \end{bmatrix}, \quad i = 1, \dots, P \quad (20)$$

and similarly defined output matrix Y and regressor Z . The specific form of regressor depends on the model used.

2.2.4. Estimation of ARX models

In case that AutoRegressive eXternal input (ARX) [26] model is considered, the multi-step output prediction $\hat{y}_{k+i|k}$ is expressed as:

$$\hat{y}_{k+i|k} = Z_{k+i} \hat{\Theta}, \quad i = 1, 2, \dots, P. \quad (21)$$

where $Z_{k+i} = [u_{k+i-n_k}, \dots, u_{k+i-n_b}, y_{k+i-1}, \dots, y_{k+i-n_a}]$ and $\hat{\Theta} = [\hat{b}_{n_k}, \dots, \hat{b}_{n_b}, \hat{a}_1, \dots, \hat{a}_{n_a}]^T$, n_b and n_a are the numbers of lagged inputs and outputs, n_k represents the relative lag of outputs w.r.t. to inputs. As the outputs y_{k_0} in Z_{k+i} with $k_0 > k$ are not available at k , the output prediction $\hat{y}_{k_0|k}$ is obtained recursively from Eq. (21), i.e. by an iterative use of one-step ahead predictions. Having formed the Z_a and Y_a according to Eq. (20), the problem can be solved by available solvers minimizing Eq. (19).

2.2.5. Estimation of state space models

When minimizing Eq. (19) for MIMO system, the use of the state space representation is more convenient than e.g. ARX parametrization. In the simplest case when all the states are measurable, the relation between $\hat{\Theta}$ and system matrices A and B can be expressed as:

$$\hat{\Theta} = \begin{bmatrix} A \\ B \end{bmatrix}, \quad (22)$$

that is, if all the states are measured (C is a unit matrix), matrices A and B can be readily extracted from $\hat{\Theta}$.

The more difficult situation is for the case when some states are not measured and the particular input and output pair is represented by a higher-order transfer function $n_b > 1$ for the j th input.

The basic idea is to introduce artificial outputs (by means of A_{aux} and B_{aux}) and make thus all the states “measurable”. The respective parameters are estimated by MRI minimizing Eq. (19) using MIMO ARX structure.

Without loss of generality, let us assume that the output which depends on the lagged input is the first one. Then $n_b - 1$ auxiliary variables in matrices A_{aux} and B_{aux} are introduced:

$$\begin{bmatrix} x_{n_o+1,k+1} \\ \vdots \\ x_{n_o+n_b-1,k+1} \end{bmatrix} = A_{aux} \begin{bmatrix} x_{n_o+1,k} \\ \vdots \\ x_{n_o+n_b-1,k} \end{bmatrix} + B_{aux}u, \quad (23)$$

where A_{aux} and B_{aux} are in the following form:

$$A_{aux} = \begin{bmatrix} 0 & 1 & 0 & \cdots & 0 \\ 0 & 0 & 1 & 0 & \vdots \\ \vdots & & \ddots & & \vdots \\ 0 & \cdots & & \cdots & 0 \end{bmatrix}, \quad (24)$$

$$B_{aux} = \begin{bmatrix} \mathbf{0}_{j-1} & \begin{bmatrix} 0 \\ \vdots \\ 0 \\ 1 \end{bmatrix} & \mathbf{0}_{n_i-j} \end{bmatrix}, \quad (25)$$

with $\mathbf{0}_{j-1}$ and $\mathbf{0}_{n_i-j}$ being appropriate size zero matrices and n_i and n_o being number of inputs and outputs, respectively. Then, the system matrices \bar{A} , \bar{B} can be expressed as:

$$\bar{A} = \begin{bmatrix} A & \begin{bmatrix} b_{n_b,j} & b_{n_b-1,j} & \cdots & b_{2,j} \\ 0 & 0 & \cdots & 0 \\ \vdots & & \ddots & \vdots \\ 0 & \cdots & & 0 \end{bmatrix} \\ \mathbf{0} & A_{aux} \end{bmatrix}, \quad \bar{B} = \begin{bmatrix} B \\ B_{aux} \end{bmatrix} \quad (26)$$

with A and B in Eq. (26) computed analogously to Eq. (22) leaving out the coefficients corresponding to the influence of the lagged input (this is equivalent to $n_a = n_b = 1$). The skipped coefficients are stored in the last $n_b - 1$ elements of the first row of \bar{A} . Note that j denotes the lagged input channel. Similar procedure is used in the case when more than one output is affected by the lagged input. Matrix C is a matrix with as many rows as system outputs (original, without artificial outputs created by introducing the auxiliary states) and as many columns as system states. Matrix D is a zero matrix.

2.2.6. Deterministic semi-physical modeling

As already stated, DSPM uses RC network analogue to electric circuitry to describe internal workings. To detail this approach, we first need to consider all kinds of heat transfers to assemble a detailed first principles model.

Conduction is a heat transfer through walls (solid body) expressed as [57]:

$$\dot{T}_2 \approx \frac{T_1 - T_2}{k_{cd}} \approx \frac{\dot{Q}}{k_{cd}}, \quad (27)$$

where T_1 is a temperature of a source, T_2 is a measured temperature of some entity, \dot{Q} is a heat flux and k_{cd} stands for the conduction time constant of a process ($R \times C$ with R and C being the thermal resistance and capacity of a mass).

Convection is a heat transfer through air (liquid) expressed as:

$$\dot{T}_2 \approx \frac{T_1 - T_2}{k_{cv}} \cdot \sqrt[4]{\frac{T_1 - T_2}{T_1 + T_2}} \quad (28)$$

with a time constant k_{cv} . Eq. (28) can also be approximated by $\dot{T}_2 \approx (T_1 - T_2)/K_{cv}$ as $\sqrt[4]{(T_1 - T_2)/(T_1 + T_2)}$ is considered constant for a building heating process [57].

Radiation corresponds (similar as a convection) to a heat transfer through air and is expressed as:

$$\dot{T}_2 \approx \frac{T_1^4 - T_2^4}{k_{ra}} \quad (29)$$

with time constant k_{ra} .

Based on the simplified equations for all heat transfers, differential equations can be formulated for all states/nodes. This is schematically outlined in Fig. 2. Control actions are introduced in two ways. The first one involves simply adding a heating or cooling input to the particular room node, which then appears in the right-hand side of above mentioned equations. The second way of introducing control actions is by assuming that some resistances are variable. For example, solar heat gains and luminous fluxes through windows are assumed to vary in a linear fashion with a blind position, i.e. the corresponding resistance was multiplied with an input $u = (0, 1)$. This leads to a bi-linear model, i.e. bi-linear in a state and input and a disturbance and input as well.

Now we will briefly outline a simple procedure how to estimate parameters of a RC network. Other procedures exist and are usually based on the computationally demanding parameter estimation of differential equations that are solved by sequential quadratic programming. We rather present numerically simple and stable procedure based on least squares technique. The procedure was firstly used by [11].

DSPM estimation procedure. Having described a physics of a building by a set of differential equations, the estimation problem is formulated in the continuous time. Most of the mathematical tools, however, work with discrete-time counterparts, therefore the original continuous-time problem must be reformulated to a discrete world, e.g. as:

$$A = e^{A_c T_s} = I_n + A_c T_s + \frac{A_c^2 T_s^2}{2} + \dots \approx I_n + A_c T_s,$$

$$B = \int_0^{T_s} e^{A_c \tau} d\tau \approx \int_0^{T_s} I_n d\tau B_c = T_s B_c,$$

where A_c , B_c and A , B are model matrices of continuous- and discrete-time models, respectively. T_s stands for a sampling time. This corresponds to the Euler's discretization, thus can be applied for non-linear systems as well. Then the state equation $x_{k+1} = Ax_k + Bu_k + e_k$ developed over the time can be written as:

$$X_2^N = AX_1^{N-1} + BU_1^{N-1} + E_1^{N-1} = \quad (30)$$

$$= \begin{bmatrix} A & B \end{bmatrix} \begin{bmatrix} X_1^{N-1} \\ U_1^{N-1} \end{bmatrix} + E_1^{N-1} \quad (30)$$

For standard optimization using OLS, Eq. (30) is rewritten as:

$$\text{vec} X_2^N = \left(\begin{bmatrix} X_1^{N-1} \\ U_1^{N-1} \end{bmatrix} \otimes I_n \right)^T \text{vec} \begin{bmatrix} A & B \end{bmatrix} + \text{vec} E_1^{N-1}.$$

Extra lines for a structure preservation of A and B as well as other required constraints can be added into the regressor matrix and the left-hand side matrix. Then, the unknown parameters are estimated using a weighted LS technique.

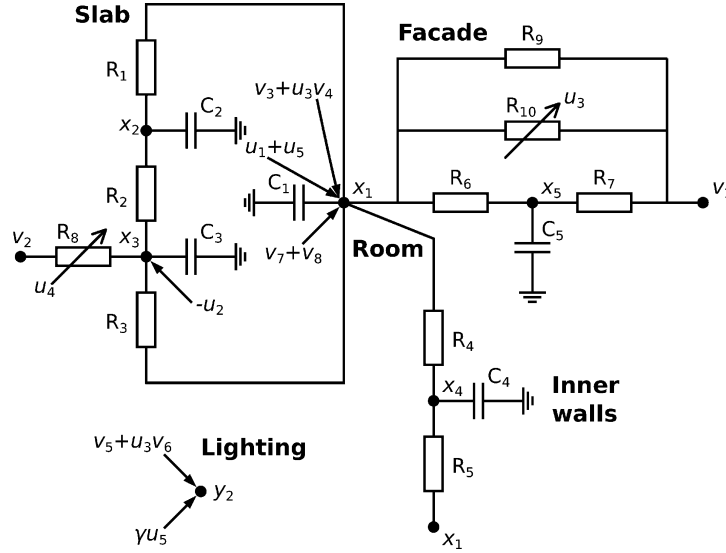

Fig. 2. RC network representing a building model.

2.2.7. Probabilistic semi-physical modeling

Ubiquitous noise and non-linearities in the identification data that cannot be modeled using RC networks can be partly compensated by introduction of noise additively entering system state (process noise w) and affecting measurement (measurement noise e). Hence, the RC network gets the form of a stochastic differential equation. Model parameters can then be estimated using ML technique as

$$\theta_{ML}^* = \underset{\theta}{\operatorname{argmax}} \{\ln(L(\theta, Y_1^N | y_0))\}, \quad (31)$$

$$L(\theta, Y_1^N | y_0) = \prod_{k=1}^N \frac{\exp(-1/2 \varepsilon_k^T R_{k|k-1}^{-1} \varepsilon_k)}{(\sqrt{2\pi})^r \sqrt{\det(R_{k|k-1})}} p(y_0 | \theta) \quad (31)$$

including a prior knowledge of the system. Following the standard notation, L is a likelihood function, y_0 is the vector of initial conditions, θ is the vector of unknown parameters, $p(y_0 | \theta)$ is the conditional probability of initial conditions on parameters, ε_k are residuals and $R_{k|k-1}$ is a residual covariance matrix. It must be noted here, that the problem can be solved only in an iterative manner, when ε_k and $R_{k|k-1}$ are computed given an estimate $\hat{\theta}$ of θ . However, to compute $\hat{\theta}$, the knowledge of the noise properties must be assumed. The estimation of both parameters and covariance matrix is performed using the expectation maximization (EM) algorithm [58,59].

The above-mentioned procedure is iterative and interactive at the same time. Basically, at each step a model designer specify a tentative model structure \mathcal{M} with several unknown parameters:

$$\begin{aligned} x_t &= x_0 + \int_{t_0}^t m(\tau, x, u, p(c, \theta)) d\tau + \int_{t_0}^t \sigma(\tau, p(c, \theta)) d\beta, \\ y_{t_k} &= h(t_k, x, u, p(c, \theta)) + R(t_k, p(c, \theta)) w(t_k), \end{aligned} \quad \mathcal{M}$$

where β is the Wiener process, y is the vector of output measurements. $p(c, \theta)$ represents all the known and unknown parameters with c and θ being known constants and unknown parameters to be estimated, respectively; $w(t_k)$ is the Gaussian zero-mean white

noise with unit variance scaled arbitrary by $R(t_k, p(c, \theta))$. Note that t_k are not necessarily uniformly spaced sampling instances. The parameter optimization then takes place and terminates when the tentative model gives a statistically relevant output response. If there are no such parameter values, the model is rejected and user should specify a different model. However the user can also refine the already accepted model by adding or removing a certain component. This provides a considerable freedom to control a complexity of the model and gives user a way to find as simple model as possible. The procedure is already implemented in CTSM software.² A significant advantage of this method is that importance of adding the parameters can be tested by standard statistical tests, e.g. likelihood-ratio tests [61]. The biggest disadvantage of this method is its computational complexity and inability of handling larger amounts of data.

2.3. Comparison of the identification approaches

Finally, Table 2 summarizes the MPC applicability of above mentioned approaches from various viewpoints.

3. Co-simulation based building modeling

In this section we present a methodology how to utilize BEPST to obtain an LTI model for control. The motivation is the following:

- Data collected from the real operation of a building nearly always violate conditions under which the statistical identification techniques estimate models reliably. The main issues are the persistent excitation and the closed-loop nature of the identification data.
- A suitable identification experiment can significantly increase the model quality but such experiments can be quite expensive [11]. In addition, the more system inputs, the longer the necessary experiment time which leads to additional costs.

² Continuous-time stochastic modeling [60]

Table 2
Comparison of the identification/modeling approaches.

	Building simulation software modeling	RC modeling – tabular data driven	Deterministic and stochastic semi-physical modeling	Subspace identification	Model predictive control relevant identification
Planning data from architects and engineers need	Yes	Yes	No	No	No
Operation data need	No	No	Yes	Yes	Yes
HVAC engineering background needed	Yes	Yes	No	No	Yes
Result is achieved in defined time	Yes	Yes	No	No	No
Use of prior information about building	Yes	Yes	Yes	No	Yes
Continuous model update	No	No	Yes	No	No
MPC applicable	No	Yes	Yes	Yes	Yes
Estimation procedure computational complexity	–	–	Medium	Low	High

- In real operation, temperature signals suffer from a co-linearity. Physically, this means that the temperatures in the building are very similar in time and make the estimation problem ill-conditioned. Moreover, in case of MIMO systems, this can even lead to wrong input–output coupling in the resulting model.

It is therefore desirable to use BEPST not only for validation of the resulting controller, but for the identification data generator as well. An arbitrary experiment with no financial cost can then be performed in order to achieve a model of a desirable quality. Moreover, the complexity of the model can be controlled, e.g. by means of an examination which sensor is important for the model and which is not. If the BEPST model is a true copy of the real building then the resulting LTI model describes the real building sufficiently precisely.

3.1. Coupling control and building simulation

Even though BEPST are open for custom model adaptation, the flexibility of the tools is still limited – since they were developed and optimized for a building energy performance simulation in the first place. In order to enhance flexibility and combine simulation tools of different emphasis (such as building performance and control), a *co-simulation* becomes more and more important. Co-simulation describes the integration of different tools by runtime coupling. This allows for example to couple building energy performance simulation tools to Matlab, thus provides new possibilities to building simulation. Co-simulation fundamentals for building simulation such as coupling strategies and data transfer are described in [62].

Run-time coupling allows for example simulation assisted control. Different fields of application of building simulation tools concerning building control were defined by [63]:

- Used as an emulator, the simulation tool replaces the building and its plants. BEPST is given input by the simulation. This approach can be used for control product development, tuning control equipment, fault-detection amongst other applications.
- Used as evaluator, the building simulation tool provides a detailed building and plant model for evaluation of different control strategies, evaluation criteria being energy performance and user comfort.
- Coupling the building simulation tools to the BEPST simulation assisted control is feasible. The building simulation tool becomes part of the controller and is used to evaluate control scenarios for each control task before control actions are applied on the actual building.

Yet another field of application for co-simulation is a development and testing the MPC. Currently, many BEPST already feature interfaces to other tools:

- Trnsys allows coupling with Matlab on Windows platforms making use of Type155.
- Extensive capabilities for coupling simulation tools are provided by the Building Controls Virtual Testbed (BCVTB) which is developed by the Lawrence Berkeley National Laboratory [64]. BCVTB is a middle-ware tool that allows to couple different simulation programs for distributed simulation. Programs that can be linked via the BCVTB are EnergyPlus (EP), Matlab/Simulink, Dymola and Radiance. Data exchange with BACnet building automation systems is also featured.

3.2. Combined procedure

In this procedure, we combine benefits of both approaches, i.e. we use BEPST for identification experiments to get input–output data and then we use statistically-based algorithm to identify LTI model from the generated data.

The whole procedure of getting a building model is described in the following steps. Note that in the following discussion, we consider use of EP only, however, an arbitrary simulation tool featuring co-simulation and providing an implicit model can be used.

3.2.1. Choice of model inputs and outputs

The choice of model inputs and outputs plays an important role for the particular identification procedure. They must be chosen so that the resulting underlying physics is linear. The specific selection of the system inputs and outputs is provided in the second case study of Section 4.

3.2.2. Data preparation and system identification

High quality data needed for a system identification (SID) can be obtained as an output of the EP model provided the model is excited by specially designed inputs. The main task of the generator of EP inputs (GenEI, see Fig. 3) is a generation of sufficiently exciting input signals.

Three different kinds of input signals can be considered; pseudo-random binary signal (PRBS), sum of sinusoids (SINE) and multilevel pseudo-random signal (MPRS). Let τ_H , τ_L denote the slowest and the fastest time constants of a system, respectively. Then the frequency

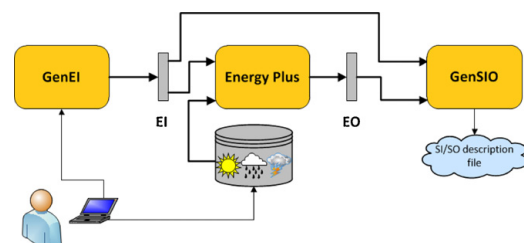

Fig. 3. Preparation of data for identification.

spectrum to cover is (ω^*, ω^*) with $\omega^* = 1/\beta\tau_H \leq \omega \leq \alpha/\tau_L = \omega^*$, where α defines how fast is a closed loop w.r.t. an open loop response. β specifies a low frequency information corresponding to a settling time. Typical values are $\alpha = 2$ and $\beta = 3$, which corresponds to 95% of the settling time [65]. In case of MPRS, an input sequence is computed by Galois fields [65] with the number of shift registers c and a length q , which defines the maximum possible multiple of harmonics to suppress. Or, in the opposite direction, let h be a maximum possible multiple of harmonics to suppress, then q must be chosen so that $q \geq 2^h - 1$ holds and c is computed from

$$\omega^* \geq \frac{2\pi}{T_s(q^n - 1)}. \quad (32)$$

The length of a signal cycle is $N_{cyc} = q^c - 1$, which (in a time domain) represents a signal of duration $T_{cyc} = N_{cyc} \cdot T_s$. The number d of signals to be generated does not need to be considered, as it is sufficient to generate a single signal and shift it $(d - 1)$ times, which guarantees good statistical properties of the generated signals [66].

Both the generated EP inputs and weather predictions are processed by EP to produce EP outputs. To have a complete set of inputs and outputs for SID, we need EP outputs, some variables from schedules (e.g. building's internal gains, equipment gains) and databases (weather predictions) that are processed by a software block written in Matlab (GenSIO, see Fig. 3).

Finally, having inputs and outputs ready, a SID algorithm is performed to obtain a linear time-invariant model.

4. Case studies

We will discuss here two examples of buildings with completely different structure and complexity. Both of them will demonstrate the properties of the co-simulation based procedure from Section 3. The first one deals with a large office building that is modeled using EP and due to the model complexity, 4SID identification technique is the only option to get LTI model, whilst the second example is an artificial building constructed in Trnsys environment, where the performance of all identification approaches from Section 2 but 4SID is investigated.

For evaluation of a model quality we will use a normalized root mean square error (NRMSE) fitness value defined as:

$$NRMSE_{fit} = \left(1 - \frac{\|y_k - \hat{y}_k\|_2}{\|y_k - E(y_k)\|_2} \right) 100 \%, \quad (33)$$

where E stands for the expected value operator.

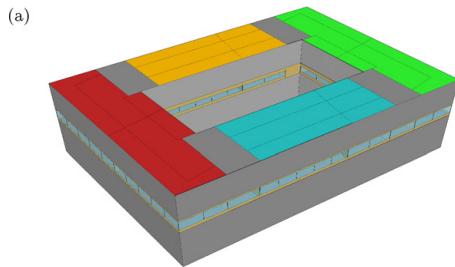

4.1. Example I: a large office building in Munich

4.1.1. Building description

The building under investigation is a large office building in Munich (20 000 m², six above-ground floors, see Fig. 4(a) and (b)). The objective of the identification is the 3rd floor with an area of approximately 2800 m². Based on a usage, a façade orientation and a HVAC supply, the floor can be divided into 24 mutually interconnected zones. The façade of the building has a window-to-wall ratio of approx. 70%. Façades to the atrium have a glazing ratio of approx. 50%. Roughly 50% of the windows have interior blinds, remaining blinds are in-between-glass blinds of double windows.

The building automation system contains several actuators: individually controlled convectors, 24 independently controlled radiant ceiling panels for cooling and heating, two air handling units (AHU) for control of the ventilation, and Venetian blinds for all windows in all zones. Energy supply, i.e. hot and chilled water supply for the entire building, is provided by a central heating and a cooling plant, which is located partly in the basement and partly on the roof. District heating is used for the building's heat supply. Chilled water is provided locally by mechanical chillers. We will now follow the steps from Section 3.

4.1.2. Building modeling

Choice of modeling strategy, inputs and outputs. Following the discussion in Section 3 we selected the heat fluxes affecting zone temperatures for system inputs and temperatures and illuminances for system outputs to obtain an LTI model. The selection resulted in 288 inputs and 48 outputs lumped into the variable categories as described in Table 3. Note that some inputs are common for multiple zones, while others are unique for respective zones. Signals, that are common for multiple zones are marked by 'No' in the column 'Zone relevant' of Table 3. Signals marked by 'Yes' are unique for each single zone and therefore each category has as many signals as zones (E.g. there are 16 convectors for 24 zones, therefore variable category Q_{conv} contains 16 signals.). Moreover, all the variables are inputs/outputs/disturbances of the LTI model (model produced by SID). These are not necessarily the same as those of EP (remember a use of GenSIO from Section 3.2.2), which is indicated in the column EP equivalent.

Excitation signals. The fastest and the slowest time constants are 4 h and 20 days, respectively. The minimum necessary length of the experiment as well as a suitable sampling time and additional settings are obtained from the aforementioned technique (see Section 3.2.2) for the excitation signal generation. Apart from the frequency properties there exist further requirements on the properties of the input signal such as minimum and maximum values, a maximum possible step or a mutual exclusivity of some signals.



Fig. 4. Office building in Munich. (a) 3D simulation model: investigated zones are on the third floor, other floors are grayed out. The zone layout is shown on top of the model for clarity. The zones of the same sub-system are colored alike. Core areas are gray. (b) A photo of the building shortly before opening.

Table 3
Notation of the variables used for system identification.

ID	Variable category	Type	Zone relevant	EP equivalent
Q _{conv}	Convector heating rate	Input	Yes	Same quantity, power can be arbitrarily set within limits
ZCPCR	Zone ceiling panel cooling rate	Input	Yes	Supply water temperature and mass flow rate through plumbing can be adjusted. Together with return water temperature, they stand for heat flux of radiant ceiling
ZCPHR	Zone ceiling panel heating rate	Input	Yes	Same as ZCPCR
LG	Lighting gains	Input	Yes	Same quantity, power can be arbitrarily set within limits
NRF	Net radiation flux	Disturbance	Yes	Partly by means of blinds control
FP	Fan power	Input	Yes	Air flow rate (which is either 55 or 0 m ³ /h) and supply air temperature. Together with return air temperature, they stand for heat flux of fans.
ODBT	Outdoor dry bulb temperature	Disturbance	No	Same quantity
EG	Equipment gains	Disturbance	Yes	Same quantity
OG	Occupancy gains	Disturbance	Yes	Same quantity
ZT	Zone temperature	Output	Yes	Same quantity
ZI	Zone interior illuminance	Output	Yes	Same quantity

After analysis of a frequency response of the system, PRBS was chosen as the most convenient excitation input signal from the investigated group. Its advantage compared to SINE input signal is that it covers the whole frequency interval (frequency spectrum of SINE signal is not continuous) and compared to MPRS is the speed of its generation (milliseconds in case of PRBS, minutes or even hours depending on the number of inputs and signal length in case of MPRS).

In case of unknown processes and non-linearities in the system, the best choice is to use PRBS for the first shoot and then analyze system frequency response because MPRS has clearly delimited frequency spectrum and some of system modes might not be properly excited.

Analysis of the linearity of EP model. In Section 3.2.2 we have discussed an importance of a linearity of the underlying physics of the process to allow the use of the 4SID algorithm. Hence we need to verify linearity of the data produced by EP, which can be performed according to a definition, i.e.

$$\alpha f(x_1) + \beta f(x_2) = f(\alpha x_1 + \beta x_2). \quad (34)$$

This means, that independent inputs (e.g. convectors in Fig. 5(a) and (b) lower figures, and equipment and lightning gains Fig. 6(a) lower figure) are fed into EP and the sum of corresponding outputs is compared to the response of EP to the sum of the same inputs. The results can be seen in Fig. 5(c) and (d) for convectors, equipment and lightning gains, respectively. The errors between the responses are summarized in Table 4. The growing error in case of a multiple step in input signals can be explained as follows. Linearity tests were intentionally performed at two different outside temperatures, namely 15 °C and 20 °C. The actual zone temperatures are a bit different due to the heat flux (from/to measured zones), i.e. $Q_{ss} - Q_{cool}(T_z) = Q_{EP}$. Q_{ss} denotes here the heat flux corresponding to the designed input (e.g. convectors), $Q_{cool}(T_z)$ is a flux altering (an actual size depends on the temperature difference between outside and zone temperatures) the requested value and Q_{EP} is a real value of the flux affecting EP. When summing-up two signals of a different step size, there is a different alternation by $Q_{cool}(T_z)$, hence a small difference between the sum of responses and a response of

Table 4
Temperature linearity error.

Errors in %	EG	LG	Q _{conv}	
			15 °C outside	20 °C outside
2nd step	3.9	2.1	4.4	5.2
3rd step	3.3	1.0	3.4	5.0

the sums. Nevertheless, it can be concluded, that EP response on selected inputs is indeed linear.

Settings of the identification procedure. Final step is the choice of parameters for the SID, namely identification algorithm, desired model order and size of the Hankel matrices.

- 1. Identification algorithm:** There are several algorithms covered by 4SID, which differ in, for instance, applicability, numerical stability and computational demands [21]. For our case, N4SID was selected.
- 2. Desired model order:** Although the order selection has already been implemented in N4SID, an insight into a building physics can help. A physically based order selection leads to a 2nd–3rd order dynamics per output temperature [57] leading thus to the order between 48 and 72 for 24 zones. After employing N4SID algorithm and validation tests, 72th order model (order selection according to an algorithm Eq. (8)) turned out to be indeed a good choice, considering both its simplicity and sufficient precision.
- 3. Size of Hankel matrices** is given by the number i of block rows, Section 2.2.1, $i > n$, where n is a system order to identify [21]. Essentially, i means how far into the past/future of the measured data is searched. It may therefore seem that bigger i leads to a better result. However, one should not forget, that the size of the system matrices grows considerably with the system size and i must be therefore a trade-off between computation difficulties and the size of a “memory window”.

Several values of i were examined experimentally and the results for step responses to several inputs for $i = 24, 30, 36$ and 40 are depicted in Fig. 7. All step responses recorded satisfactory results as far as reliable dynamics, a sign of the effect and nominal value is of concern. The increase of i leads only to DC-gains change. Next, the measured step responses were analyzed. It turned out, that with bigger i the model step responses approach to the measured step responses (see Fig. 8). Because of the computational limitations, the $i = 40$ has been selected as a suitable choice for the size of Hankel matrices.

Prediction properties. The good prediction properties of the identified model are crucial for predictive controller. For comparison of the predictions for various prediction horizon refer to Figs. 9 and 10. It can be seen, that the model has satisfactory prediction properties even for larger horizons.

4.2. Example II: artificial building modeled in Trnsys

In the second example, we will consider a small building modeled in Trnsys environment. As mentioned before, the

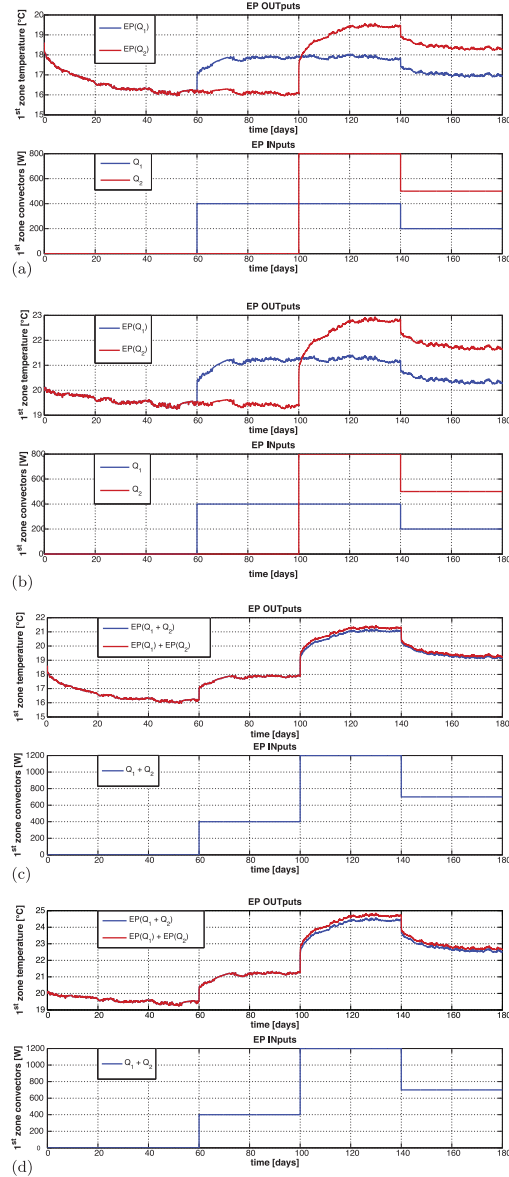

Fig. 5. Convectors: test of linearity of the EP model. (a) Two convectors: input signals at outside temperature 15 °C and the EP model response. (b) Two convectors: input signals at outside temperature 20 °C and the EP model response. (c) Sum of two convectors: input signal at outside temperature 15 °C and EP model response (response of sum and sum of responses). (d) Sum of two convectors: input signal at outside temperature 20 °C and EP model response (response of sum and sum of responses).

current system identification techniques from Section 2 can be used.

4.2.1. Building description

A building, schematically outlined in Fig. 11, was constructed in Trnsys environment. It is a medium weight office building with

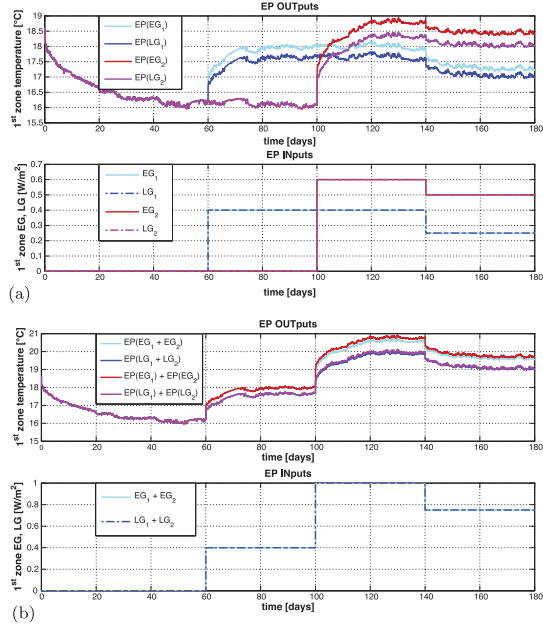

Fig. 6. Equipment and lighting gains: test of the EP model linearity. (a) Two convectors: input signals at outside temperature 15 °C and the EP model response. (b) Sum of signals: input signals at outside temperature 20 °C.

two zones (5 m × 5 m × 3 m) separated by a concrete wall (involving the transient properties between zones). South oriented walls of the zones include a window (3.75 m²). The HVAC system used in the building is TABS [67]. Technically, a set of pipes is placed in the ceiling and distributes supply water which then performs a thermal exchange with a concrete core. Each zone has a unique heating circuit with a constant mass flow rate of the supply water leaving thus a supply water temperature the only manipulated variable. This control strategy was chosen to mimic a real-life application [12], where there are no valves, thus no possibility of control the fluxes.

We employed several Trnsys components such as (i) Type56 for a construction of the building, (ii) Type15 for outside environmental conditions (involving ambient temperature, outside air relative humidity and solar characteristic) with year weather profile corresponding to Prague, Czech Republic, (iii) Type155 to establish a link between Trnsys and Matlab.

The communication link was used to generate identification data in order to excite the system properly. Based on the previous discussion, PRBS was used as an excitation input signal. Time-step of the simulation was set to $T_s = 0.25$ h which guarantees a proper convergence of Trnsys internal algorithms and is also suitable for a description of important building dynamics.

4.2.2. Building modeling

Choice of modeling strategy, inputs and outputs. The model built in Trnsys has 18 states and 12 inputs (manipulated variables and disturbances). We applied an iterative procedure for selection of a minimum input and state sets [42]. The procedure iteratively selects only those inputs and states which brings statistically significant information to the model. Finally, we obtained 4 out of original 12 inputs (8 disturbances were proven not be significant),

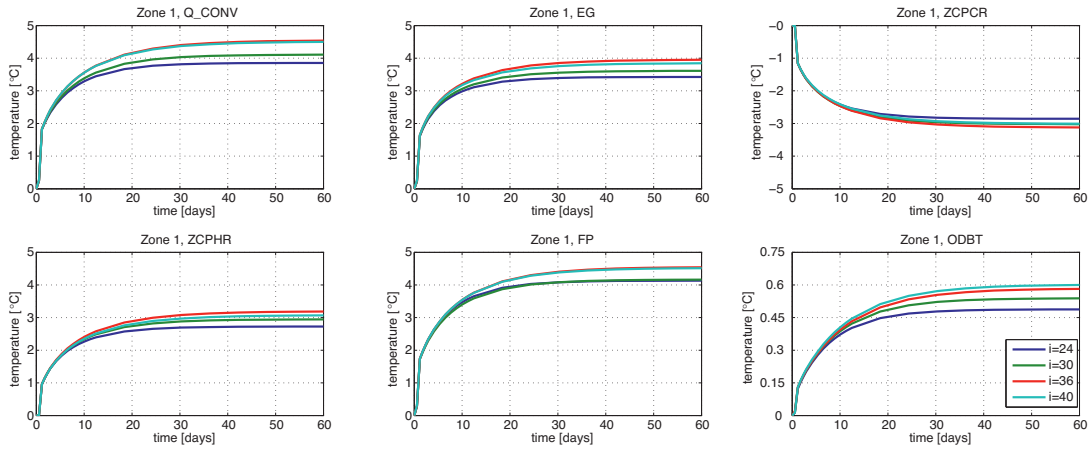

Fig. 7. Step responses of several inputs in zone 1 for different is. Vertical axes are particular contributions to zone temperatures.

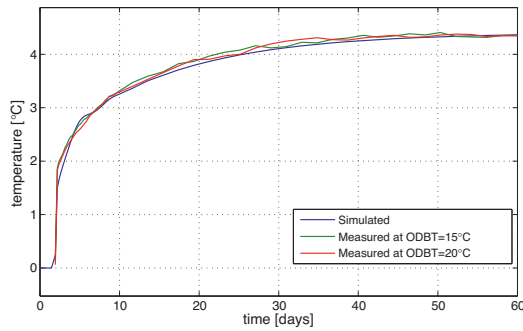

Fig. 8. Comparison of measured and simulated step responses from convectors.

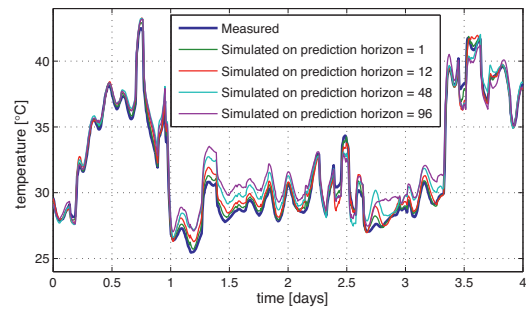

Fig. 10. Part of model outputs.

namely T_{sw1} , T_{sw2} , T_o and \dot{Q} and 6 out of original 18 states, namely T_{c1} , T_{wall1} , T_{z1} , T_{c2} , T_{wall2} and T_{z2} with a meaning described in Table 5. Note that the table presents only those states that are depicted in Fig. 11.

Identification procedures used. We are now ready to investigate the applicability of the methods from Section 2. As the investigated building is a small, more computationally demanding identification techniques can be used.

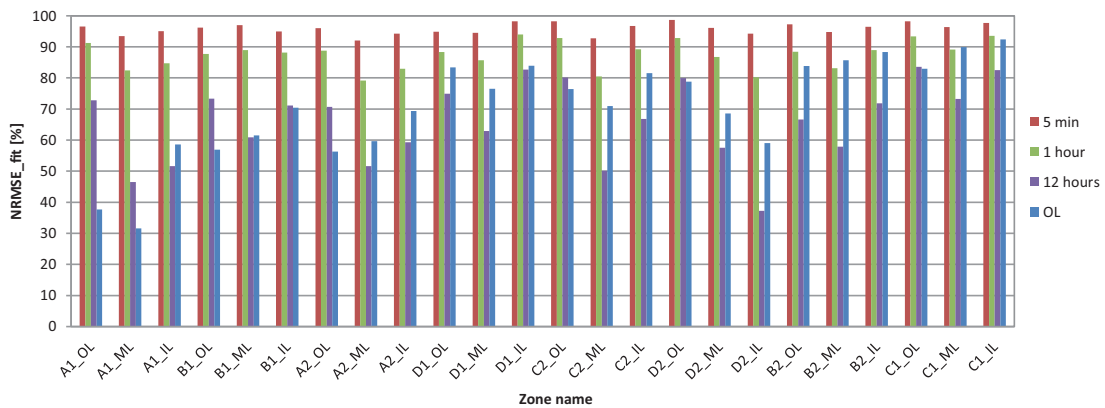

Fig. 9. $NRMSE_{fit}$ for all zones for different k -step ahead predictions.

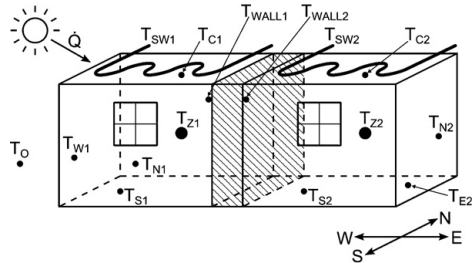

Fig. 11. A scheme of the modeled building.

Table 5

System states, inputs and measured disturbances.

Notation	Description
(a) System inputs and measured disturbances	
T_{sw1}	Supply water temperature, zone 1
T_{sw2}	Supply water temperature, zone 2
T_o	Ambient temperature
\dot{Q}	Solar radiation
(b) System states	
T_{c1}	Ceiling core temperature, zone 1
T_{wall1}	Core temperature of common wall, zone 1
T_{s1}	Core temperature on south side, inside, zone 1
T_{w1}	Core temperature on west side, inside, zone 1
T_{n1}	Core temperature on north side, inside, zone 1
T_{z1}	Zone temperature, zone 1
T_{c2}	Ceiling core temperature, zone 2
T_{wall2}	Core temperature of common wall, zone 2
T_{s2}	Core temperature on south side, inside, zone 2
T_{e2}	Core temperature on east side, inside, zone 2
T_{n2}	Core temperature on north side, inside, zone 2
T_{z2}	Zone temperature, zone 2

For MRI and DSPM, we consider a model of the following form

$$y(z) = G(z)u(z) + H(z)e(z), \quad (35)$$

with $G(z)$ and $H(z)$ transfer functions corresponding to a deterministic and a stochastic³ part of the system. A state-space model will be used for case of PSPM as:

$$dx_t = (A(\theta)x_t + B(\theta)u_t)dt + \sigma(\theta)d\omega_t, \quad (36)$$

$$y_t = C(\theta)x_t + D(\theta)u_t + e_t, \quad (37)$$

where $\theta \in \Theta \subset \mathbb{R}^p$ is the vector of parameters, ω_t is the n -dimensional Wiener process and $e_t \sim \mathcal{N}(0, S(\theta))$ is a white zero-mean Gaussian noise and $A(\bullet)$, $B(\bullet)$, $\sigma(\bullet)$, $C(\bullet)$, $D(\bullet)$ and $S(\bullet)$ are appropriate system parametric matrices.

Prediction properties. The performance of the respective methods is evaluated using $NRMSE_{fit}$ and is summarized in Fig. 12. To show the properties of the identification methods, Fig. 12 depicts results which correspond only to the deterministic transfer function. A comparison of measured and predicted outputs (for deterministic transfer function only) obtained from models of different approaches for 15 steps-ahead prediction is depicted in Fig. 13. These results are presented for one zone, however, they are almost identical to the other zone which is not presented due to space reasons. Note that 4 step-ahead predictions for all methods recorded $NRMSE_{fit}$ over 96% even without stochastic part which can be considered as excellent. The growing error with larger horizons

³ Note that $H(z)$ includes non-linearities of a detailed Trnsys model which cannot be described by a linearized model.

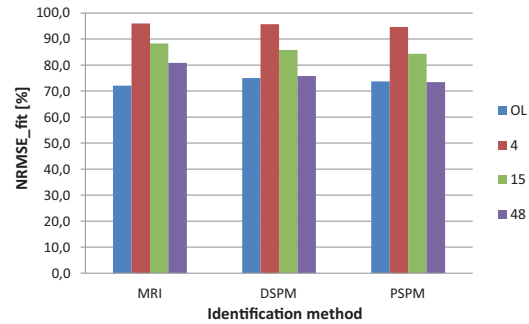

Fig. 12. $NRMSE_{fit}$ for different methods (MRI, DSPM, PSPM) and different prediction horizons (4, 15, 48 steps and open loop, each step is 15 min).

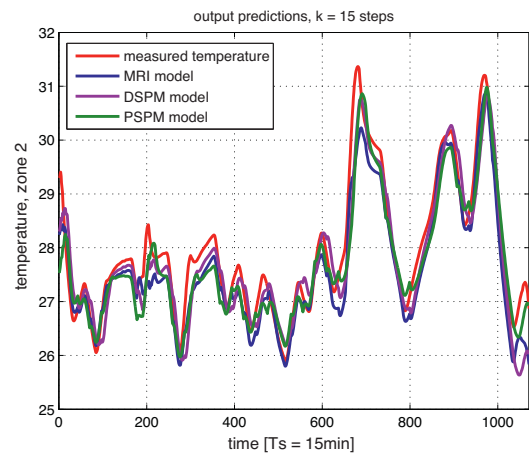

Fig. 13. Temperature predictions using different methods and 15 step-ahead prediction horizon.

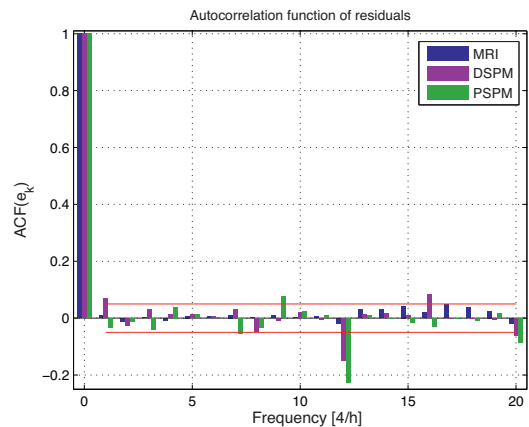

Fig. 14. Autocorrelation function of residuals of predicted output. The red horizontal lines correspond to 5% significance level. (For interpretation of the references to color in this figure legend, the reader is referred to the web version of the article.)

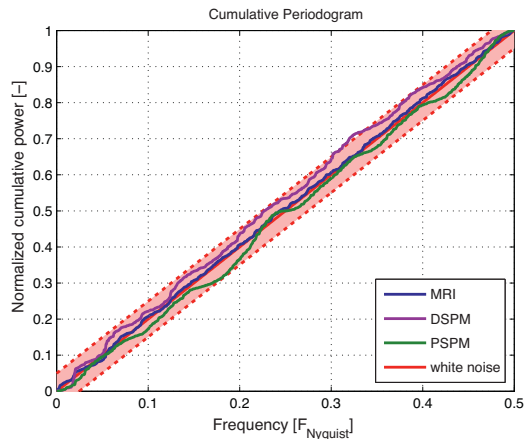

Fig. 15. Cumulative periodogram of residuals of a predicted output. The red dotted lines correspond to 5% significance level. (For interpretation of the references to color in this figure legend, the reader is referred to the web version of the article.)

is caused by non-linearities of the underlying physics, which are lumped in a stochastic part ($H(z)$).

Validation of models. To evaluate the validity of the models we have used several tests applied to model residuals, namely (i) test of Autoregressive (AR) process order, for details refer to [68,69] and (ii) tests using partial autocorrelation function (PACF) and cumulative periodogram [70].

All the tests confirmed the whiteness of the residuals for all three identification approaches, for visual results refer to Figs. 14 and 15. It can be seen, that the residuals are well within the confidence intervals corresponding to the 5% significance level.

5. Concluding remarks

Apart from a detailed overview of modeling approaches and algorithms suitable for a predictive control, two case studies were presented. The first was a real-life example of a large office building in Munich where a new procedure combining an implicit model built in EnergyPlus and a subsequent statistical identification, namely 4SID algorithm, was presented. For large buildings with a complex structure, the only viable option seems to be statistically-based algorithms which are inherently capable of treating MIMO systems. The biggest disadvantage of 4SID is that it does not preserve a physical structure during modeling phase, which causes deteriorating predictions for the larger horizon.

The second example of an artificial building modeled in Trnsys demonstrated that use of a number of identification approaches (MRI, DSPM, PSPM) led to the very similar results. These methods make use of a known system structure and estimate system parameters. This property ensures appropriate prediction properties even for longer prediction horizon. On the other hand, time demands and a computational complexity become the issue for these methods in two ways. (i) With a growing complexity of a process (building), a description becomes difficult to follow pointing thus to 4SID as the only suitable candidate. (ii) Use of a probabilistic semi-physical modeling and MRIs for large datasets and/or complex systems becomes computationally infeasible.

Therefore, the methods that make use of a physical description of a system should be used primarily for buildings with simpler structure.

Note that not all the BEPST as introduced in Section 2.1 can be used in co-simulation as not all of them possess the capability of the co-simulation. Building modeling tools Trnsys and EnergyPlus were used to mimic the behavior of a modeled building. All the presented models are in explicit form with reasonable prediction properties suitable for predictive control.

Acknowledgment

The project has been supported by the grant of the Grant Agency of Czech Republic (GACR) no. P103/12/1187.

References

- [1] L. Pérez-Lombard, J. Ortiz, C. Pout, A review on buildings energy consumption information, *Energy and Buildings* 40 (3) (2008) 394–398, <http://dx.doi.org/10.1016/j.enbuild.2007.03.007>.
- [2] Y. Zhu, Multivariable process identification for MPC: the asymptotic method and its applications, *Journal of Process Control* 8 (2) (1998) 101–115.
- [3] B. Tashtoush, M. Molhim, M. Al-Rousan, Dynamic model of an HVAC system for control analysis, *Energy* 30 (10) (2005) 1729–1745, <http://dx.doi.org/10.1016/j.energy.2004.10.004>.
- [4] M. Gwerder, D. Gyalistras, F. Oldewurtel, B. Lehmann, K. Wirth, V. Stauch, J. Tödtli, C. Tödtli, Potential assessment of rule-based control for integrated room automation, in: 10th REHVA World Congress Clima, 2010, pp. 9–12.
- [5] Y. Ma, A. Kelman, A. Daly, F. Borrelli, Predictive control for energy efficient buildings with thermal storage: modeling stimulation and experiments, *Control Systems IEEE* 32 (1) (2012) 44–64, <http://dx.doi.org/10.1109/MCS.2011.2172532>.
- [6] C. Verhelst, F. Logist, J.V. Impe, L. Helsen, Study of the optimal control problem formulation for modulating air-to-water heat pumps connected to a residential floor heating system, *Energy and Buildings* 45 (0) (2012) 43–53, <http://dx.doi.org/10.1016/j.enbuild.2011.10.015>.
- [7] J. Ma, S. Qin, B. Li, T. Salisbury, Economic model predictive control for building energy systems, in: Innovative Smart Grid Technologies (ISGT), 2011 IEEE PES, doi:10.1109/ISGT.2011.5759140, 2011, pp. 1–6.
- [8] J. Cigler, S. Privara, Z. Váňa, E. Žáčková, L. Ferkl, Optimization of predicted mean vote index within model predictive control framework: computationally tractable solution, *Energy and Buildings*, <http://dx.doi.org/10.1016/j.enbuild.2012.05.022>.
- [9] R. Freire, G. Oliveira, N. Mendes, Predictive controllers for thermal comfort optimization and energy savings, *Energy and Buildings* 40 (7) (2008) 1353–1365.
- [10] G.E. Kelly, Control system simulation in north America, *Energy and Buildings* 10 (3) (1988) 193–202, [http://dx.doi.org/10.1016/0378-7788\(88\)90005-9](http://dx.doi.org/10.1016/0378-7788(88)90005-9).
- [11] J. Široký, F. Oldewurtel, J. Cigler, S. Privara, Experimental analysis of model predictive control for an energy efficient building heating system, *Applied Energy* 88 (9) (2011) 3079–3087, <http://dx.doi.org/10.1016/j.apenergy.2011.03.009>.
- [12] S. Privara, J. Široký, L. Ferkl, J. Cigler, Model predictive control of a building heating system: the first experience, *Energy and Buildings* 43 (2–3) (2011) 564–572, <http://dx.doi.org/10.1016/j.enbuild.2010.10.022>.
- [13] Y. Zhu, *Multivariable System Identification for Process Control*, Elsevier, 2001.
- [14] H. Hjalmarsson, System identification of complex and structured systems, *European Journal of Control* 15 (3–4) (2009) 275–310.
- [15] R. Gopaluni, R. Patwardhan, S. Shah, MPC relevant identification-tuning the noise model, *Journal of Process Control* 14 (6) (2004) 699–714.
- [16] Z. Váňa, H. Preisig, System identification in frequency domain using wavelets: conceptual remarks, *Systems & Control Letters* 61 (10) (2012) 1041–1051.
- [17] L. Thermal Energy System Specialists, Transient System Simulation Tool, <http://www.trnsys.com>, 2011.
- [18] EnergyPlus Energy Simulation Software, U.S. Department of Energy, <http://apps1.eere.energy.gov/buildings/energyplus/>, 2011.
- [19] Esp-r, <http://www.esru.strath.ac.uk/Programs/ESP-r.htm>, 2011.
- [20] B. Coffey, F. Haghghat, E. Morofsky, E. Kutrowski, A software framework for model predictive control with genopt, *Energy and Buildings* 42 (7) (2010) 1084–1092, <http://dx.doi.org/10.1016/j.enbuild.2010.01.022>.
- [21] P. Van Overschee, B. De Moor, *Subspace Identification for Linear Systems*, Kluwer Academic Publishers, Nowell, MA, 1999.
- [22] E. Toffoli, G. Baldan, G. Albertin, L. Schenato, A. Chiuso, A. Beghi, Proceedings of IFAC World Congress, vol. 17, COEX, South Korea, 2007, pp. 2196–2201, <http://dx.doi.org/10.3182/20080706-5-KR-1001.01497>.
- [23] L. Ferkl, J. Široký, Ceiling radiant cooling: comparison of armax and subspace identification modelling methods, *Building and Environment* 45 (1) (2010) 205–212, <http://dx.doi.org/10.1016/j.buildenv.2009.06.004>.
- [24] J. Cigler, S. Privara, Subspace identification and model predictive control for buildings, in: The 11th International Conference on Control, Automation, Robotics and Vision – ICARCV 2010, 2010, pp. 750–755.
- [25] S. Privara, Z. Váňa, D. Gyalistras, J. Cigler, C. Sagerschnig, M. Morari, L. Ferkl, Modeling and identification of a large multi-zone office building, in: 2011 IEEE International Conference on Control Applications (CCA), 2011, pp. 55–60, <http://dx.doi.org/10.1109/CCA.2011.6044402>.
- [26] L. Ljung, *System Identification: Theory for User*, Prentice-Hall, Inc., Upper Saddle River, New Jersey, USA, 1999.

- [27] S. Wu, J.-Q. Sun, A physics-based linear parametric model of room temperature in office buildings, *Building and Environment* 50 (0) (2012) 1–9, <http://dx.doi.org/10.1016/j.buildenv.2011.10.005>.
- [28] G. Mustafaraj, J. Chen, G. Lowry, Development of room temperature and relative humidity linear parametric models for an open office using BMS data, *Energy and Buildings* 42 (3) (2010) 348–356, <http://dx.doi.org/10.1016/j.enbuild.2009.10.001>.
- [29] J.C.-M. Yiu, S. Wang, Multiple armax modeling scheme for forecasting air conditioning system performance, *Energy Conversion and Management* 48 (8) (2007) 2276–2285, <http://dx.doi.org/10.1016/j.enconman.2007.03.018>.
- [30] D. Shook, C. Mohtadi, S. Shah, A control-relevant identification strategy for GPC, *IEEE Transactions on Automatic Control* 37 (7) (2002) 975–980.
- [31] D. Laurí, M. Martínez, J. Salcedo, J. Sanchis, PIs-based model predictive control relevant identification: PIs-ph algorithm, *Chemometrics and Intelligent Laboratory Systems* 100 (2) (2010) 118–126, <http://dx.doi.org/10.1016/j.chemolab.2009.11.008>.
- [32] R. Gopaluni, R. Patwardhan, S. Shah, MPC relevant identification-tuning the noise model, *Journal of Process Control* 14 (6) (2004) 699–714.
- [33] E. Žáčková, S. Privara, Z. Váňa, Model predictive control relevant identification using partial least squares for building modeling, in: *IEEE Australian Control Conference (AUCC)*, 2011, pp. 422–427.
- [34] D. Gyalistras, M. Gwerder, Use of weather and occupancy forecasts for optimal building climate control (opticontrol): two years progress report, Tech. Rep., Terrestrial Systems Ecology ETH Zurich, Switzerland and Building Technologies Division, Siemens Switzerland Ltd., Zug, Switzerland, 2010.
- [35] M. Jimenez, H. Madsen, K. Andersen, Identification of the main thermal characteristics of building components using MATLAB, *Building and Environment* 43 (2) (2008) 170–180.
- [36] L. Ljung, *MATLAB: System Identification Toolbox: User's Guide Version 4*, The Mathworks, 1995.
- [37] S. Wang, X. Xu, Simplified building model for transient thermal performance estimation using GA-based parameter identification, *International Journal of Thermal Sciences* 45 (4) (2006) 419–432.
- [38] M. Gwerder, B. Lehmann, J. Tödtli, V. Dorer, F. Renggli, Control of thermally-activated building systems (TABS), *Applied Energy* 85 (7) (2008) 565–581.
- [39] T. Bohlin, S. Graebe, Issues in nonlinear stochastic grey box identification, *International Journal of Adaptive Control and Signal Processing* 9 (6) (2007) 465–490.
- [40] P. Bacher, H. Madsen, Identifying suitable models for the heat dynamics of buildings, *Energy and Buildings* 43 (7) (2011) 1511–1522.
- [41] K. Andersen, H. Madsen, L. Hansen, Modelling the heat dynamics of a building using stochastic differential equations, *Energy and Buildings* 31 (1) (2000) 13–24.
- [42] S. Privara, Z. Váňa, E. Žáčková, J. Cigler, Building modeling: selection of the most appropriate model for predictive control, *Energy and Buildings* (0) (2012), <http://dx.doi.org/10.1016/j.enbuild.2012.08.040>
- [43] P. Bannister, The ABGR validation protocol for computer simulations, in: *Proceedings of Conference Building Simulation*, vol. 5, Citeseer, 2005, pp. 33–40.
- [44] P. Van Overschee, B. De Moor, N4SID: Subspace algorithms for the identification of combined deterministic–stochastic systems, *Automatica* 30 (1) (1994) 75–93.
- [45] G. Van Der Veer, J. Wingerden, M. Van Verhaegen, Closed-loop MOESP subspace model identification with parametrisable disturbances, in: *49th IEEE Conference on Decision and Control*, Atlanta, 2010, pp. 2813–2818.
- [46] M. Poulliquen, O. Gehan, E. Pigeon, An indirect closed loop subspace identification method, in: *49th IEEE Conference on Decision and Control*, No. 3, Atlanta, 2010, pp. 4417–4422.
- [47] D. Miller, R. Callafon, Subspace identification using dynamic invariance in shifted time-domain data, in: *49th IEEE Conference on Decision and Control*, No. 0, Atlanta, 2010, pp. 2035–2040.
- [48] C. Lyzell, Initialization methods for system identification, Licentiate thesis no. 1426, Department of Electrical Engineering, Linköping University, SE-581 83 Linköping, Sweden, November 2009.
- [49] Huang Gongsheng, Model predictive control of vav zone thermal systems concerning bi-linearity and gain nonlinearity, *Control Engineering Practice* 19 (7) (2011) 700–710, <http://dx.doi.org/10.1016/j.conengprac.2011.03.005>.
- [50] V. Verdult, M. Verhaegen, Subspace identification of multivariable linear parameter-varying systems, *Automatica* 38 (5) (2002) 805–814.
- [51] J. van Wingerden, M. Verhaegen, Subspace identification of bilinear and LPV systems for open-and closed-loop data, *Automatica* 45 (2) (2009) 372–381.
- [52] V. Verdult, M. Verhaegen, A kernel method for subspace identification of multivariable bilinear systems, in: *Proceedings of the 42nd IEEE Conference on Decision and Control*, 2003, vol. 4, 2004, pp. 3972–3977.
- [53] R. Gopaluni, R. Patwardhan, S. Shah, Bias distribution in MPC relevant identification, in: *Proceedings of IFAC World Congress*, Barcelona, Citeseer, 2002, pp. 2196–2201.
- [54] D. Shook, C. Mohtadi, S. Shah, Identification for long-range predictive control theory and applications, in: *IEE Proceedings D* 138 (1), 1991, pp. 75–84.
- [55] D. Shook, C. Mohtadi, S. Shah, A control-relevant identification strategy for GPC, *IEEE Transactions on Automatic Control* 37 (7) (2002) 975–980.
- [56] M. Gevers, A decade of progress in iterative process control design: from theory to practice, *Journal of process control* 12 (4) (2002) 519–531.
- [57] M. Barták, Úvod do přenosových jevů pro inteligentní budovy, Czech Republic, CTU Prague, Prague, 2010.
- [58] T. Louis, Finding the observed information matrix when using the EM algorithm, *Journal of the Royal Statistical Society. Series B (Methodological)* (1982) 226–233.
- [59] G. McLachlan, T. Krishnan, *The EM Algorithm and Extensions*, vol. 382, John Wiley and Sons, 2008.
- [60] N. Kristensen, H. Madsen, S. Jørgensen, Parameter estimation in stochastic grey-box models, *Automatica* 40 (2) (2004) 225–237.
- [61] C. Gourieroux, A. Holly, A. Monfort, Likelihood ratio test wald test and kuhn-tucker test in linear models with inequality constraints on the regression parameters, *Econometrica Journal of the Econometric Society* (1982) 63–80.
- [62] M. Trčka, J. Hensen, M. Wetter, Co-simulation of innovative integrated HVAC systems in buildings, *Journal of Building Performance Simulation* 2 (3) (2009) 209–230.
- [63] J. Clarke, J. Cockroft, S. Conner, J. Hand, N. Kelly, R. Moore, T. O'Brien, P. Strachan, Control in building energy management systems: the role of simulation, in: *Proc. 7th International IBPSA Conf.*, Rio de Janeiro, Brazil, 2001, pp. 99–108.
- [64] M. Wetter, Co-simulation of building energy and control systems with the building controls virtual test bed, *Journal of Building Performance Simulation* 4 (3) (2011) 185–203, <http://dx.doi.org/10.1080/19401493.2010.518631>.
- [65] M. Braun, D. Rivera, A. Stenman, W. Foslien, C. Hrenya, Multi-level pseudo-random signal design and “model-on-demand” estimation applied to nonlinear identification of a rtp wafer reactor, in: *Proceedings of the American Control Conference*, vol. 3, 1999, pp. 1573–1577, <http://dx.doi.org/10.1109/ACC.1999.786090>.
- [66] S. Gaikwad, D. Rivera, Control-relevant Input Signal Design for Multivariable System Identification: Application to High-purity Distillation, 1996.
- [67] B. Lehmann, V. Dorer, M. Koschenz, Application range of thermally activated building systems tabs, *Energy and Buildings* 39 (5) (2007) 593–598.
- [68] T. Pukkila, P. Krishnaiah, On the use of autoregressive order determination criteria in multivariate white noise tests, *IEEE Transactions on Acoustics Speech and Signal Processing* 36 (9) (1988) 1396–1403, <http://dx.doi.org/10.1109/29.90367>.
- [69] P. Matisko, V. Havlena, Optimality Tests and Adaptive Kalman Filter, *16th IFAC Symposium on System Identification* 16 (1) (2012) 1523–1528, <http://dx.doi.org/10.3182/20120711-3-BE-2027.00011>.
- [70] G. Box, G. Jenkins, G. Reinsel, *Time Series Analysis*, Holden-day, San Francisco, 1970.

International Journal of Modelling, Identification and Control paper entitled *Incorporation of System Steady State Properties into Subspace Identification Algorithm* offers the incorporation of the PI into the 4SID algorithm. There are two kinds of PI provided, namely the known static gain and existence/non-existence of the system matrix D. This kind of PI is sometimes able to improve the statistical identification procedure which would otherwise fail due to noisy data with low information content.

The performance of the algorithm is shown on a case study and compared to the current methods, where the model is used for an MPC control of a large building heating system.

The percentage share of the author on the result according to VVVS is 40%.

Incorporation of system steady state properties into subspace identification algorithm

Samuel Prívvara*, Jiří Cigler, Zdeněk Váňa and Lukáš Ferkl

Department of Control Engineering,
Faculty of Electrical Engineering,
Czech Technical University in Prague,
Karlovo náměstí 13, Czech Republic
E-mail: samuel.privara@fel.cvut.cz
E-mail: jiri.cigler@fel.cvut.cz
E-mail: zdenek.vana@fel.cvut.cz
E-mail: lukas.ferkl@fel.cvut.cz

*Corresponding author

Abstract: Most of the industrial applications are multiple-input multiple-output (MIMO) systems that can be identified using the knowledge of the system's physics or from measured data employing statistical methods. Currently, there is the only class of statistical identification methods capable of handling the issue of the vast MIMO systems – subspace identification methods. These methods, however, as all the statistical methods, need data of a certain quality, i.e., excitation of the corresponding order, no data corruption, etc. Nevertheless, combination of the statistical methods and a physical knowledge of the system could significantly improve system identification. This paper presents a new algorithm which provides remedy to the insufficient data quality of a certain kind through incorporation of the prior information, namely a known static gain and an input-output feed-through. The presented algorithm naturally extends classical subspace identification algorithms, that is, it adds extra equations into the computation of the system matrices. The performance of the algorithm is shown on a case study and compared to the current methods, where the model is used for an MPC control of a large building heating system.

Keywords: subspace methods; incorporation of prior information; steady state properties.

Reference to this paper should be made as follows: Prívvara, S., Cigler, J., Váňa, Z. and Ferkl, L. (2012) 'Incorporation of system steady state properties into subspace identification algorithm', *Int. J. Modelling, Identification and Control*, Vol. 16, No. 2, pp.159–167.

Biographical notes: Samuel Prívvara received his BSc and MSc both from Czech Technical University in Prague (CTU), Faculty of Electrical Engineering, Department of Control Engineering in 2007 and 2010, respectively. Currently, he is a PhD student at the CTU. His research focuses on control-oriented system identification, statistical identification methods and incorporation of prior information into the identification algorithms such as state space subspace identification methods. His thesis is oriented on modelling of the large systems such office buildings and their subsequent predictive control. In 2010, he spent six months at ETH Zurich, in the group of Professor Manfred Morari performing research in modelling, identification and control of the complex office buildings.

Jiří Cigler received his MSc in Electrical Engineering in 2009 from the CTU in Prague in study programme cybernetics and measurement. Currently, he is researcher and PhD student at the same university. In 2010, he spent six months at ETH Zurich within the group of Professor Morari performing research in modelling, identification and control of the complex office buildings. He focuses mainly on renewable energy systems and intelligent and energy efficient building heating, ventilation and air conditioning control systems. Besides that, he has experiences with optimal control of biochemical systems, scheduling in industrial processes and computer vision.

Zdeněk Váňa received his BSc and MSc in Electrical Engineering from the CTU in Prague in 2007 and in 2009, respectively. He is currently a PhD student at the same university. His research interests include systems identification and model-based predictive control, both focused on large scale and singularly perturbed systems. Moreover, he is interested in wavelet transform and its usage in control applications. He has spent four months at NTNU Trondheim cooperating with the group of Professor Preisig and Professor Skogestad dealing with identification problems.

Lukáš Ferkl received his PhD in Control Engineering from Czech Technical University in Prague in 2006 and currently holds a research position at Czech Technical University in Prague, Faculty of Electrical Engineering, Department of Control Engineering. His research interests include system identification and model-based predictive control with the focus on ventilation in tunnels and buildings, as well as reliability analyses.

1 Introduction

1.1 Motivation

With 40% of energy consumption share, buildings contribute significantly to the total energy usage (Perez-Lombard et al., 2008). This poses a strong motivation for development of advanced and energy saving heating, ventilating, and air conditioning (HVAC) systems. A significant amount of energy can be saved using the predictive control strategies compared to the conventional strategies. This has been shown in the OptiControl project (Gyalistras et al., 2010). Widely used control strategy, a weather-compensated control, can lead to a poor energy management or a reduced thermal comfort even if properly set up, because it utilises the current outside temperatures only. In case of sharp change of weather, there is an improper control action due to the energy accumulation in large buildings, resulting in an over- or under-heating of a building. Even though the HVAC control systems have been improved significantly during recent years, the predictive controller described by Privara et al. (2011a, 2011b) introduces a different approach to the heating system control design. There is, however, a crucial condition for the successful control, that is, properly identified model of the system (Zhu, 2009). Model identification can be performed by a large variety of methods, physical modelling or statistical approach among others.

For successful and wide-spread deployment of predictive control algorithms for HVAC systems, an efficient identification method is necessary (Privara et al., 2011a, 2011b). The physical models (sometimes referred to as *first principle models*) can be very accurate, but the time needed for their set up is usually way too long. Statistical methods, on the other hand, can find the models much faster, but they lack accuracy for buildings, as will be discussed further. Incorporation of prior information (PI) may improve their accuracy significantly.

This paper presents incorporation of PI into the subspace state space system identification methods (4SID). 4SID methods originally emerged as a conjunction of linear algebra, geometry and system theory and compared to the classical identification methods [nicely introduced by Ljung (1999)], they provide the user with several advantages such as numerical robustness, natural extension to multiple-input multiple-output (MIMO) systems, etc. There are, however, also some drawbacks, e.g., lack of satisfactory number of data samples, proper order of excitation or strong noise contamination can lead to poor identification results (Ljung, 1999, Willems et al., 2005). Some problems coupled to these methods, such as identification of stable, positive,

real models, etc., using regularisation can be found in Van Gestel et al. (2000), Goethals et al. (2003) or formulated as a constrained optimisation, as in Lacy and Bernstein (2003). The black-box identification, such as 4SID, relies only on experimental data, that is, it may result in biased models (Trnka and Havlena, 2009), or fail in giving a proper model [this problem is addressed by Gevers et al. (2005) and Rojas et al. (2008)].

PI can significantly improve the identification results, however, the current algorithms are not able to provide satisfactory results for the MIMO systems. Previous works, such as Bai and Sastry (1986), count with a single-input single-output (SISO) system only. Even (Trnka and Havlena, 2009) using Bayesian framework approach did not present a method which would treat MIMO system in a satisfactory manner.

1.2 Incorporation of PI

PI is a good tool for improvement of the identification results. Its incorporation can be considered as a bridge between classical identification approaches based on the estimation of a time response of an unknown system base upon, e.g., step or impulse response, and statistically-based identification methods (Ljung, 1999). The system properties, such as steady state gain, settling time, asymptotic stability, dominant time constants, smoothness of step response, etc., can be used in the classical approach to determine the unknown system. The question is, how to involve at least some of these properties into the statistically-based identification, and in particular, into the 4SID methods.

Several methods dealing with above problem have been proposed. They can be generally classified into four groups.

1.2.1 Bayesian framework

This approach can be characterised as a natural way for incorporation of PI because it allows an inference of a prior estimate of unknowns system parameters with information retrieved from measured data. The resulting posterior conditional probability function can be obtained using Bayesian rule

$$p(\theta | y) \propto l(\theta | y)p(\theta), \quad (1)$$

where $p(\theta)$ is the prior probability density function of the parameters and $l(\theta | y)$ the likelihood function for measured data (Peterka, 1984).

Although many satisfactory results were proposed for the incorporation of PI into ARX or ARMAX model

identification (Peterka, 1984), similar strategies do not work well for the class of 4SID methods. This problem is treated, e.g., by Trnka and Havlena (2009), but favourable results are given only for the multiple-input single-output (MISO) systems, because presented algorithm is based on a structured weighted lower rank approximation (SWLRA) (Schuermans et al., 2006), which provides an optimal solution only for the MISO systems. A suboptimal algorithm is presented by Trnka and Havlena (2009), however, the level of optimality is not guaranteed.

1.2.2 Artificial data

Generation of data with desired properties deals with a weak point of 4SID, its black-box character (and associated statistical problems). Such data can contain trends that represent system in a decoupled form (connection of the particular input to the particular output, etc.). As the ratio between artificial and measured data is unknown, the only way how to address this problem is a trial and error method.

1.2.3 Frequency domain identification methods

Yet another approach for system identification is the use of the frequency domain methods. It has been shown that this approach leads to the maximum likelihood formulation of the frequency domain estimation problem (McKelvey, 2002). This problem is treated in detail, e.g., by Marelli et al. (2010), Ag et al. (2010), Schoukens et al. (2010), Wills et al. (2010) and Wang et al. (2010). Even though there were some proposals how to incorporate the PI into an identification algorithm (e.g., Ljung and Gillberg, 2010), it is still an open problem and a topic of ongoing research.

1.2.4 Direct incorporation of system properties into 4SID algorithms

This is the main contribution of this paper and will be treated in detail.

1.3 Organisation of the paper

This paper presents a new algorithm of incorporation of PI, which is built-in directly into the system matrices B and D and does not make use of the covariance matrix, which enables treating MIMO systems in a natural way using state-space approach. Section 2 formulates the general identification algorithm. Section 3 describes incorporation of known system steady state properties into subspace identification framework. Section 4 presents identification results of previously described algorithms. The objective of the identification was creation of a proper model (in sense of fit and controllability) of a real, eight-floor building. Future development is outlined in Section 5 and the paper is concluded by Section 6.

2 Subspace identification

2.1 Problem statement

In the last two decades, the subspace algorithms have become an important tool of system identification. The objective of the 4SID, as will be used further on, is to find a linear, time invariant, discrete time state space model in an innovative form

$$\begin{aligned} x(k+1) &= Ax(k) + Bu(k) + Ke(k) \\ y(k) &= Cx(k) + Du(k) + e(k), \end{aligned} \quad (2)$$

given the measurements of the input $u(k) \in \mathbb{R}^m$ and the output $y(k) \in \mathbb{R}^l$. The set of data

$$Z^N = (u(t), y(t))_{t=1}^N, \quad (3)$$

is generated by an unknown stochastic system of order n , which is equivalent to the well-known stochastic model as defined by e.g., Lewis (1986) and Kalman (1960). The objective of the algorithm is to determine the system order n and to find the A , B , C , D and K matrices.

2.2 General algorithm

The entry point to the algorithm is the input-output equations

$$\begin{aligned} Y_p &= \Gamma_i X_p + H_i^d U_p + H_i^s E_p \\ Y_f &= \Gamma_f X_f + H_f^d U_f + H_f^s E_f \\ X_f &= A^i X_p + H_i^d U_p + H_i^s E_p, \end{aligned} \quad (4)$$

where all the corresponding symbols are explained in Table 1. The basic idea of the algorithm is to drop the input and the noise matrices by finding appropriate projection and instrument matrices. The main tool of 4SID, an oblique projection, is defined as follows (Trnka, 2007; Van Overschee and De Moor, 1999):

$$\mathcal{O} = Y_f \left[W_p^T U_f^T \right]^{-1} \begin{bmatrix} W_p W_p^T & W_p U_f^T \\ U_f W_p^T & U_f U_f^T \end{bmatrix}^\dagger \begin{bmatrix} I_{l \times l} \\ 0 \end{bmatrix} W_p, \quad (5)$$

where l is number of the outputs, $(\bullet)^\dagger$ is Moore-Penrose pseudo-inverse and $W_p = \begin{pmatrix} U_p \\ Y_p \end{pmatrix}$. Equation (5) is in literature often referred to as

$$\mathcal{O} = Y_f /_{U_f} W_p. \quad (6)$$

Table 1 Symbols and their meaning used for SID algorithm

Symbol	Meaning
Y_p	Hankel matrix of the past outputs
Y_f	Hankel matrix of the future outputs
X_f	Hankel matrix of the future states
U_p	Hankel matrix of the past inputs
U_f	Hankel matrix of the future inputs
Γ	Extended observability matrix
H^d	Markov parameter matrix corresponding to the deterministic part
H^s	Markov parameter matrix corresponding to the stochastic part
Δ^d	Reversed extended controllability matrix corresponding to the deterministic part
Δ^s	Reversed extended controllability matrix corresponding to the stochastic part
E_p	Hankel matrix of the past noise
E_f	Hankel matrix of the future noise
i	Prediction horizon
N	Number of data samples

Then it can be shown (see e.g., Van Overschee and De Moor, 1999; Lyzell, 2009), that

$$\mathcal{O} = \Gamma X, \quad (7)$$

where X is the Kalman filter state sequence, i.e., the oblique projection [equation (6)] is a tool how to drop the input and noise matrices. The order of the system can be determined from analysis of the singular values obtained using a singular value decomposition (SVD) of $W_1 \mathcal{O} W_2$, where W_i are the weighting matrices of an appropriate size and determine resulting state space basis as well as importance of the particular element of \mathcal{O} .

The algorithm continues from either Γ or X in a slightly different manner depending on the particular subspace identification algorithm, however, both ways lead to a computation of the system matrices A and C using the least squares method.

In the following, we will use the approach of Lyzell (2009) using a MATLAB-like notation for the selection of a submatrix of a given matrix:

$$\hat{C} = \Gamma(1:l,:), \quad (8a)$$

$$\hat{A} = \Gamma(1:(i-1)*l,:)^{-1} \Gamma(l+1:i*l,:), \quad (8b)$$

Given the \hat{A} and \hat{C} matrices, the estimate of the system matrices B and D (and initial state x_0) is performed in many different ways, see e.g., Van Overschee and De Moor (1999), Lyzell et al. (2009), Ljung (1999), Veen et al. (2010), Poulliquen et al. (2010) and Miller and Callafon (2010); we will adopt the idea of Lyzell (2009). The system output equation can be written as

$$y(k) = CA^k x(0) + \sum_{j=0}^{k-1} CA^{k-j-1} Bu(j) + Du(k) + e(k), \quad (9)$$

with $e(k)$ being the noise contributions. Then equation (9) can be readily rewritten using the operator of vectorisation vec and Kronecker product \otimes as follows:

$$y(k) = CA^k x(0) + \left(\sum_{j=0}^{k-1} u(j)^T \otimes CA^{k-j-1} \right) \text{vec}(B) + \left(u(k)^T \otimes I_l \right) \text{vec}(D) + e(k). \quad (10)$$

The optimisation problem can be then formulated using a matrix form as

$$\theta^* = \arg \min_{\theta} \|\mathcal{Y} - \mathcal{Z}^T \theta\|_2^2 \quad (11)$$

where \mathcal{Y} represents the vectors $y(k)$ stacked onto each other, $\mathcal{Z} = (\varphi(1), \dots, \varphi(N))$, with

$$\varphi^T(k) = \left(\hat{C} \hat{A}^k \sum_{j=0}^{k-1} u(j)^T \otimes \hat{C} \hat{A}^{k-j-1} u(k)^T \otimes I_l \right) \quad (12)$$

and

$$\theta^T = \left(x(0)^T \text{vec}(\hat{B})^T \text{vec}(\hat{D})^T \right) \quad (13)$$

This step is crucial for the incorporation of the PI and therefore will be discussed in detail in Section 3.

Finally, given the estimates of the system matrices A, B, C, D , the Kalman gain matrix K can be computed. If an estimate of a state sequence X is known [e.g., from equation (7)], the problem can be solved by computing the algebraic Riccati equation (ARE) in which the covariance matrices are determined from the residuals as follows:

$$\begin{bmatrix} W \\ V \end{bmatrix} = \begin{bmatrix} X_{k+1} \\ Y_k \end{bmatrix} - \begin{bmatrix} \hat{A} & \hat{B} \\ \hat{C} & \hat{D} \end{bmatrix} \begin{bmatrix} X_k \\ U_k \end{bmatrix}, \quad (14)$$

where

$$\begin{bmatrix} Q & S \\ S^T & R \end{bmatrix} = \frac{1}{N} \left(\begin{bmatrix} W \\ V \end{bmatrix} \begin{bmatrix} W^T & V^T \end{bmatrix} \right). \quad (15)$$

3 Direct incorporation of system properties into 4SID algorithms

The following section tries to sketch out the identification algorithm in a simplified way. The incorporation of all conceivable kinds of PI is shown.

- Computation of an extended observability matrix and the state vector sequence $W_1 \mathcal{O} W_2 = \Gamma X$. Different 4SID algorithms make use of different rules for the computation of these matrices [for reference, see e.g., Van Overschee and De Moor (1999)].

- Estimates of the system matrices A and C based on Γ using the least squares method.
- Determination of the estimates of the matrices B and D and possible incorporation of the PI in this step. The solution will be addressed in Section 3.1.
- Kalman gain computation.

3.1 Knowledge of the static gain

In the following, to make the notation simpler, we will drop the \hat{A} and use only A instead whenever it is appropriate. The subspace identification process consists of several parts (see Figure 1). Each of them corresponds to a particular property of the resulting system. The A matrix contains dynamics of the states, while the C matrix transfers the dynamics to the outputs. Therefore, the system input-output structure is influenced mainly by determination of the B and D matrices, with A and C fixed. Hence, the key idea is to involve the PI about the steady state gain into the B and D matrices. This is especially useful during development of a building model, in a case of so called multi-zone modelling, when gathered data do not possess satisfactory quality.

Let the A and C matrices have already been computed by some two-step 4SID algorithm (see Figure 1). Knowledge of these matrices is then exploited to formulate an optimisation problem, i.e., computation of such B and D matrices that lead to the desired steady state behaviour. This is possible thanks to the fact, that a sum of the elements of the impulse response of an asymptotically stable system is equal to the steady state:

$$D + CB + CAB + CA^2B + \dots = G, \quad (16)$$

that is,

$$\left[I_{l \times l} \sum_{k=0}^{\infty} CA^k \right] \begin{bmatrix} D \\ B \end{bmatrix} = G, \quad (17)$$

where G is a matrix of steady state gains (g_{ij} is the steady state gain from the j^{th} input to i^{th} output):

$$G = \begin{bmatrix} g_{11} & \dots & g_{1m} \\ \vdots & \ddots & \vdots \\ g_{l1} & \dots & g_{lm} \end{bmatrix}. \quad (18)$$

In case of an asymptotically stable A matrix, the following holds [Neumann series convergence theorem, see Stewart (1998)],

$$(I_{n \times n} - A)^{-1} = \sum_{k=0}^{\infty} A^k. \quad (19)$$

Finally, by employing Kronecker product and vectorisation, we get the resulting formula which represents the additional set of constraints that have to be fulfilled:

$$\underbrace{\begin{bmatrix} I_{m \times m} \otimes C(I_{n \times n} - A)^{-1} I_{ml \times ml} \\ \Gamma_s \end{bmatrix}}_{\Gamma_s} \begin{bmatrix} \text{vec}(B) \\ \text{vec}(D) \end{bmatrix} = \text{vec}(G). \quad (20)$$

Now, the calculation of B and D matrices in equation (11) can be performed with the additional constraints equation (20) to accomplish the desired steady state properties:

$$\begin{aligned} \theta^* &= \arg \min_{\theta} \|\mathcal{Y} - \mathcal{Z}^T \theta\|_2^2 \\ \text{s.t. } \text{vec}(G) &= [0_{ml \times n} \Gamma_s] \theta \end{aligned} \quad (21)$$

The aforementioned constrained least-squares problem can be also restated as the weighted least-squares as follows:

$$\theta^* = \arg \min_{\theta} \left\| \begin{bmatrix} \mathcal{Y} \\ \text{vec}(G) \end{bmatrix} - \begin{bmatrix} \mathcal{Z}^T \\ [0_{ml \times n} \Gamma_s] \end{bmatrix} \theta \right\|_W^2, \quad (22)$$

where W is a user-defined weighting matrix that guarantees the desired steady state behaviour.

Incorporating the constraints from equation (20) can be done in two possible ways:

- solve the least squares problem with the equality constraints (21)
- solve the weighted least squares problem (22).

Presented approach for incorporation of system steady state properties is suitable for identification with full prior knowledge of the process, however, for a large process, getting the steady state gain can be a complicated task. In such a case only a submatrix G_{sub} of the gain matrix G is usually known. Then the constraints equation (17) can be modified by two square diagonal matrices S_r, S_c of an appropriate size as

$$S_r \left[I_{l \times l} \sum_{k=0}^{\infty} CA^k \right] \begin{bmatrix} D \\ B \end{bmatrix} S_c = G_{sub} \quad (23)$$

and the further procedure is analogous. Matrices S_r, S_c are 'selectors' of the relevant rows (S_r) and columns (S_c), and contain only ones and zeros for retaining and disposal of the known gain, respectively.

Figure 1 Subspace algorithm with the proposed incorporation of PI step by step (see online version for colours)

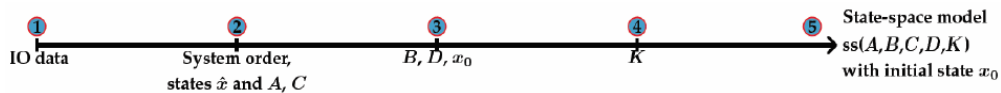

Let us shortly summarise the incorporation of the static gain knowledge. In 4SID algorithm A and C were computed in a standard way [see any 4SID algorithm, e.g., Van Overschee and De Moor (1999)]. The computation of B , D [and initial state $x(0)$ if required] is performed in a standard least-square sense using formulation equation (22). This was possible thanks to equation (23) where users can specify their partial or full knowledge of the static gain.

3.2 Knowledge of input-output feed-through

Often-times in industrial applications, the input-output feed-through of the system to be identified is known in advance. For a general case of a prior knowledge of the feed-through matrix D , the optimisation problem (21) can be restated as follows:

$$\xi^* = \arg \min_{\xi} \|\mathcal{P} - Q\xi\|_2^2 \quad (24)$$

s.t. $\text{vec}(G) - \text{vec}(D) = \mathcal{R}\xi$,

where $\mathcal{R} = [0_{m \times n} \ I_{m \times n} \otimes C(I_{n \times n} - A)^{-1}]$, $\xi^T = [x_0^T \ \text{vec}(B)^T]$, \mathcal{P} is a vector composed of the vectors $\text{vec}(D)$ stacked onto each other and $Q^T = (q(1), \dots, q(N))$, where

$$q(k)^T = \left[CA^k \sum_{j=0}^{k-1} u(j)^T \otimes CA^{k-j-1} \right]. \quad (25)$$

In fact, it is not a rare phenomenon, that there is no input-output feed-through present in the system, that is, [the system matrix D is equal to zero. This will be treated in the following: consider again equation (11), i.e., the computation of B and D matrices. The D matrix can be forced to be zero by computation of equations (21) or (22) using a modified \mathcal{Z} matrix with last m columns eliminated (they correspond to the D matrix).

4 Identification results

The proposed algorithms were implemented and then applied to data gathered from the HVAC system of the building of the Czech Technical University in Prague. The simplified scheme of one building block consisting of three inputs (outside temperature, heating water 1, heating water 2) and four outputs (room temperature 1, return water 1, room temperature 2, return water 2) is depicted in Figure 2.

Data from such an industrial environment do not always have a sufficient quality, they suffer from a strong noise contamination, occurrence of outliers, low excitation, etc. In our case, there is a strong multicollinearity present in the data, that is, the conventional control strategies, which have been used for maintenance of the desired temperature levels, drive both courses (north and south course, as well) of heating water, so that return water and room temperatures

had similar behaviour and were strongly correlated. The black-box identification approach was not able to handle this problem. The PI about the system structure, i.e., the steady state gain and/or no presence of input-output feed-through had to be incorporated to get the desired results. This can be seen in Figure 3, where the step responses of the models identified by the different 4SID approaches are shown. The prior knowledge about the steady state gain was in this case selected as follows:

$$G = \begin{bmatrix} 0.5 & 0.75 & 0.15 \\ 0 & 0.9 & 0 \\ 0.5 & 0.15 & 0.75 \\ 0 & 0 & 0.9 \end{bmatrix}.$$

Figure 2 Simplified scheme of model identification setup (see online version for colours)

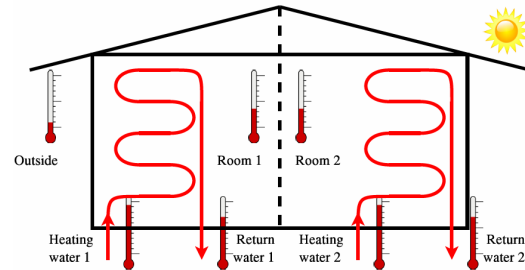

These 4SID methods come, in general, from the robust, combined deterministic and stochastic algorithm as introduced by Van Overschee and De Moor (1999). Moreover, the two methods of Trnka and Havlena (2009) are mentioned for comparison:

- N4SID – version without changes
- N4SID + PI – the steady state gain was included using equation (22). Matrix D is not set to zero
- N4SID-D – matrix D is set to zero but the steady state gain is not included
- N4SID-D + PI – both types of the PI information, i.e., zero D and the steady state gain are incorporated
- Kung and SWLRA – PI incorporated as in Trnka and Havlena (2009), Kung's respectively SWLRA realisation algorithms are used to get system matrices.

The models retrieved from the proposed algorithm were verified against validation data by an open-loop simulation, see Figure 4. SWLRA and Kung's algorithms produced poor results, therefore the open-loop responses are not shown.

Both figures prove the superiority of the identification algorithm with PI included. The identification results can be summed-up as follows.

Figure 3 Comparison of step responses of systems identified using different algorithms (see online version for colours)

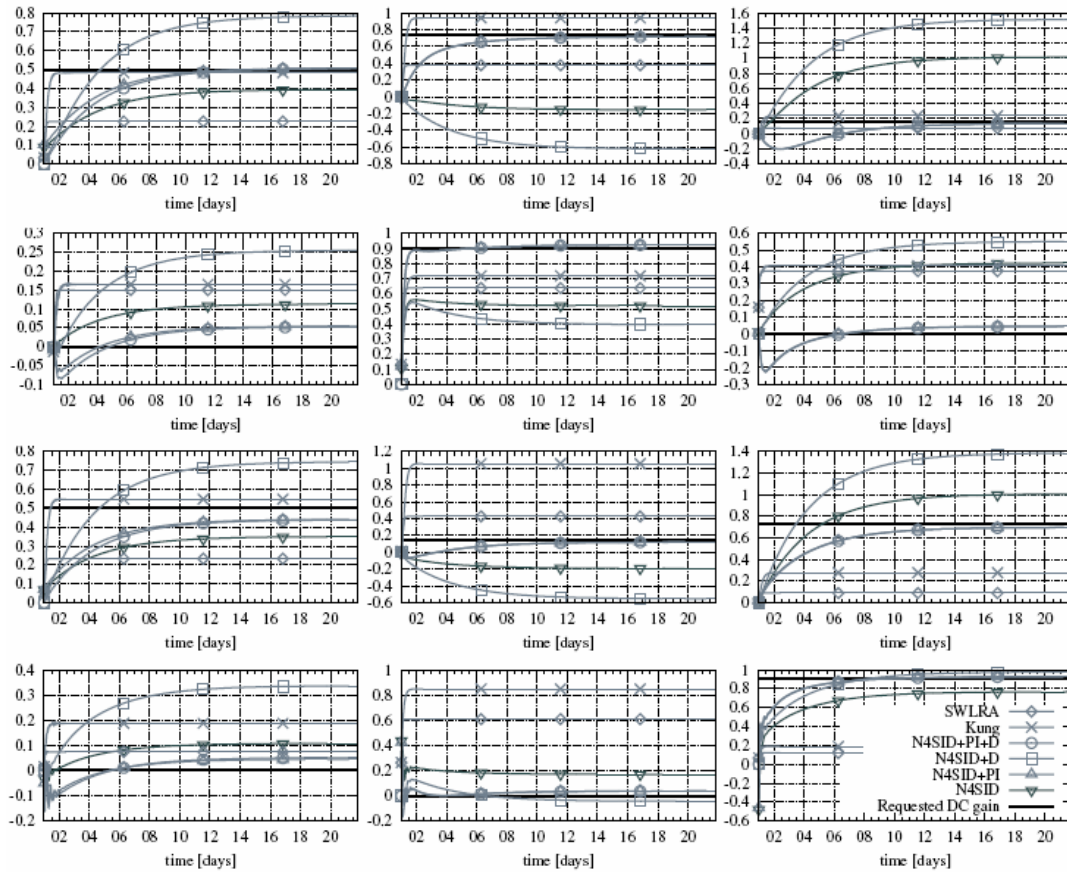

Note: There is a significant improvement in the identification results using PI about the steady state gain.

Figure 4 Comparison of different identification strategies: open-loop simulation (see online version for colours)

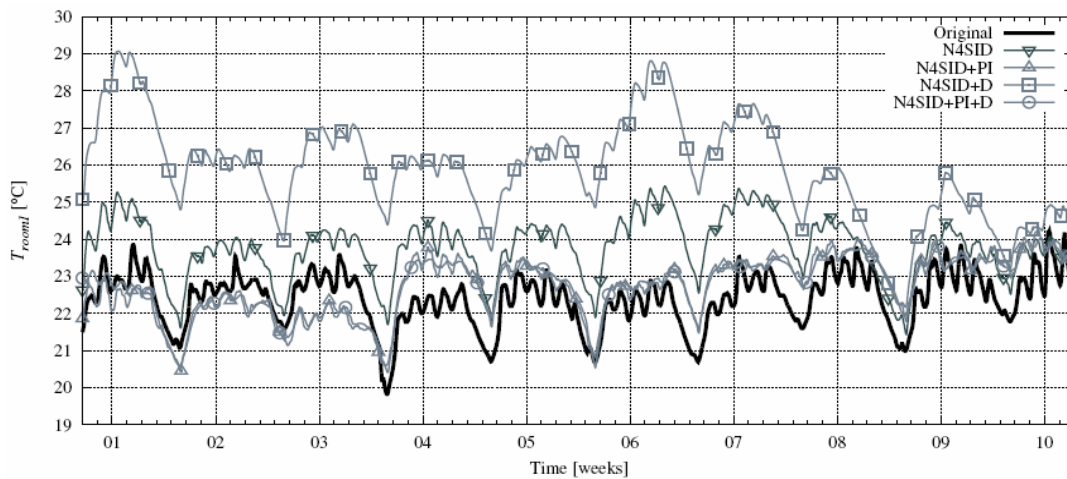

4.1 Zero D matrix

There is almost no difference in results between robust combined algorithm (full D matrix) and algorithm with zero D matrix. This is useful especially in cases, when the nonzero D matrix has no physical meaning in many industrial applications.

4.2 PI in the B and D matrices

The incorporation of the known static gain into the identification algorithm has different consequences for the deterministic and stochastic (in sense of system with noise) algorithms. In case of the deterministic algorithm, PI is able to substitute the lack of information caused by a noise (no presence of the Kalman filter) and significantly improves the identification results. In many cases, it is even not possible to identify a system with noise using the deterministic algorithm without knowledge of PI due to insufficient information and noise contamination; this can be rectified using PI. In the case of the stochastic algorithm, the differences in fit between the algorithm with and without PI is not major, however, the incorporation of PI enables the creation of the model which has properties equivalent to the real physical system, and is valid for control.

4.3 Sensitivity of the true value of PI

The price for the better identification performance in case of PI incorporation must be paid by a greater sensitivity to the changes in parameters, that is, even a slight change in parameters aggravates the identification results (in a sense of a fit). The importance of PI in respective parameters can be adjusted by the weighting matrix in equation (22).

5 Future development

As mentioned in Section 4, there is no SWLRA algorithm for MIMO systems working properly. This is still a topic of ongoing research. In case of successfully solving this problem, PI could be incorporated by means of a Bayesian network, as proposed by Trnka and Havlena (2009), even to the MIMO systems. Yet another approach was presented in this article via a direct incorporation of PI into the system matrices B and D . There is, however, PI of a certain type (e.g., dynamics), which must be incorporated directly into the A or C matrices; however, the solution to this problem is still unknown, and topic of possible research as well.

6 Conclusions

The proposed algorithm presents an incorporation of PI into the subspace identification methods. The incorporation is performed directly into the system matrices B and D , thus enables a certain type of PI, e.g., static gain. The incorporated PI is able to significantly improve the identification results and substitute the lack of information

in the input-output data. Moreover, it notably improves the model for control purposes by shaping it into the physical structure of the real system. However, the quality of the identification is sensitive to the accuracy of the prior estimate of parameters. A constructed model has been used for temperature control in a real operation of the 8-floor building of the Czech Technical University in Prague. The predictive control with the model identified using the proposed algorithm achieved 27% savings of energy, compared to the state-of-the-art weather-compensated controller (Siroký et al., 2011).

Acknowledgements

This work has been supported from the state budget of the Czech Republic, through the Ministry of Industry and Commerce in the scope of grant no. 2A-1TP1/084, 'Integration of building systems, research and application of intelligent algorithms with influence on energy consumption of buildings and living houses'.

References

- Ag, J.C., Yuz, J.I., Goodwin, G.C. and Tang, W. (2010) 'Identification of state-space systems using a dual time-frequency domain approach', in *49th IEEE Conference on Decision and Control*, No. 50905140, Atlanta, pp.2863–2868.
- Bai, E. and Sastry, S. (1986) 'Parameter identification using prior information', *International Journal of Control*, Vol. 44, No. 2, pp.455–473.
- Gevers, M., Euler, B. and Lemaître, A. (2005) 'Identification for control: achievements and open problems', *Dynamics and Control of Process Systems 2004*, p.401.
- Goethals, I., Van Gestel, T., Suykens, J., Van Dooren, P. and De Moor, B. (2003) 'Identifying positive real models in subspace identification by using regularization', in *Proceedings of the 13th System identification Symposium*, Rotterdam, The Netherlands, Citeseer, pp.1411–1416.
- Gyalistras, D. et al. (2010) 'Use of weather and occupancy forecasts for optimal building climate control', Technical report, ETH Zürich.
- Kalman, R. (1960) 'A new approach to linear filtering and prediction problems', *Journal of basic Engineering*, Vol. 82, No. 1, pp.35–45.
- Lacy, S. and Bernstein, D. (2003) 'Subspace identification with guaranteed stability using constrained optimization', *IEEE Transactions on Automatic Control*, Vol. 48, No. 7, pp.1259–1263.
- Lewis, F. (1986) *Optimal Estimation with an Introduction to Stochastic Control Theory*, Wiley New York.
- Ljung, L. (1999) *System Identification: Theory for User*, Prentice-Hall, Inc., Upper Saddle River, New Jersey, USA.
- Ljung, L. and Gillberg, J. (2010) 'Frequency domain identification of continuous-time output error models, Part I: uniformly sampled data and frequency function approximation', *Automatica*, Vol. 46, No. 1, pp.1–10.

- Lyzell, C. (2009) 'Initialization methods for system identification', Licentiate thesis no. 1426, Department of Electrical Engineering, Linköping University, SE- 581 83 Linköping, Sweden.
- Lyzell, C., Enqvist, M. and Ljung, L. (2009) 'Handling certain structure information in subspace identification', in *Proceedings of the 15th IFAC Symposium on System Identification*.
- Marelli, E., Godoy, B.I. and Goodwin, G.C. (2010) 'A scenario-based approach to parameter estimation in state-space models having quantized output data', in *49th IEEE Conference on Decision and Control*, Atlanta, pp.2011–2016.
- McKelvey, T. (2002) 'Frequency domain identification methods', *Circuits, Systems, and Signal Processing*, Vol. 21.
- Miller, D.N. and Callafon, R.A.D. (2010) 'Subspace identification using dynamic invariance in shifted time-domain data', in *49th IEEE Conference on Decision and Control*, Atlanta, No. 0, pp.2035–2040.
- Perez-Lombard, L., Ortiz, J. and Pout, C. (2008) 'A review on buildings energy consumption information', *Energy and Buildings*, Vol. 40, No. 3, pp.394–398.
- Peterka, V. (1984) 'Predictor-based self-tuning algorithm', *Automatica*, Vol. 20, No. 1, pp.39–50.
- Pouliquen, M., Gehan, O. and Pigeon, E. (2010) 'An indirect closed loop subspace identification method', in *49th IEEE Conference on Decision and Control*, Atlanta, No. 3, pp.4417–4422.
- Privara, S., Šíroký, J., Ferkl, L. and Cigler, J. (2011a) 'Model predictive control of a building heating system: the first experience', *Energy and Buildings*, Vol. 43, Nos. 2–3, pp.564–572.
- Privara, S., Váňa, Z., Gyalistras, D., Cigler, J., Sagerschnig, C., Morari, M. and Ferkl, L. (2011b) 'Modeling and identification of a large multi-zone office building', in *2011 IEEE Multi-Conference on Systems and Control*, Denver.
- Rojas, C., Barenthin, M., Welsh, J. and Hjalmarsson, H. (2008) 'The cost of complexity in identification of FIR systems', in *16th IFAC World Congress. Seoul, South Korea*.
- Schoukens, J., Rolain, Y. and Pintelon, R. (2010) 'On the use of parametric and non-parametric noise-models in time- and frequency domain system identification', in *49th IEEE Conference on Decision and Control*, Atlanta, pp.316–321.
- Schuermans, M., Lemmerling, P. and S.V. H. (2006) 'Block-row Hankel weighted low rank approximation', *Numerical Linear Algebra with Applications*, Vol. 13, No. 4, pp.293–302.
- Síroký, J., Oldewurtel, F., Cigler, J. and Privara, S. (2011) 'Experimental analysis of model predictive control for an energy efficient building heating system', *Applied Energy*, Vol. 88, No. 9, pp.3079–3087.
- Stewart, G.W. (1998) *Matrix Algorithms: Volume 1, Basic Decompositions*, Society for Industrial Mathematics.
- Trnka, P. (2007) 'Subspace identification methods', PhD thesis, Czech Technical University in Prague.
- Trnka, P. and Havlena, V. (2009) 'Subspace like identification incorporating prior information', *Automatica*, Vol. 45, No. 4, pp.1086–1091.
- Van Gestel, T., Suykens, J., Van Dooren, P. and De Moor, B. (2000) 'Identification of positive real models in subspace identification with regularization', *IEEE Transactions on Automatic Control*, Vol. 46, No. 9, pp.1416–1420.
- Van Overschee, P. and De Moor, B. (1999) *Subspace identification for Linear Systems*, Kluwer Academic Publishers, Kluwer Academic Publishers, 101 Philip Drive, Assinippi Park, Nowell, Massachusetts.
- Veen, G.V.D., Wingerden, J-w.V. and Verhaegen, M. (2010) 'Closed-loop MOESP subspace model identification with parametrisable disturbances', in *49th IEEE Conference on Decision and Control*, Atlanta, pp.2813–2818.
- Wang, Y., Xu, X. and Cai, W. (2010) 'Online multivariable process identification in the frequency domain', *International Journal of Modelling, identification and Control*, Vol. 10, No. 1, pp.106–111.
- Willems, J.C., Rapisarda, P., Markovsky, I. and Moor, B.L.D. (2005) 'A note on persistency of excitation', *Systems and Control Letters*, Vol. 54, No. 4, pp.325–329.
- Wills, A., Sch, T.B. and Ninness, B. (2010) 'Estimating state-space models in innovations form using the expectation maximisation algorithm', in *49th IEEE Conference on Decision and Control*, Atlanta, No. 5, pp.5524–5529.
- Zhu, Y. (2009) 'System identification for process control: recent experience and outlook', *International Journal of Modelling, Identification and Control*, Vol. 6, No. 2, pp.89–103.

Control Engineering Practice paper entitled *Use of partial least squares within the control relevant identification for buildings* present the concept of multi-step ahead error minimization, when the control and identification criteria commensurate ensuring thus the best possible model in sense of multi-step ahead predictor.

As there is often noise contamination present or the number of covariates used for regression problem is too large, and a number of them does not contribute significantly to improve the solution, some of the components can be removed. This is performed by the combination of the [MRI](#) and [PLS](#).

The algorithm is tested at the provided example.

The share of the author on the result according to VVVS is 47%. The following numbers lists citation not including auto-citations.



Contents lists available at SciVerse ScienceDirect

Control Engineering Practice

journal homepage: www.elsevier.com/locate/conengprac

Use of partial least squares within the control relevant identification for buildings[☆]

Samuel Prívvara^{a,*}, Jiří Cigler^a, Zdeněk Váňa^a, Frauke Oldewurtel^b, Eva Žáčková^a

^a Department of Control Engineering, Faculty of Electrical Engineering, Czech Technical University in Prague, Technická 2, 166 27 Praha 6, Czech Republic

^b Power Systems Laboratory, Department of Electrical Engineering, Swiss Federal Institute of Technology in Zurich (ETHZ), Switzerland

ARTICLE INFO

Article history:

Received 7 October 2011

Accepted 28 September 2012

Available online 22 October 2012

Keywords:

Predictive control relevant identification

Statistical identification

Building modeling

ABSTRACT

Climate changes, diminishing world supplies of non-renewable fuels, as well as economic aspects are probably the most significant driving factors of the current effort to save energy. As buildings account for about 40 % of global final energy use, efficient building climate control can significantly contribute to the saving effort. Predictive building automation can be used to operate buildings in an energy and cost effective manner with minimum retrofitting requirements. In such a predictive control approach, dynamic building models are of crucial importance for a good control performance. An algorithm which has not been used in building modeling yet, namely a combination of minimization of multi-step ahead prediction errors and partial least squares will be investigated. Subsequently, two case studies are presented: the first is an artificial model of a building constructed in Trnsys environment, while the second is a real-life case study. The proposed identification algorithm is then validated and tested.

© 2012 Elsevier Ltd. All rights reserved.

1. Introduction

1.1. Energy management in buildings

There are several reasons why building climate control has been drawing attention in recent years in both academic and industrial fields. Buildings account for about 40% of the total final energy consumption, and in developed countries, the per year increases are 0.5–5% (Laustsen, 2008; Pérez-Lombard, Ortiz, & Pout, 2008). Moreover, buildings produce 33% of global CO₂ emissions (Dascalaki, Droutsa, Gaglia, Kontoyiannidis, & Balaras, 2010). On the other hand, they have very large potential of both primary energy and CO₂ reduction (Metz, 2007). Moreover, as pointed out by Ekns and Lees (2008), currently available energy efficiency measures could save 28% of the current energy consumption. This can be done by refurbishment (e.g. installation of building integrated photovoltaic system for preheating of the fresh air Lodi, Bacher, Cipriano, & Madsen, 2012), using the energy certificates, changing thus the user behavior (actually, the Energy Performance of Buildings Directive of European Commission requires the residential buildings to have Energy Performance Certificate when they are sold, rented or reconstructed) (Bull, Chang, & Fleming, 2012) or optimization techniques applied to building

automation systems (BAS) (Široký, Oldewurtel, Cigler, & Prívvara, 2011). The latter case is focused on in this paper.

The current practice in a building temperature control is heating-curve controllers which require no model of a process (see e.g. Tashtoush, Molhim, & Al-Rousan, 2005; Zhu, 2001) and are implemented in the topmost level of a control hierarchy. The respective subsystems of heating, ventilation and air conditioning (HVAC) are then controlled by rule-based controllers (RBC, “if-then-else”), which are mainly responsible for a specific and space-limited area. A control performance is then highly dependent on a huge number of threshold values and parameters. With higher complexity of the BAS and HVAC systems, it is increasingly difficult to achieve energy efficient formulations of these rules at the building level.

Model Predictive Controller (MPC) opens up possibilities of exploiting thermal storage capacities making use of a prediction of future disturbances (internal gains due to presence of people and equipment, weather, etc.) given some specific requirements, such as acceptable ranges (single value set-points still remain possible to set) for controlled variables, known in advance or at least estimated ranges for controlled variables, disturbances, control costs, etc. An increase in research in the field of MPC used in BAS or HVAC (see e.g. Ma et al., 2011; Oldewurtel et al., 2010) mirrored in the applications and successful operation on the real buildings (Lukasse et al., 2009; Prívvara, Široký, Ferkl, & Cigler, 2011). The analyses of a savings potential by employing predictive strategies were addressed in e.g. Gyalistras et al. (2010), Oldewurtel et al. (2010) and Cigler, Prívvara, Váňa, Žáčková, and Ferkl (2012).

[☆] The results in the paper were partly written during the visit at IfA, ETH Zurich.

* Corresponding author. Tel.: +420 776 697672.

E-mail address: samuel.privvara@fel.cvut.cz (S. Prívvara).

1.2. Model Predictive Control for buildings

MPC is a modern control technique, which is characterized by its ability to handle constrained optimal control problems. At each time step, a constrained optimization problem on a finite horizon is solved for the current state of a building and the solution is then applied. In fact, at each time step a plan for heating, cooling, ventilation, etc. is computed for the optimization horizon based on predictions of future weather conditions and other disturbances (e.g. occupancy, internal gains, etc.). Time-dependencies of the control costs (e.g. dynamic electricity prices), or of the constraints (e.g. thermal comfort range) can readily be included into an optimization (Oldewurtel et al., 2010).

1.3. Modeling and identification

The reliable prediction properties of an identified dynamic model are vital for a good performance of MPC. The need for a good model has led to an intensive research in the field of building model identification (Ferkl & Široký, 2010; Gyalistras & Gwerder, 2009; Privara, Váňa, Žáčková, & Cigler, 2012; Váňa & Preisig, 2012; Žáčková, Privara, & Váňa, 2011). It is a well-known fact that modeling and identification are the most difficult and time-consuming parts of an automation process as such (Bars et al., 2006; Zhu, 2001), particularly for predictive control technologies. The basic conditions that each model intended for an MPC usage should satisfy, are reasonable simplicity, a well estimated system dynamics as well as satisfactory prediction properties (on a multi-step prediction horizon). These requirements do not need to be of the same quality on the whole frequency range, they should rather comply with the quality requirements for a control-relevant frequency range, see e.g. Hjalmarsson (2009), Gopaluni, Patwardhan, and Shah (2004) and Shook, Mohtadi, and Shah (2002).

Basically, there are four main categories for building modeling techniques.

- *Subspace methods family* (4SID) is a family of algorithms estimating a model of a system in a state space form (Van Overschee & De Moor, 1999). They work purely in a statistical manner and belong to the *black-box* identification algorithms.
- *Probabilistic semi-physical modeling* (PSPM) utilizes stochastic differential equations for the description of the system to be identified (Andersen, Madsen, & Hansen, 2000; Bacher & Madsen, 2011; Bohlin & Graebe, 2007). Then a maximum likelihood estimation (ML) is employed to obtain unknown parameters. This method naturally enables an incorporation of a prior information.
- *Grey box modeling* using a Resistance Capacitance (RC) network in analogue to an electric circuit is a very popular approach when the structure of a system is defined and the parameters are estimated using some optimization tools (Jimenez, Madsen, & Andersen, 2008; Levermore, 1992; Wang & Xu, 2006).
- *MPC relevant identification (MRI)*. While the traditional system identification aims at minimizing the bias and variance of the errors to fit the model, control relevant identification (Rivera, Pollard, & Garcia, 1992) aims at obtaining a model intended for control. In case of the MPC this is referred to as MRI (Gopaluni, Patwardhan, & Shah, 2002, 2004; Laurí, Martínez, Salcedo, & Sanchis, 2010; Shook et al., 2002). MRI is an approach minimizing multi-step ahead prediction errors. The horizon for an error minimization commensurate with a prediction horizon of the predictive controller.

A new algorithm in the field of building modeling is introduced in the paper. MRI combined with Partial Least Squares (PLS) (later on denoted as MRI+PLS) is an approach combining a

minimization of the multi-step ahead prediction errors and a selection of the most important directions in the measured data.

1.4. Contribution and structure of the paper

The main contribution of this paper is twofold: Firstly, a new algorithm based on a method used in different fields is proposed, which is, however, completely novel in building modeling, namely MRI+PLS. Secondly, the algorithm is validated and tested on two examples; a simulation model built in Trnsys and a real building of the Czech Technical University in Prague. The effectiveness and applicability of MRI and MRI+PLS is demonstrated on both examples.

The paper is further structured as follows. In order to formulate the problem and to introduce the necessary terminology, the paper starts with the formulation of the MPC problem for buildings, see Section 2. Section 3 discusses the minimization of the multi-step ahead prediction error and introduces a new algorithm in the field of a building automation – combination of MRI and partial least squares. Section 4 is devoted to case studies, where the properties of the said algorithms are examined. The last section contains final remarks and concludes the paper.

2. Model Predictive Control for buildings

In this setup the control is assumed to be performed at two levels (Široký et al., 2011): a low-level controller (often RBC or PID loops) operates on the level of setpoints predefined by a high level controller (MPC) operating at the level of a whole building. MPC in buildings is used for the control of heating, cooling, ventilation, blind positioning, electrical lighting, humidity, etc.

2.1. MPC strategy

The MPC is not a single strategy, it is rather a class of constrained control algorithms, which originated in the late seventies and early eighties in the process industries (oil refineries, chemical plants, etc.) (see e.g. Richalet, Rault, Testud, & Papon, 1978). The MPC requires the model of a process in order to compute the optimal control input. At each time step a finite horizon optimal control problem is solved resulting in a sequence of inputs which, applied to the process being optimized, satisfies the constraints and moreover, minimizes the given optimization criterion. This would, however, result to an open loop control with all its problems. Therefore, only the first step of the control plan is applied to the process. Then the procedure moves one step forward and is repeated at the next time step, closing thus the loop. This approach, so-called receding horizon, introduces a feedback into the system, while at each time step, a new optimal control action is computed as a function of the new state, hence of any disturbances acting on the process.

2.2. MPC for buildings

In the context of the building control, the computation of the optimal control action means that at each time step, the plans for heating, cooling, ventilation, blind positioning, electric lighting, etc. are computed in such a way that the temperature, CO₂ and luminance levels in rooms or building zones stay within the desired comfort ranges and the physical and economic (or any other) constraints are satisfied. To compute the optimal input MPC needs (i) the initial state, (ii) the model of a process, and (iii) the predictions of the upcoming weather conditions and other disturbance variables such as internal gains, occupancy, etc. Time-dependencies of the control costs (e.g. dynamic electricity prices),

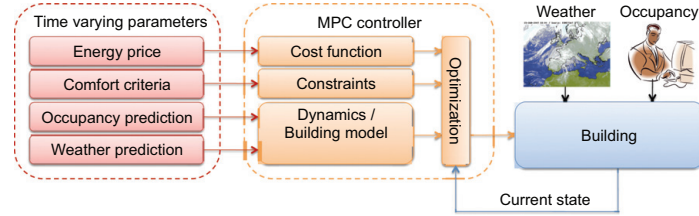

Fig. 1. Basic principle of Model Predictive Control for buildings.

of the constraints (e.g. thermal comfort range) can be readily included in the optimization.

The basic principle of the MPC is depicted in Fig. 1. In the most general case, the inputs to the MPC (the energy price, the comfort criteria, as well as predictions of the weather and occupancy) are time varying. The cost function and the constraints formulate a mathematical description of a desired behavior. In order to the MPC being able to compute the optimal input, a process model must be at hand. The procedure of obtaining the model suitable for a predictive control is thoroughly described in Section 3.

2.3. Mathematical formulation

The MPC finite-horizon optimization problem is often formulated as follows (for a comprehensive overview on the MPC formulations, refer to e.g. Maciejowski, 2001):

$$\min_{u_0, \dots, u_{p-1}} \sum_{k=0}^{p-1} (v_k - y_k)^T Q_k (v_k - y_k) + R_k u_k, \quad (1)$$

$$\text{s.t.} \quad x_0 = x, \quad (2)$$

$$x_{k+1} = f(x_k, u_k, w_k), \quad (3)$$

$$y_k = g(x_k, u_k, v_k), \quad (4)$$

$$(x_k, u_k, y_k) \in \mathcal{X}_k \times \mathcal{U}_k \times \mathcal{Y}_k, \quad (5)$$

where $x_k \in \mathbb{R}^n$ is the system state, $u_k \in \mathbb{R}^m$ is the control input, $y_k \in \mathbb{R}^l$ is the system output, y_k^r is the reference, $w_k \in \mathbb{R}^n$ is the process noise, $v_k \in \mathbb{R}^l$ is the measurement noise, k is the time step, \mathcal{X}_k , \mathcal{U}_k and \mathcal{Y}_k denote the constraint sets of the states, inputs and outputs, P is the prediction horizon. The common practice is to formulate the cost function so that the optimal cost guarantee the stability, i.e. forms a Lyapunov function. As buildings belong to slower and stable processes, this condition is relaxed and Eq. (1) is usually expressed purely on a performance basis, which means that a user specifies preferences for the particular parts of the cost function. Note that the main goal of the formulation of Eq. (1) is to minimize the energy cost while respecting comfort constraints. Q_k and R_k are the time varying matrices of an appropriate size. A trade-off between the precision of a reference tracking and the energy consumption is expressed by the proportion of Q_k and R_k . The reference tracking is expressed as a quadratic form because it significantly penalizes larger deviations from the reference. The energy bill is usually an affine function of a total amount of consumed energy, therefore the control cost is weighed linearly.

Eq. (1) is not the only cost function applicable to the building control. There can be, for instance, a peak energy demand penalization included in the energy bill that can be expressed by L^∞ norm of control inputs in the cost function.

The system model is initialized to the measured/estimated current state of the building Eq. (2). The system state has physical meaning only in cases when an approach using a physical description

of a system is employed. On the other hand, for purely statistical approaches, the system state has no physical meaning. In the case that the measurements of the state are not available, a Kalman filter can be used to its estimation and the estimate is then used as the initial state.

A mathematical description of a building dynamics is a critical part of the MPC controller, significantly influencing the overall performance. A general description of the time invariant system dynamics is presented in Eqs. (3) and (4), however, the work addressed in this paper is restricted to linear time invariant stochastic systems

$$\begin{aligned} x_{k+1} &= Ax_k + Bu_k + w_k, \\ y_k &= Cx_k + Du_k + v_k, \end{aligned} \quad (6)$$

which is the most common model type as it results in a convex and easily solvable optimization problem if the constraints form polytopic sets and stochastic disturbances are replaced by their estimates based upon the information available at the time. A , B , C , D are the system matrices of appropriate size, while w_k and v_k are zero mean white noise sequences entering the system.

The ability to specify constraints in the MPC formulation and to have the optimization routine handling them directly, is the key strength of the MPC approach (Široký et al., 2011). The following explanation holds for the input, state and output constraints alike. Most of the constraints can be formulated as linear inequalities

$$u_{\min, k} \leq u_k \leq u_{\max, k}. \quad (7)$$

For formulation of others refer to Široký et al. (2011).

3. Minimization of multi-step ahead prediction errors

3.1. Model Predictive Control relevant identification

Prediction error methods (PEM) (Ljung, 1999) belong to the most often used methods for system identification and can be formulated as

$$\hat{\theta} = \arg \min_{\theta} \sum_{k=1}^N \varepsilon_k^2(\theta), \quad (8)$$

where θ is the vector of parameters and ε_k the prediction error in time k , i.e. $\varepsilon_k = y_k - \hat{y}_k$, with \hat{y}_k denoting the output estimate and N denotes the number of samples.

Typically, the identification objective function minimizes Eq. (8). However, when the model for the MPC is being built, the minimization of the control error on the prediction horizon should be aimed at. Hence the model should be primarily a good multi-step predictor. The methods that optimize the model on the same horizon as used later for control are collectively called control relevant identification and if the MPC is considered for control, then they are called MPC relevant identification methods (Lauri et al., 2010) (MRI). The problem is addressed in detail in the following.

3.1.1. Problem formulation

The generic MPC cost function, see e.g. Eq. (1) penalizes the sum of squared differences of the actual value of the controlled output y_k and the required reference output y_k^r during the prediction horizon. Without penalization on control actions and after simple adjustments, Eq. (1) can be written as

$$J_{MPC} = \frac{1}{(N-P)P} \sum_{k=1}^{N-P} \sum_{i=1}^P (y_{k+i}^r - y_{k+i})^2, \quad (9)$$

where N is the number of samples and P is the prediction horizon. For buildings, P is typically chosen so that it corresponds to 6–48 h, while N is significantly larger. Next, $y_{k+i} = \hat{y}_{k+i|k} + e_{k+i|k}$, where $\hat{y}_{k+i|k}$ denotes the predicted output values at the time $k+i$ using the data until k , $e_{k+i|k}$ is the i -step ahead prediction error. Eq. (9) can be rewritten (Gopaluni et al., 2002) as

$$J_{MPC} = \frac{1}{(N-P)P} \sum_{k=1}^{N-P} \sum_{i=1}^P (y_{k+i}^r - y_{k+i|k})^2 + \frac{1}{(N-P)P} \sum_{k=1}^{N-P} \sum_{i=1}^P (y_{k+i} - \hat{y}_{k+i|k})^2 - \frac{2}{(N-P)P} \sum_{k=1}^{N-P} \sum_{i=1}^P (y_{k+i}^r - \hat{y}_{k+i|k})(y_{k+i} - \hat{y}_{k+i|k}). \quad (10)$$

The MPC itself minimizes only the first term. However, from the global perspective, to achieve the optimal solution, it is necessary minimize the remaining terms as well. The last term represents the cross-correlation between the identification and control errors and is treated by Gevers (2002). The second term in Eq. (10) will be used as an identification loss function for MRI and expresses the identification error

$$J_{MRI} = \frac{1}{(N-P)P} \sum_{k=1}^{N-P} \sum_{i=1}^P \|e_{k+i|k}\|^2 = \|E_a\|^2, \quad (11)$$

or with explicit dependence on estimated parameters Θ as

$$J_{MRI}(\Theta) = \|E_a\|^2 = \|Y_a - Z_a(\Theta)\|^2, \quad (12)$$

with

$$E_a = \begin{bmatrix} E_{a1} \\ \vdots \\ E_{aP} \end{bmatrix}, \quad E_{ai} = \begin{bmatrix} e_{1+i|1} \\ \vdots \\ e_{N|N-i} \end{bmatrix}, \quad i = 1, \dots, P, \quad (13)$$

and similarly defined output matrix Y_a and regressor Z_a . The specific form of a regressor depends on the model used.

3.1.2. Estimation of ARX models

In the case that AutoRegressive eXternal input (ARX) (Ljung, 1999) model is considered, the multi-step output prediction $\hat{y}_{k+i|k}$ is expressed as

$$\hat{y}_{k+i|k} = Z_{k+i} \hat{\Theta}, \quad i = 1, 2, \dots, P. \quad (14)$$

where $\hat{\Theta} = [\hat{b}_{n_k}, \dots, \hat{b}_{n_b}, \hat{a}_1, \dots, \hat{a}_{n_a}]^T$ and $Z_{k+i} = [u_{k+i-n_k}, \dots, u_{k+i-n_b}, y_{k+i-1}, \dots, y_{k+i-n_a}]$, n_b and n_a are the numbers of lagged inputs and outputs, n_k represents the relative lag of outputs w.r.t. to inputs. As the outputs y_{k_0} in Z_{k+i} with $k_0 > k$ are not available at k , the output prediction $\hat{y}_{k_0|k}$ is obtained recursively from Eq. (14), i.e. by an iterative use of one-step ahead predictions. Having formed the Z_a and Y_a according to Eq. (13), the problem can be solved by available solvers minimizing Eq. (12).

3.1.3. Estimation of state space models

A state space representation is more convenient for MIMO systems than e.g. ARX parametrization. When all the states are measurable and $n_a = n_b = 1$, the relation between $\hat{\Theta}$ and system

matrices A and B can be expressed as

$$\Theta = \begin{bmatrix} B^T \\ A^T \end{bmatrix}, \quad (15)$$

that is, C is a unit matrix and A and B can be readily extracted from $\hat{\Theta}$.

A more difficult situation occurs when not every state is measurable and some input–output pair is represented by a higher-order transfer function $n_b > 1$ for the j -th input. Then the artificial outputs (by means of A_{aux} and B_{aux}) are introduced and thus all the states are made “measurable”. The corresponding parameters are then estimated by minimizing Eq. (12) using the MIMO ARX structure.

Without the loss of generality, let us assume that the output which depends on the lagged input is the first one. Then $n_b - 1$ auxiliary variables in matrices A_{aux} and B_{aux} are introduced

$$\begin{bmatrix} x_{n_b+1,k+1} \\ \vdots \\ x_{n_b+n_b-1,k+1} \end{bmatrix} = A_{aux} \begin{bmatrix} x_{n_b+1,k} \\ \vdots \\ x_{n_b+n_b-1,k} \end{bmatrix} + B_{aux} u, \quad (16)$$

where A_{aux} and B_{aux} are in the following form:

$$A_{aux} = \begin{bmatrix} 0 & 1 & 0 & \dots & 0 \\ 0 & 0 & 1 & 0 & \vdots \\ \vdots & \vdots & \vdots & \ddots & \vdots \\ 0 & \dots & \dots & \dots & 0 \end{bmatrix}, \quad (17)$$

$$B_{aux} = \begin{bmatrix} \mathbf{0}_{j-1} & \begin{bmatrix} 0 \\ \vdots \\ 0 \end{bmatrix} & \mathbf{0}_{n_b-j} \\ & & 1 \end{bmatrix}, \quad (18)$$

with $\mathbf{0}_{j-1}$ and $\mathbf{0}_{n_b-j}$ being the appropriate size zero matrices and n_i and n_o being the number of inputs and outputs, respectively. Then, the system matrices can be expressed as

$$\bar{A} = \begin{bmatrix} A & \begin{bmatrix} b_{n_b,j} & b_{n_b-1,j} & \dots & b_{2,j} \end{bmatrix} \\ \mathbf{0} & A_{aux} \end{bmatrix}, \quad \bar{B} = \begin{bmatrix} B \\ B_{aux} \end{bmatrix} \quad (19)$$

with A and B computed analogously as in Eq. (15) omitting the coefficients corresponding to the influence of the lagged input. These coefficients are stored in the last $n_b - 1$ elements of the first row of \bar{A} . Note that j denotes the lagged input channel. A similar procedure is used in the case when more than one output is affected by the lagged input. Matrix C is a matrix with as many rows as system outputs (original, without artificial outputs created by introducing the auxiliary states) and as many columns as system states. Matrix D is a zero matrix.

3.2. Partial least squares

A collinearity (Mason & Perreault, 1991) (high correlation of predictor variables) leads to numerical problems in a regression. Frequently used solution is then a use of latent variable methods (LVMs) (Farrar & Glauber, 1967; Kiers & Smilde, 2007) such as multivariate linear regression (MVR), principal component analysis (PCA), partial least squares (PLS) or others. In fact a continuum regression (Stone & Brooks, 1990) showed a relationship between these three by a choice of parameter $\beta \in (0, 1)$, when $\beta = 0$ leads to MLR, $\beta = 0.5$ means PLS and $\beta = 1$ results in PCA.

Let us discuss the basic idea now. Matrix Z is a regressor and $\hat{\Theta}$ is a solution of a well-known formula of Ordinary Least Squares (OLS) solution

$$\hat{\Theta} = (Z^T Z)^{-1} Z^T Y. \quad (20)$$

In the case of collinearity $Z^T Z$ is ill-conditioned, hence OLS fitting results in parameters with large variance. Given lumped outputs Y and regressor Z , a variable reduction can be performed

$$\begin{aligned} Y &= UQ^T + F, \\ Z &= TP^T + E, \end{aligned} \quad (21)$$

where U and T are the scores and Q and P are the loadings for Y and Z , respectively, F and E are the residuals. The number of columns of U and T is given by the number of principal components npc that is acquired by minimizing the means squared error of prediction (MSEP)

$$MSEP = \frac{1}{N} \sum_{k=1}^N \|y_k - \hat{y}_k\|^2. \quad (22)$$

It was shown by Höskuldsson (1988) that the MSEP is a trade-off between the bias and variance errors. More columns mean smaller the bias error but larger the variance error and vice versa. npc is often decided by evaluating the MSEP in cross-validation.

Different methods to determine P and Q in Eq. (21) give name to a different LVMs. PLS is a method to model a response variable when there is a large number of predictor variables, and the predictors are highly correlated or even collinear. Then new predictors, known as principal components, are constructed as linear combinations of the original predictor variables. They find a multidimensional direction in the Z -space that explains a maximum variance direction in the Y -space which means that the correlation between columns of T and U is maximized. The resulting response variable then has fewer components.

In principle, the computation is performed as follows. The original regression problem

$$\hat{Y} = Z\hat{\Theta}, \quad (23)$$

transformed to the space of the latent variable using Eq. (21) is equivalent to

$$\hat{U} = T\hat{B}, \quad (24)$$

with $\hat{\Theta}$ being the vector of a parameter estimate in an “outer” and \hat{B} in an “inner” regression problem, respectively. The inner regression thus provides a model in the latent variable space, while the outer regression in the original variable space. To obtain T with orthogonal columns W s.t. $ZW = TP^T W$ is introduced. Then

$$\begin{aligned} \hat{Y} &= Z\hat{\Theta} = \hat{U}Q^T = T\hat{B}Q^T \quad \text{with } \hat{B} = (T^T T)^{-1} T^T U, \\ \hat{\Theta} &= W(P^T W)^{-1} \hat{B}Q^T. \end{aligned} \quad (25)$$

Notice that if the regression is performed in the outer space, then correlation among columns of Z strongly influence the fitting, while in the case of the inner fitting, the columns of T are orthogonal, therefore fitting B is not affected by the correlation of columns of X .

The deflated data matrices are often computed using the non-linear iterative partial least square (NIPALS) algorithm (Geladi & Kowalski, 1986) or the alternative SIMPLS (de Jong, 1993; Xie & Kalivas, 1997).

3.3. Combination of MRI and PLS

It was stated in the previous paragraphs that MRI ensures a model which is commensurate with MPC criterion (9) and PLS fix the problem of the collinearity. Their combination appears to be a

promising strategy for a building modeling where both requirements should be satisfied.

In this approach the solution proposed by Lauri et al. (2010) which is a combination of numerical optimization and PLS is adapted. The advantage is that it is based on the Taylor expansion reducing thus computation complexity in comparison to other PLS algorithms, e.g. SIMPLS (de Jong, 1993).

Algorithm. Consider a minimization of Eq. (12) approximated by the Taylor expansion

$$\begin{aligned} \hat{J}_{MRI}(\Theta_k + p_k) &= J_{MRI}(\Theta_k) + p_k \frac{\partial J_{MRI}(\Theta_k)}{\partial \Theta_k} + \frac{1}{2} p_k^T \frac{\partial^2 J_{MRI}(\Theta_k)}{\partial \Theta_k^2} p_k, \\ \Theta_{k+1} &= \Theta_k + \alpha_k p_k, \end{aligned} \quad (26)$$

where p_k is the search direction and α_k is the step size. Then

$$\begin{aligned} \hat{J}_{MRI}(\Theta_k + p_k) &= \|Y_a - Z_a(\Theta_k)(\Theta_k + p_k)\|^2 \\ &= \text{tr}(Y_a - Z_a(\Theta_k)(\Theta_k + p_k))^T (Y_a - Z_a(\Theta_k)(\Theta_k + p_k)) \end{aligned} \quad (27)$$

with $\text{tr}(\bullet)$ means the trace of a matrix. An optimal direction and step are obtained as

$$\begin{aligned} \frac{\partial \hat{J}_{MRI}(\Theta_k + p_k)}{\partial (\Theta_k + p_k)} &= 0 \Rightarrow p_k = (Z^T(\Theta_k)Z(\Theta_k))^{-1} Z^T(\Theta_k) Y_a - \Theta_k, \\ \alpha_k &= \arg \min_{\alpha} \hat{J}_{MRI}(\Theta_k + \alpha p_k). \end{aligned} \quad (28)$$

p_k is the direction leading to an optimum (possibly local), while α is a step leading from the local optimum and searching for a possible improvements. The algorithm continues in an iterative sense until the defined stopping condition. Note that solution p_k in Eq. (28) is a solution in an OLS sense, which results in problem in the case of an ill-conditioned regressor and therefore it is replaced by PLS solution from Eq. (25), thus the optimal direction is computed as

$$p_k = W(P^T W)^{-1} \hat{B}Q^T - \hat{\Theta}_k, \quad (29)$$

with respective matrices obtained by applying PLS to Y_a and $Z_a(\Theta_k)$. For discussion on the convergence and numerical aspects, refer to Boyd and Vandenberghe (2004), Potra and Shi (1995) and Moré and Thunert (1994).

4. Case studies

Two case studies are presented here to investigate the properties of the proposed identification method. The first is devoted to a simulation example built in Trnsys and the second one deals with the building of the Czech Technical University (CTU) in Prague (Fig. 4(a)).

For the evaluation of the performance of the developed models a normalized root mean square error (NRMSE) fitness value defined as

$$NRMSE_{fit} = \left(1 - \frac{1}{N} \sum_{k=1}^N \frac{\|y_k - \hat{y}_k\|_2}{\|y_k - E(y_k)\|_2} \right) 100\% \quad (30)$$

is used, where E stands for the expected value operator, y_k and \hat{y}_k are the system and model outputs at time k , respectively.

4.1. Building model constructed in Trnsys

First Trnsys¹ for a construction of a building model is used. This model can be considered as a simulator of a real building because it contains its full physical description. In addition, the number of measured variables is not limited hence more information is available at no additional costs. Subsequently, the input data are fed into the Trnsys model generating thus outputs. These data are then used for identification of a linear time-invariant

¹ www.trnsys.com.

(LTI) model. Finally, the Trnsys model is used for the validation of the LTI model. Trnsys model per se cannot be used in predictive control directly as it is in an implicit form which would require to employ general nonlinear solvers to solve the MPC problem. This, of course, would cause a computational intractability. On the other hand, the LTI model can be readily used in optimization routines.

For the construction of the model in Trnsys, the three building blocks (i) Type56 for a construction of the building, (ii) Type15 for modeling the outside environmental conditions with year weather profile corresponding to Prague, Czech Republic, and finally (iii) Type155 for the communication between Trnsys and Matlab were primarily used. Time-step of the simulation was set to $T_s=15$ min. This time-step guarantees proper convergence of Trnsys internal algorithms.

4.1.1. Description of the building

The constructed building (see a sketch in Fig. 2) is a medium-weight office building. It has a simple structure: two zones with the same area ($5 \times 5 \times 3$ m), each having a window (3.75 m^2) in the south oriented walls. The HVAC system used in the building is TABS (Lehmann, Dorer, & Koschenz, 2007) with a set of pipes in the ceiling distributing supply water. Supply water then performs thermal exchange with the concrete core of the building. The mass flow rate of supply water is constant in both heating circuits which are independent. This means that supply water temperature is the only manipulated variable within the corresponding heating loop.

A 12-state model was developed to investigate the properties of MRI and MRI+PLS (Fig. 3). The model has the following vectors of states and inputs (both manipulated variables and measured disturbances are lumped here) $x^T = [T_{c1}, T_{wall1}, T_{s1}, T_{w1}, T_{n1}, T_{z1}, T_{c2}, T_{wall2}, T_{s2}, T_{e2}, T_{n2}, T_{z2}]$ and $u^T = [T_{sw1}, T_{sw2}, T_o, Q_c, Q_s, Q_w, Q_n, Q_e]$ with meaning of the symbols explained in Tables 1 and 2, respectively. Note that the temperature of each wall except floors together with zones temperatures is measured and considered as states.

4.1.2. Results

The MRI and MRI+PLS algorithms from Section 3 were applied to the data from the Trnsys model. The predictors of the larger model are correlated, i.e. collinearity is present. This fact was used to demonstrate the superiority of MRI+PLS algorithm over MRI when collinearity is present.

The results are summarized in Tables 3 and 4, respectively. Only the results for the output 6 are presented as all the other outputs have very similar contributions. Moreover $n_a = n_b = 2$ was selected, which is in accordance with the physical insight, when most of the heat/temperature transfer functions are of order two. This was also confirmed empirically, when choosing

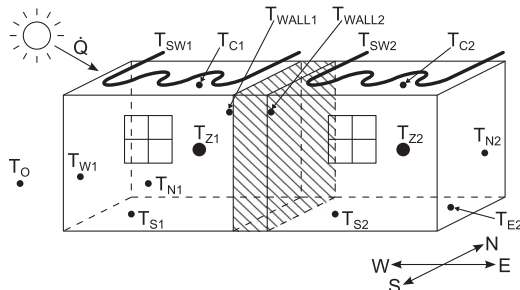

Fig. 2. A scheme of the modeled building

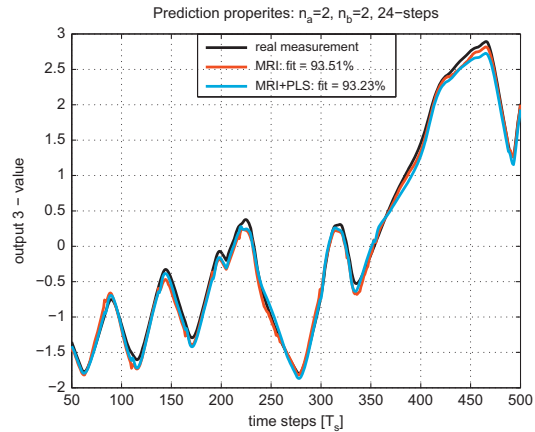

Fig. 3. Comparison of the measured outputs vs. predicted obtained by MRI and MRI+PLS. The data were de-trended for identification purposes, therefore only dynamics of the output without the mean is displayed.

Table 1

Notation of the system inputs and measured disturbances.

Notation	Description
T_{sw1}	Supply water temperature, zone 1
T_{sw2}	Supply water temperature, zone 2
T_o	Ambient temperature
Q_c	Total solar radiation on a horizontal plane
Q_s	Total solar radiation on south side
Q_w	Total solar radiation on west side
Q_n	Total solar radiation on north side
Q_e	Total solar radiation on east side

Table 2

Notation of the system states used in described models.

Notation	Description
T_{c1}	Ceiling core temperature, zone 1
T_{s1}	Core temperature measured on south side, zone 1
T_{w1}	Core temperature measured on west side, zone 1
T_{n1}	Core temperature measured on north side, zone 1
T_{z1}	Zone temperature, zone 1
T_{c2}	Ceiling core temperature, zone 2
T_{s2}	Core temperature measured on south side, zone 2
T_{e2}	Core temperature measured on east side, zone 2
T_{n2}	Core temperature measured on north side, zone 2
T_{z2}	Zone temperature, zone 2
T_{wall1}	Core temperature measured on east side, zone 1
T_{wall2}	Core temperature measured on west side, zone 2

$n_a = n_b = 1$ and $n_a = n_b = 3$ aggravated the results. Similarly, the increase in the prediction horizon P makes the prediction worse. $Model_{pred}$ and its subindex describes the identification method by which the model was obtained as well as the prediction horizon on which the optimization was performed. Of course, model $MRI_{2,4}$ should have the best results on $P=24$, which is indeed true. One of the key factors in the MRI+PLS algorithm is a choice of the number of principal components. The optimal number of the components (30 in our case) was an outcome of the optimization task when MSEF as defined by Eq. (22) was minimized. As can be seen from Table 4, when a lower than optimal number of the components is selected, the model quality defined by NRMSE

of Eq. (30) decreases. As assumed, the MRI+PLS indeed performed better than MRI for the model with correlated predictors.

4.2. Building of the Czech Technical University in Prague

The second example presents a case of the real application, the CTU building in Prague, see Fig. 4(a). The control task is relatively simple as the only controlled quantities supply waters to the heating circuits. The MPC was implemented and operating on the building for more than two years and recorded over 20% average yearly cost savings comparing to the tuned conventional controller (Široký et al., 2011). These results could be even better provided a model optimized on the horizon which commensurate with control horizon.

4.2.1. Description of the building

The CTU building uses Crittall type (Crittall & Musgrave, 1927) ceiling radiant heating and cooling system, where the heating and cooling beams are embedded into the concrete ceiling. For a simple scheme of the heating system refer to Fig. 5. Heating water is supplied by a vapor–liquid heat exchanger to the container where the mixing occurs. An accurate control of the heating water temperature for the respective circuits is achieved by a three-port valve with a servo drive. Heating water is then supplied to the respective ceiling beams. Every circuit has a reference room with a measurement point. The set-point of the control valve is therefore a manipulated variable for the ceiling radiant heating system in each circuit. Because of these reasons, the same control action

is carried out for the entire building block represented as a south or north room in Fig. 4(b).

4.2.2. Model under investigation

The simplified scheme of one building block consists of the ambient temperature predictions, heating water temperature, return water temperature (both in the corresponding heating circuit), reference room temperature and solar radiation. The vector of the inputs contains the ambient temperature, solar radiation and the heating water temperature for south and north oriented zones, i.e. four inputs in total. The outputs are return water temperatures for both zones and reference room temperatures, i.e. four measured outputs in total. The data sets used for identification and consequent validation were processed and resampled with $T_s=30$ min.

4.2.3. Results

Both approaches MRI and MRI+PLS as introduced in Section 3 were applied to data gathered from the CTU building. The data are low-excited and suffer from many problems typical for real-life applications such as missing values, outliers, etc. and collinearity is present as well. This is caused by the fact that supply waters for the respective control loops have very similar temperatures.

The results are computed in-line with the previous example, that is, several models (column $model_{pred}$) were created, where the lower index means the horizon on which the model was optimized. Next the number of steps in prediction horizon (note, however, that the sampling period was increased) was lowered due to the computational complexity of the procedures.

For the results of MRI and MRI+PLS refer to Tables 5 and 6, respectively. It can be seen that MRI+PLS improves the $NRMSE_{fit}$ in compare to MRI. Note also that results for $n_a = n_b = 1$ and $n_a = n_b = 3$ were outperformed by those for $n_a = n_b = 2$ which is in accordance with physical reality as discussed in the previous paragraphs.

Note that Fig. 6 displays south room, while 5 and 6 contain information from the north room.

Table 3
MRI: 12-state model, the model quality is evaluated using $MRSE_{fit}$ from Eq. (30), $n_a=2$, $n_b=2$.

$Model_{pred}$	$P=1$	$P=24$	$P=48$
MRI ₁	99.83	92.59	87.72
MRI ₂₄	99.73	93.74	88.41
MRI ₄₈	99.70	93.25	88.94

Table 4
MRI+PLS: 12-state model, the model quality is evaluated using $MRSE_{fit}$ from Eq. (30), $n_a=2$, $n_b=2$.

$Model_{pred}$	$npc=20$			$npc=30$		
	$P=1$	$P=24$	$P=48$	$P=1$	$P=24$	$P=48$
MRI+PLS ₁	97.08	78.95	70.8	99.76	94.17	89.55
MRI+PLS ₂₄	97.02	79.48	70.88	99.78	94.05	89.77
MRI+PLS ₄₈	96.96	78.04	68.28	99.78	94.56	90.94

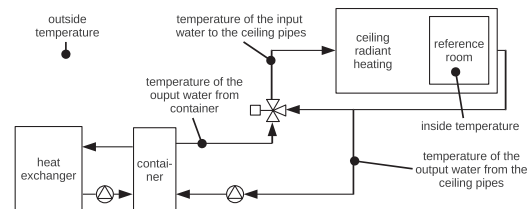

Fig. 5. Simplified scheme of the ceiling radiant heating system.

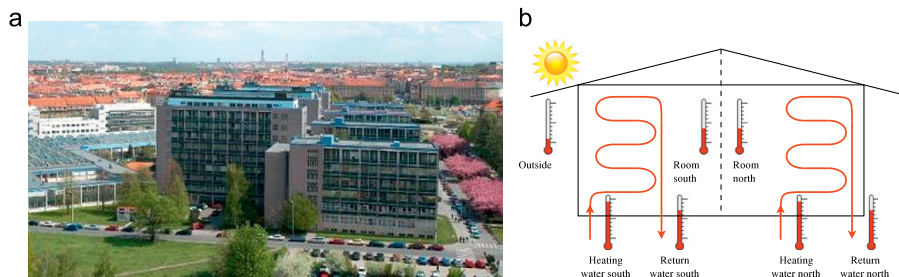

Fig. 4. The building of the CTU in Prague, Faculty of Electrical Engineering and Faculty of Mechanical Engineering. (a) Photo of the building under investigation. (b) Simplified scheme for the identification setup.

Table 5

MRI: CTU building, results are computed by Eq. (30).

$model_{pred}$	$n_a=1, n_b=1$			$n_a=2, n_b=2$		
	$P=1$	$P=12$	$P=24$	$P=1$	$P=12$	$P=24$
MRI ₁	95.85	60.22	53.46	97.64	70.31	62.62
MRI ₁₂	95.31	60.64	57.82	94.38	68.12	64.63
MRI ₂₄	89.39	59.11	55.17	92.00	68.56	65.17

Table 6

MRI+PLS: CTU building, results are computed by Eq. (30).

$Model_{pred}$	$n_a=1, n_b=1$			$n_a=2, n_b=2$		
	$P=1$	$P=12$	$P=24$	$P=1$	$P=12$	$P=24$
MRI+PLS ₁	95.51	60.55	52.87	94.83	71.96	67.72
MRI+PLS ₁₂	94.79	59.29	58.15	94.78	71.61	67.9
MRI+PLS ₂₄	88.01	61.28	55.71	94.57	71.37	68.02

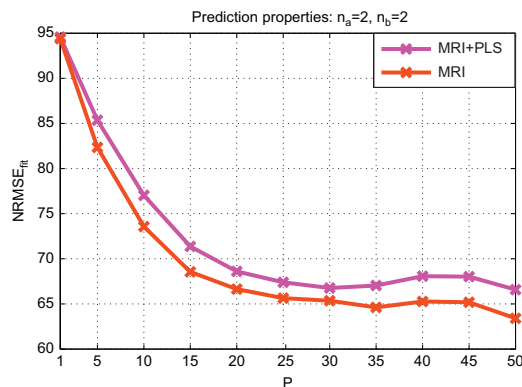
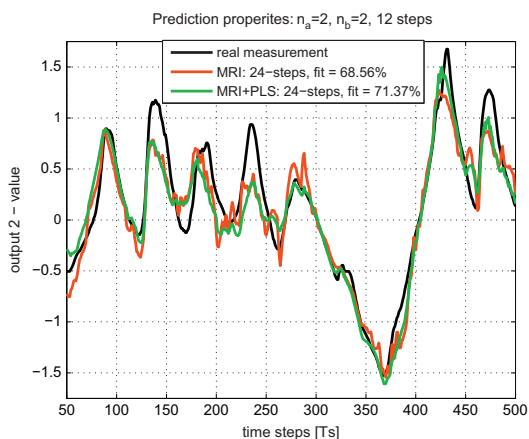
**Fig. 6.** Results for identification by MRI and MRI+PLS for different prediction horizons. Note that model was optimized on 24 steps with $n_a = n_b = 2$.**Fig. 7.** Comparison of the measured outputs vs. predicted obtained by MRI and MRI+PLS, output in south zone. The data were de-trended for identification purposes, therefore only dynamics of the output without the mean is displayed.

A comparison of measured and predicted outputs by MRI and MRI+PLS is displayed for south room in Fig. 7. The dependence of the model quality on the prediction horizon was computed as well. It can be seen that even for very large horizons (50 steps, 30 min per step) the model quality expressed by NRMSE is high.

5. Concluding remarks

It was mentioned in the paper that applying the MPC for control of the HVAC system of the CTU building improved the energy consumption during the last heating seasons by approximately 20%. The control strategy utilized the model obtained by optimizing one-step ahead predictions. In this paper it was argued that the optimization of a model on the horizon that commensurate with the control horizon provides a better results than a standard one-step ahead optimization techniques. Moreover, the novel algorithm for building modeling was proposed. The algorithm named MRI+PLS combines the advantages of the minimization of the multi-step ahead errors and a robust estimation using partial least squares. Finally, two case study examples were provided, the model built in Trnsys and the real building of the CTU in Prague. It was showed that MRI+PLS outperformed MRI in cases where the collinearity is present, otherwise the results are similar. Both MRI and MRI+PLS improved the model quality in compare to the model obtained by the standard one-step ahead minimization.

The next step will be the application of the MPC to the model obtained by MRI+PLS. This will, or course, include the investigation of the energy savings thanks to the improved modeling.

Acknowledgments

The project has been supported by the grant of the Grant Agency of Czech Republic (GACR) no. P103/12/1187.

References

- Andersen, K., Madsen, H., & Hansen, L. (2000). Modelling the heat dynamics of a building using stochastic differential equations. *Energy and Buildings*, 31(1), 13–24.
- Bacher, P., & Madsen, H. (2011). Identifying suitable models for the heat dynamics of buildings. *Energy and Buildings*, 43(7), 1511–1522.
- Bars, R., Colaneri, P., De Souza, C., Dugard, L., Allgöwer, F., Kleimenov, A., et al. (2006). Theory, algorithms and technology in the design of control systems. *Annual Reviews in Control*, 30(1), 19–30.
- Bohlin, T., & Graebe, S. (2007). Issues in nonlinear stochastic grey box identification. *International Journal of Adaptive Control and Signal Processing*, 9(6), 465–490.
- Boyd, S., & Vandenberghe, L. (2004). *Convex optimization*. Cambridge University Press.
- Bull, R., Chang, N., & Fleming, P. (2012). The use of building energy certificates to reduce energy consumption in European public buildings. *Energy and Buildings*, 50(0), 103–110.
- Cigler, J., Privara, S., Váňa, Z., Žáteková, E., & Ferkl, L. (2012). Optimization of predicted mean vote index within model predictive control framework: *Computationally tractable solution*. *Energy and Buildings*, 52(0), 39–49.
- Crittall, R., & Musgrave, J. (April 1927). Heating and cooling of buildings. GB Patent No. 210880.
- Dascalaki, E., Droutsas, K., Gaglia, A., Kontoyiannidis, S., & Balaras, C. (2010). Data collection and analysis of the building stock and its energy performance—an example for hellenic buildings. *Energy and Buildings*, 42(8), 1231–1237.
- de Jong, S. (1993). SIMPLS: An alternative approach to partial least squares regression. *Chemometrics and Intelligent Laboratory Systems*, 18(3), 251–263.
- Ekins, P., & Lees, E. (2008). The impact of eu policies on energy use in and the evolution of the uk built environment. *Energy Policy*, 36(12), 4580–4583.
- Farrar, D., & Glauber, R. (1967). Multicollinearity in regression analysis: The problem revisited. *Review of Economics and Statistics*, 49(1), 92–107.
- Ferkl, L., & Široký, J. (2010). Ceiling radiant cooling: Comparison of ARMAX and subspace identification modelling methods. *Building and Environment*, 45(1), 205–212.
- Geladi, P., & Kowalski, B. (1986). Partial least-squares regression: A tutorial. *Analytica Chimica Acta*, 185, 1–17.

- Gevers, M. (2002). A decade of progress in iterative process control design: From theory to practice. *Journal of Process Control*, 12(4), 519–531.
- Gopaluni, R., Patwardhan, R., & Shah, S. (2002). Bias distribution in MPC relevant identification. In *Proceedings of IFAC world congress*, Barcelona, Citeseer, pp. 2196–2201.
- Gopaluni, R., Patwardhan, R., & Shah, S. (2004). MPC relevant identification—Tuning the noise model. *Journal of Process Control*, 14(6), 699–714.
- Gyalistras, D., & Gwerder, M. (Eds.). (2009). Use of weather and occupancy forecasts for optimal building climate control (opticontrol): Two years progress report. Technical Report, ETH Zurich, Switzerland and Siemens Building Technologies Division, Siemens Switzerland Ltd., Zug, Switzerland.
- Gyalistras, D., Gwerder, M., Oldewurtel, F., Jones, C., Morari, M., Lehmann, B., et al. (2010). Analysis of energy savings potentials for integrated room automation. In *10th REHVA World Congress Clima*.
- Hjalmarsson, H. (2009). System identification of complex and structured systems. *European Journal of Control*, 15(3–4), 275–310.
- Höskuldsson, A. (1988). PLS regression methods. *Journal of Chemometrics*, 2(3), 211–228.
- Jimenez, M., Madsen, H., & Andersen, K. (2008). Identification of the main thermal characteristics of building components using MATLAB. *Building and Environment*, 43(2), 170–180.
- Kiers, H., & Smilde, A. (2007). A comparison of various methods for multivariate regression with highly collinear variables. *Statistical Methods & Applications*, 16(2), 193–228.
- Lauri, D., Martínez, M., Salcedo, J., & Sanchis, J. (2010). PLS-based model predictive control relevant identification: PLS-PH algorithm. *Chemometrics and Intelligent Laboratory Systems*, 100(2), 118–126.
- Laustsen, J. (2008). Energy efficiency requirements in building codes, energy efficiency policies for new buildings. International Energy Agency and OECD.
- Lehmann, B., Dorer, V., & Koschensch, M. (2007). Application range of thermally activated building systems tabs. *Energy and buildings*, 39(5), 593–598.
- Levermore, G. (1992). Building energy management systems: An application to heating and control. E & FN Spon.
- Ljung, L. (1999). System identification: Theory for user. Prentice-Hall, Inc., Upper Saddle River, NJ, USA.
- Lodi, C., Bacher, P., Cipriano, J., & Madsen, H. (2012). Modelling the heat dynamics of a monitored test reference environment for building integrated photovoltaic systems using stochastic differential equations. *Energy and Buildings*, 50(0), 273–281.
- Lukasse, L., van Maldegem, J., Dierkes, E., van der Voort, A.-J., de Kramer-Cuppen, J., & van der Kolk, G. (2009). Optimal control of indoor climate in agricultural storage facilities for potatoes and onions. *Control Engineering Practice*, 17(9), 1044–1052.
- Ma, Y., Borrelli, F., Henceny, B., Coffey, B., Bengesa, S., & Haves, P. (2011). Model predictive control for the operation of building cooling systems. *IEEE Transactions on Control Systems Technology*(99), 1–8.
- Maciejowski, J. (2001). *Predictive control with constraints*. Prentice-Hall.
- Mason, C., & Perreault, W., Jr. (1991). Collinearity, power, and interpretation of multiple regression analysis. *Journal of Marketing Research*, 268–280.
- Metz, B. (2007). *Climate change 2007: Mitigation of climate change: Contribution of Working Group III to the Fourth Assessment Report of the Intergovernmental Panel on Climate Change*. Cambridge University Press.
- Moré, J., & Thunent, D. (1994). Line search algorithms with guaranteed sufficient decrease. *ACM Transactions on Mathematical Software (TOMS)*, 20(3), 286–307.
- Oldewurtel, F., Parisio, A., Jones, C., Morari, M., Gyalistras, D., Gwerder, M., et al. (2010). Energy efficient building climate control using stochastic model predictive control and weather predictions. In *American Control Conference (ACC)* (pp. 5100–5105).
- Pérez-Lombard, L., Ortiz, J., & Pout, C. (2008). A review on buildings energy consumption information. *Energy and Buildings*, 40(3), 394–398.
- Potra, F., & Shi, Y. (1995). Efficient line search algorithm for unconstrained optimization. *Journal of Optimization Theory and Applications*, 85(3), 677–704.
- Privara, S., Široký, J., Ferkl, L., & Cigler, J. (2011). Model predictive control of a building heating system: The first experience. *Energy and Buildings*, 43(2–3), 564–572.
- Privara, S., Váňa, Z., Žáčková, E., Cigler, J. Building Modeling: Selection of the Most Appropriate Model for Predictive Control, *Energy and Buildings* (2012) <http://dx.doi.org/10.1016/j.enbuild.2012.08.040>.
- Richalet, J., Rault, A., Testud, J., & Papon, J. (1978). Model heuristic predictive control. *Automatica*, 14, 413–428.
- Rivera, D., Pollard, I., & Garcia, C. (1992). Controlrelevant prefiltering: A systematic design approach and case study. *IEEE Transactions on Automatic Control*, 37(7), 964–974.
- Shook, D., Mohtadi, C., & Shah, S. (2002). A control-relevant identification strategy for GPC. *IEEE Transactions on Automatic Control*, 37(7), 975–980.
- Stone, M., & Brooks, R. (1990). Continuum regression: Cross-validated sequentially constructed prediction embracing ordinary least squares, partial least squares and principal components regression. *Journal of the Royal Statistical Society. Series B (Methodological)*, 237–269.
- Tashtoush, B., Molhim, M., & Al-Rousan, M. (2005). Dynamic model of an HVAC system for control analysis. *Energy*, 30(10), 1729–1745.
- Van Overschee, P., & De Moor, B. (1999). Subspace identification for linear systems. Kluwer Academic Publishers, 101 Philip Drive, Assinippi Park, Nowell, Massachusetts.
- Váňa, Z., & Preisig, H. A. (2012). System identification in frequency domain using wavelets: Conceptual remarks. *Systems Control Letters*, 61(10), 1041–1051.
- Široký, J., Oldewurtel, F., Cigler, J., & Privara, S. (2011). Experimental analysis of model predictive control for an energy efficient building heating system. *Applied Energy*, 88(9), 3079–3087.
- Wang, S., & Xu, X. (2006). Simplified building model for transient thermal performance estimation using GA-based parameter identification. *International Journal of Thermal Sciences*, 45(4), 419–432.
- Xie, Y., & Kalivas, J. (1997). Evaluation of principal component selection methods to form a global prediction model by principal component regression. *Analytica Chimica Acta*, 348(1–3), 19–27.
- Žáčková, E., Privara, S., & Váňa, Z. (2011). Model predictive control relevant identification using partial least squares for building modeling. In *Australian Control Conference (AUCC)*, 2011. IEEE (pp. 422–427).
- Zhu, Y. (2001). *Multivariable system identification for process control*. Elsevier.

3.3 SELECTION OF THE MOST APPROPRIATE MODEL FOR PREDICTIVE CONTROL

Energy and Buildings paper entitled *Building Modeling: Selection of the Most Appropriate Model for Predictive Control* treats the problem of selection of the best model for subsequent predictive control as well as the statistical validation of the selected model.

The presented approach is iterative having two stages. In the first stage, a minimum set of disturbance inputs is formed so that the resulting model is the best with respect to a defined quality criterion; then the second stage comprises addition of the states to obtain the final minimum set of states maximizing the model quality. The procedure stops when it makes no sense to select more complex model as it brings no more quality improvements. The residuals of the selected model are statistically evaluated against expected white noise.

Finally, a case study is provided where the above mentioned approach is investigated and tested.

The share of the author on the result according to VVVS is 50%.

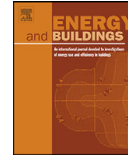

Building modeling: Selection of the most appropriate model for predictive control

Samuel Prívvara*, Zdeněk Váňa, Eva Žáčková, Jiří Cigler

Department of Control Engineering, Faculty of Electrical Engineering, Czech Technical University in Prague, Czech Republic

ARTICLE INFO

Article history:

Received 24 March 2012

Received in revised form 22 August 2012

Accepted 26 August 2012

Keywords:

Building modeling and identification

Model selection

Statistical tests

Model complexity

ABSTRACT

Model predictive control has become a widespread solution in many industrial applications and is gaining ground in the field of energy management and automation systems of buildings. A model with reasonable prediction properties is an ultimate condition for good performance of the predictive controller.

This paper presents an approach in which a model of a building is selected by an iterative two stage procedure. In the first stage, a minimum set of disturbance inputs is formed so that the resulting model is the best with respect to a defined quality criterion; then the second stage comprises addition of the states to obtain the final minimum set of states maximizing the model quality. The procedure stops when it makes no sense to select more complex model as it brings no more quality improvements. Statistical tests such as the likelihood ratio test, the tests based on cumulative periodogram, the two-sample Kolmogorov–Smirnov test as well as others (fit factor and coefficient of determination) are used to evaluate the relationship between the addition of inputs/states and the model quality. Three identification approaches, namely model predictive control relevant identification, deterministic semi-physical and probabilistic semi-physical modeling are used for estimation of building parameters.

Finally, a case study is provided where all the above mentioned approaches are investigated and tested.

© 2012 Elsevier B.V. All rights reserved.

1. Introduction

1.1. Use of predictive control in the buildings

Buildings account for huge amount of final energy consumption [1] and there is a growing effort targeted at optimization of its consumption. Apart from the retrofitting and modernizations of the buildings, the cheaper and recently very popular approach for energy consumption optimization is to deploy advanced control algorithms [2].

Model predictive control (MPC) has become a widespread solution in many industrial applications and is gaining ground in the field of building energy management and automation systems. Its growing popularity for the control of building automation systems (BAS) or heating ventilation air conditioning (HVAC) has mirrored in a number of papers dealing with both theory [3–7] and practical applications [2,8,9].

MPC is a modern control technique, which is characterized by its ability to handle constrained optimal control problems. At each

time step, a constrained optimization problem is solved for the current state of the building and the first step of the solution is then applied. This means that at each time step, a plan for heating, cooling or ventilation is computed for the optimization horizon based on predictions of future weather conditions and other disturbances such as occupancy, internal gains, etc. A case study devoted to the MPC control of thermally activated building system (TABS) for a real building is shown in [2]. The energy savings potential, when the MPC with weather predictions for the investigated building heating system was used, were between 15 % and 28 % depending on various factors, mainly the insulation level and outside temperature. This is consistent with results achieved in large scale simulations done in the scope of the Opticontrol project ([10] chapter 8). Thus, there is a great potential to save energy by applying the MPC to the building environment control.

1.2. Building modeling and identification

As the identification of the model suitable for MPC is the bottleneck of the whole procedure, there is an intensive research in the field of a building model identification [11–13]. A possible approach is to use building simulation programs such as Trnsys, EnergyPlus (EP), ESP-r, etc., but these models are not explicit and thus cannot be used for control directly. Alternatively, there are basically these modeling and identification approaches that can be used for buildings.

* Corresponding author at: Department of Control Engineering, Faculty of Electrical Engineering, Czech Technical University in Prague, Technická 2, 166 27 Praha 6, Czech Republic. Tel.: +420 776 697 672.

E-mail addresses: samuel.privara@fel.cvut.cz (S. Prívvara), zdenek.vana@fel.cvut.cz (Z. Váňa), zacekova@fel.cvut.cz (E. Žáčková), jiri.cigler@fel.cvut.cz (J. Cigler).

- Probabilistic semi-physical modeling (PSPM) [14,15] is an approach utilizing maximization of the likelihood function in order to estimate parameters of the predefined physical description of a stochastic process.
- Deterministic semi-physical modeling (DSPM) [2,16–18] uses resistance capacitance (RC) network analogue to an electric circuit to describe the dynamics of a process.
- Subspace identification method (4SID) [9,19] is an example of a black box identification approach, when there is no or very limited knowledge of the system structure. The system is identified in a purely statistical manner.
- MPC relevant identification (MRI) [11] is a method when a multi-step ahead prediction error is minimized over the same horizon as used for the predictive control.

Note that PSPM, DSPM and MRI belong to the group of grey box modeling approaches. In this case, the internal workings in the physical system are partially known but the full (exact, complete) information is not required. By contrast, the black box techniques rely on the measured data only which are then processed by statistical identification; the internal workings are not reflected, therefore a user must provide the data with certain quality of excitation to acquire valid results [20].

1.3. Objective of the paper

As was noted above, the MPC proved to have a significant savings potential. On the other hand, it depends on the quality of the model used for optimization. Low-quality models eliminate much of its saving potential. The high quality models tend to be quite complex which brings problems of computational tractability and the loss of physical insight.

Therefore, it is certainly desirable to have a model of the least possible complexity, though still having the required quality. The objective of this paper is to find a method to construct a model which has the smallest input and parameter sets possible, has good prediction properties and, moreover, is in accordance with the physical reality.

Note that the whole paper deals with the energy savings resulting from better modeling. For savings thanks to control, refer e.g. to [2].

1.4. Scope of the paper

Usually, there is a number of models at hand and the task is to select the best model suitable for predictive control. In case of static models, the solution is standardized and well-established, however in dynamical models, especially those multiple-input multiple-output (MIMO), it is a demanding task.

We present here an approach for the systematic building-up of a model through a growing model complexity. This work follows the previous papers by [14–16,21]. In these papers an approach using the maximization of the likelihood for identification of the parameters and the likelihood ratio criterion for model selection was introduced. We extend this approach to several identification methods. Moreover, not only the relationship between increasing number of parameters and model quality, but the selection of the disturbance inputs are considered. In our approach we present a two stage selection procedure. In the first stage, a minimum set of disturbance inputs maximizing the model quality is selected and then, for the given set of inputs, the minimum set of states using the same logic as in the previous stage is selected. Such a procedure can have a significant technical and economical impact, as the model resulting from this procedure is of much lower complexity than the full model (model with the full set of disturbance inputs and all the system states) but is of a comparable quality. As a result,

the consequent MPC optimization problem is computationally less demanding, which is, especially for large systems such as office buildings, very important. Moreover, less states and disturbance inputs mean less sensors, which, in cases that some disturbances are very difficult to measure (internal gains, presence of occupants), or others being provided as a service (e.g. weather forecasts for building climate control) leads to significant financial savings.

In this study, a building model in the simulation software Trnsys is used to test the proposed building identification procedure. Moreover, in contrast to a real building, the length of measured/generated signals is not limited (technically or economically) and, therefore, more information is available at no additional cost. It is thus possible to verify which set of signals is necessary for obtaining the certain quality of the resulting model for control.

1.5. Structure of the paper

The following section provides the overview of identification and modeling approaches suitable for predictive control of buildings as well as discusses the pros and cons for each of them. Two stage procedure for model selection and model validation is described in Section 3. The case study in Section 4 presents the application of selected identification and modeling approaches and evaluates their performance. Finally, the last section concludes the paper.

2. Building identification and modeling approaches

Even though there is a large number of modeling and identification approaches developed over the years, not all of them are suitable for the building modeling. Moreover, one cannot say that a single strategy is the best for all the instances. Grey box models provide a way of combining the advantages of both white box models and black box models [20,21] that is, they form a natural framework for modeling of dynamical systems. On the other hand, the physical structure of the process is not always known or the system is too large, thus the grey box modeling cannot be used and statistically based methods are more appropriate [19,22]. Identification approaches resulting in a linear model suitable for the MPC are listed below.

2.1. Subspace identification algorithm

Subspace state-space algorithm (4SID) [23] is a very popular choice when there is no information about the system structure. This algorithm uses state-space structure

$$\begin{aligned}x_{k+1} &= Ax_k + Bu_k + Ke_k, \\y_k &= Cx_k + Du_k + e_k,\end{aligned}\tag{1}$$

e_k is zero mean Gaussian white noise, $x_k \in \mathbb{R}^n$ is the state vector, $u_k \in \mathbb{R}^m$ is the input vector, $y_k \in \mathbb{R}^l$ is the output vector with k denoting the discrete time, and A, B, C, D, K stand for the system matrices. It can provide the estimate of the system order as well as matrices of the state-space description [24]. In case of large data sets and/or a complex structure, when other algorithms suffer from computational problems, 4SID is a very suitable candidate. On the other hand, its greatest advantage, black box approach, is also its greatest weakness as it often spoils the true system structure and only the input-output behavior is satisfactory, while the internal behavior depending on the system structure is misleading. This can be partly fixed by the incorporation of prior information [25–27], however these approaches do not work for general case.

2.2. Probabilistic semi-physical modeling

Having a physical description of the system, it is possible to estimate the model parameters directly from stochastic differential equations e.g. by using the maximum likelihood (ML) estimation including the prior knowledge of system parameters. Then the estimation problem can be expressed as

$$\theta_{ML}^* = \underset{\theta}{\operatorname{argmax}} \{\ln(L(\theta, Y_1^N | y_0))\}, \quad (2)$$

$$L(\theta, Y_1^N | y_0) = \prod_{k=1}^N \frac{\exp(-\varepsilon_k^T R_{k|k-1}^{-1} \varepsilon_k / 2)}{(\sqrt{2\pi})^l \sqrt{\det(R_{k|k-1})}} p(y_0 | \theta), \quad (3)$$

where L is the likelihood function, Y_1^N stands for N measurements, y_0 are the initial conditions, l is a dimension of the problem (number of outputs), θ is the vector of unknown parameters, $p(y_0 | \theta)$ is the conditional probability of initial conditions on parameters, ε_k are residuals and $R_{k|k-1}$ is the residual covariance matrix. The problem can be solved only in an iterative manner, when ε_k and $R_{k|k-1}$ are computed given the estimate $\hat{\theta}$ of θ . However, to compute $\hat{\theta}$, the knowledge of the noise properties must be assumed. The estimation of both parameters and covariance matrix is performed using the EM algorithm [28,29]. An alternative procedure for estimating the covariance by means of the Kalman filter in a recursive manner is implemented in CTSM software [21]. The biggest bottleneck of this approach is its high computational demand, therefore it is suitable only for smaller data sets and/or models of the lower complexity.

2.3. Deterministic semi-physical modeling

In many cases, it is sufficient to model a building in a deterministic fashion. The very simple, though effective method [16] is presented in the following. This method uses least squares (LS) for solving the parameter estimation problem. It starts with the discretization of the original continuous-time linear system, e.g. as

$$A = e^{A_c T_s} = I + A_c T_s + \frac{A_c^2 T_s^2}{2} + \dots \approx I + A_c T_s, \quad (4)$$

$$B = \int_0^{T_s} e^{A_c \tau} d\tau \approx \int_0^{T_s} I d\tau B_c = T_s B_c,$$

where A_c , B_c and A , B are model matrices of continuous- and discrete-time models, respectively. T_s stands for sampling time. This corresponds to the Euler's discretization, thus can be applied for the non-linear systems as well. Then the state equation can be written as

$$X_1^N = AX_0^{N-1} + BU_0^{N-1} + E_0^{N-1} = \quad (5)$$

$$= \begin{bmatrix} A & B \end{bmatrix} \begin{bmatrix} X_0^{N-1} \\ U_0^{N-1} \end{bmatrix} + E_0^{N-1}, \quad (5)$$

with $N+1$ being the number of samples and X_1^N , X_0^{N-1} , U_0^{N-1} and E_0^{N-1} defined similarly as in Section 2.2. The state equation (5) can be rewritten to the LS estimation problem with the aid of vectorization ($\operatorname{vec} \bullet$) and the Kronecker product ($\bullet \otimes \bullet$)

$$\operatorname{vec} X_1^N = \left(\begin{bmatrix} X_0^{N-1} \\ U_0^{N-1} \end{bmatrix} \otimes I_n \right)^T \operatorname{vec} \begin{bmatrix} A & B \end{bmatrix} + \operatorname{vec} E_0^{N-1},$$

with I_n being $n \times n$ identity matrix, n represents system order. Extra lines for preserving the structure of A and B as well as other required constraints can be added into the regressor and left-hand side matrices. The unknown parameters are then estimated using the weighted LS or arbitrary quadratic programming solver.

2.4. MPC relevant identification

One of the most important criteria for the selection of the modeling and identification approach is the purpose of the constructed model. If the purpose is predictive control, the performance of the model over the prediction horizon is of the highest concern, thus the minimization of the prediction error over the prediction horizon plays a major role.

The prediction error method (PEM) [30] optimizes model prediction properties over a single step ahead only. The MPC however, needs satisfactory predictions over the whole prediction horizon, hence a model intended for use within the MPC framework should primarily be a good multi-step ahead predictor. Such methods, minimizing the multi-step ahead prediction error, are collectively called MPC relevant identification (MRI) methods [11,31–34]. This problem is addressed in detail in the following.

For minimization of the multi-step ahead prediction error, the following criterion is considered

$$J_{MRI} = \sum_{k=0}^{N-P} \sum_{i=1}^P (y_{k+i} - \hat{y}_{k+i|k})^2, \quad (6)$$

where $\hat{y}_{k+i|k}$ is the i -step ahead output prediction constructed from data up to time k , $N+1$ is the number of samples and P is the prediction horizon for identification.

In the elementary case of the single-input and single-output AutoRegressive eXternal Input (ARX) model, the multi-step output prediction $\hat{y}_{k+i|k}$ is expressed as a multiplication of the regressor Z and the vector of the unknown parameters $\hat{\theta}$:

$$\hat{y}_{k+i|k} = Z_{k+i} \hat{\theta}, \quad i = 1, \dots, P, \quad (7)$$

where $\hat{\theta} = [\hat{b}_{n_d}, \dots, \hat{b}_{n_b}, \hat{a}_1, \dots, \hat{a}_{n_a}]^T$ and regressor $Z(q) = [u_{q-n_d}, \dots, u_{q-n_b}, y_{q-1}, \dots, y_{q-n_a}]$ with $q = k+i$. n_a and n_b denote the number of the delayed inputs and outputs in the regressor, respectively, and n_d represents the delay of the outputs compared to the inputs ($n_d = 0$ means the direct input–output connection). Every output y_a in Z_{k+i} with $a > k$ is not available at the actual time k , therefore an output prediction $\hat{y}_{a|k}$ must be obtained. To acquire the prediction, the following expression is applied i -times

$$\hat{y}_{k+1|k} = Z_{k+1} \hat{\theta}. \quad (8)$$

Obviously, $k \geq \max(n_a, n_b)$. The recursion starts with the current output y_k . Then the optimal values of the coefficients of the deterministic part of the system contained in the unknown vector θ can be acquired by solving the following non-linear optimization task

$$\theta^* = \underset{\hat{\theta}}{\operatorname{argmin}} \sum_{i=1}^P \sum_{k=0}^{N-i} (y_{k+i} - Z_{k+i} \hat{\theta})^2. \quad (9)$$

The MRIs provide models with very good prediction properties over the optimized horizon [11]. Unfortunately, they suffer from computational complexity as they employ non-linear numerical optimization algorithms and provide results in a reasonable time only for simpler model structures such as ARX or some cases of AutoRegressive Moving Average with eXternal input (ARMAX).

3. Model selection and validation

Selection of an appropriate model for predictive control is addressed in this section. First, a two stage procedure is described in detail and then, criteria for model performance evaluation and model selection are provided. Additionally, the models selected for further investigation are validated using standard assumptions on the residuals [35].

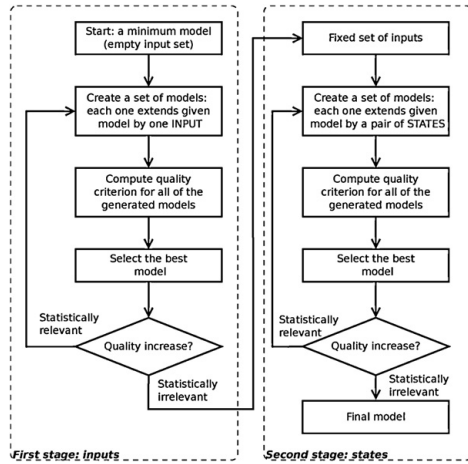

Fig. 1. Two stage model selection procedure.

3.1. Two stage model selection procedure

In case that model candidates of a different complexity (in sense of the number of disturbance inputs and states) are at hand, the question naturally arises, how to select the more appropriate model. The proposed selection procedure comprises the following stages (see Fig. 1). First, the minimum set of (disturbance) inputs maximizing the model quality is selected and then, given the fixed set of inputs, the same routine is performed to select the minimum set of the system states. Both stages are performed iteratively, when the necessity of the subsequent iteration is decided by a result of a statistical test applied to a chosen criterion. The respective stages are described in the following.

3.1.1. Selection of the disturbance inputs

The set of the selected inputs is initialized, it contains all the control inputs and no disturbance inputs. In the first iteration, s models are constructed. Each of them contains all the inputs from the set of selected inputs (i.e. all the control inputs) and one of the s disturbance inputs, that is, as many models as disturbance inputs available are created. Afterwards, the quality criterion is computed for all the models. The disturbance input corresponding to the model with the highest value of the chosen quality criterion is added to the set of the selected inputs. In the next iteration, $s - 1$ new models are created. Each of them contains the set of selected inputs (i.e. all the control and disturbance inputs from the previous iteration) and one of the $s - 1$ remaining disturbance inputs. Again, the quality criterion of all models is evaluated and the best one is selected. The iterations continue using the same logic. If the increase¹ of the model quality due to the additional input is not significant in a statistical sense, the iterations stop and the first stage is completed resulting to the fixed set of inputs.

3.1.2. Selection of the system states

Next, for the fixed set of the inputs, the minimum set of the system states maximizing the model quality is found in a similar way as was done for the inputs.

¹ The quality of the model under consideration is compared to the full model, i.e. the model is tested against the hypothesis that the model under consideration is a good representative of the full model.

Note that this procedure is possible only for the cases when a full complexity model is known. That means that the model with the highest value of a criterion is statistically tested against the full model in each iteration. An alternative procedure, applicable even in the situation when the full complexity model is not available, has a different principle. In each iteration, the model under consideration is statistically tested against the model from the previous iteration. That is, there are far more iterations than in the procedure proposed in this paper, however, the results of both procedures are always the same. A variety of criteria considered for the quality evaluation and testing are treated in detail in the following.

3.2. Criteria for model selection

Different system parameter estimation techniques require different criteria for model selection. For parameters obtained by CTSM, a ML estimate given by Eq. (2) offers three statistical tests, namely the likelihood ratio test (LRT), the Wald test (WT) and the Lagrange multipliers test (LMT). When using the LMT, the question is what parameters (if any) should be added to improve the performance of the model, while in case of the WT the task is the exact contrary, i.e. having the more complex model, the objective is to test if there are any parameters of those currently used which could be set to zero without significantly worsening the model performance. In this paper the LRT will be examined and is discussed in the following paragraph.

For the evaluation of the quality increase in case of models obtained by DSPM and MRI, a different approach is adopted. For the purposes of this paper the T -criterion based on the cumulative periodogram has been developed and is used alongside with the similar two-sample Kolmogorov-Smirnov (KS) test. The main difference is that the KS is based on infinity norm, while the T -test is proportional to 2-norm.

3.2.1. Likelihood ratio test

The basic idea of the the LRT is to compare the amount of information contained in the sub-model (restricted model) and the (unrestricted) model itself. If the performance of the more complex model is not significantly (in a statistical sense) better, it is possible to use the submodel. LRT is defined as

$$\lambda(Y_1^N) = \frac{\max_{\theta_0 \in \Theta_0} L(\theta_0, Y_1^N)}{\max_{\theta \in \Theta} L(\theta, Y_1^N)}, \quad (10)$$

where $\theta_0 \in \Theta_0$ are the parameters of the submodel, r is the number of parameters of the full model and c is a number of parameters of the submodel, i.e. $\dim(\Theta_0) = c$, $\dim(\Theta) = r$. Then, under the hypothesis $H_0 : \theta_0 \in \Theta_0$, the test statistics can be expressed as $-2 \ln(\lambda(Y_1^N))$ which asymptotically follows $\chi^2(r - c)$. If the corresponding p -value is lower than the selected significance level α , then H_0 is rejected, i.e. the increase in the model quality is still significant and further additions are necessary.

3.2.2. The test based on the cumulative periodogram

This criterion was developed for the purposes of this paper to evaluate the models obtained by the DSPM and MRIs. The cumulative periodogram of a random quantity $x_k : k = 1, \dots, N$ is defined as [36]

$$\hat{F}_x(\omega_j) = \frac{\sum_{i=1}^j \hat{I}_x(\omega_i)}{\sum_{i=1}^s \hat{I}_x(\omega_j)}, \quad j = 1, \dots, s, \quad (11)$$

where $s = (N - 1) / (2)$ and $\hat{I}_x(\omega) = (1 / (2\pi N)) \left| \sum_{k=1}^N x_k e^{-i\omega k} \right|^2$ evaluated at ω of the form $\omega_j = 2\pi j / N$ that is $\omega \in [0, 0.5]$ of Nyquist frequency. Then T-criterion is defined as follows

$$T = \sum_{j=1}^s \min \left\{ \left\| \hat{F}_x(\omega_j) - \left(\hat{F}_{wn}(\omega_j) \pm \frac{1.36}{\sqrt{N/2+1}} \right) \right\| \right\}, \quad (12)$$

where $\hat{F}_{wn}(\omega_j)$ and $\hat{F}_x(\omega_j)$ are values of the periodogram of white noise and the tested residuals at ω_j , respectively; $\frac{1.36}{\sqrt{N/2+1}}$ is the KS statistics corresponding to 5% significance level, N is the number of considered samples. In fact, Eq. (12) corresponds to the sum of distances between the actual periodogram $\hat{F}_x(\omega_j)$ and the permitted range $\hat{F}_{wn} \pm \frac{1.36}{\sqrt{N/2+1}}$ for white noise. Note that Eq. (12) is proportional to the area between two tested functions. $T = 0$, when there is no statistically significant difference between the constrained and the unconstrained model.

Yet another approach, similar to the previous one, performs statistical testing of L_∞ vector norm applied to difference in periodograms. KS two-sample test [37,38] makes use of the normalized cumulative periodogram of residuals and compares it with theoretical cumulative periodogram of white noise.

3.3. Model validation and analysis of residuals

3.3.1. Analysis of the residuals

The validity of the models is examined by testing the residuals for whiteness. Residual autocorrelation (ACF) and partial autocorrelation functions (PACF) [36], AutoRegressive model (AR) and the cumulative periodogram are used for tests of whiteness of residuals. The tests based on the cumulative periodogram were also used for model selection as described in the previous paragraph. The residuals of all the models were tested (i) visually using ACF, PACF and the cumulative periodogram, and (ii) statistically, when the null hypothesis H_0 assumes that the data generator is a zero order AR process (residuals are white sequences) against the hypothesis that the AR process is of a higher order. For details of the test, refer to [39,40].

3.3.2. Model quality criteria

To evaluate a model, the following criteria can be used.

$$FIT_j = 100 \times \left(1 - \frac{\|y_j - \hat{y}_j\|_2}{\|y_j - \varepsilon(y_j)\|_2} \right) [\%], \quad (13)$$

$$R_j^2 = 1 - \frac{var(y_j - \hat{y}_j)}{var(y_j)}, \quad (14)$$

where y_j denotes the j th output of the model, $var(\bullet)$ stands for variance, \hat{y} is the estimate of y and $\varepsilon(y)$ denotes the mean of y . The former defined by Eq. (13) is called fit factor (100% means that even the noise is fully explained by the model. In fact, the fit factor is $1 - NRMSE$, where $NRMSE$ stands for normalized root means square error.), while the latter is the coefficient of determination. Note that Eq. (13) and Eq. (14) are unreliable in case of purely statistically based methods such as the 4SID applied to the estimation of dynamical models intended for control. Even though they have usually a high fit, they do not preserve the physical properties of the system.

4. Case study

As a case study, the two stage selection of the complexity of a building model is presented. First, a description of the building under investigation, a short review of the basic physical processes

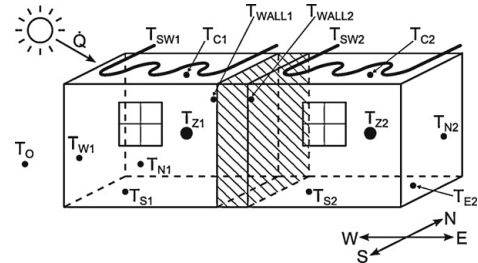

Fig. 2. A scheme of the modeled building.

in the building as well as model formulation are provided (Sections 4.1–4.4). Thereafter, the results of the model complexity selection procedure as well as model verification and validation are presented (Section 4.5).

4.1. Building under investigation

The building under investigation, schematically outlined in Fig. 2, is a medium weight office building with two zones separated by a concrete wall. Both zones have the same dimensions ($5 \text{ m} \times 5 \text{ m} \times 3 \text{ m}$) and the south oriented walls of the zones include a window (3.75 m^2).

The HVAC system used in the building is Thermally Activated Building Systems (TABS) [41]. These systems are radiant hydronic systems embedded in the building structure, which distribute or extract heat from the spaces. In the investigated building, the hydronic system is composed of a long pipe placed in the ceiling distributing supply water, which then performs thermal exchange with the concrete core. The mass flow rate in the pipe is held constant. This building has two independent hydronic circuits, each for one zone.

4.2. Trnsys model of the investigated building

A model of the investigated building was constructed in Trnsys environment². Various components were employed in the modeling of the building (i) Type56 for the building construction, (ii) Outside environmental conditions (involving ambient temperature, outside air relative humidity and solar characteristics) are simulated using Trnsys Type15 with year weather profile corresponding to Prague, Czech Republic, (iii) For purposes of model identification, the link between Trnsys and Matlab was established based on Trnsys Type155. The communication link was used to generate the identification data in order to excite the system properly. The pseudo random binary sequence was used as the excitation input signal.

Note that for a real building, the excitation of the system is a topic which is not treated here. For more details refer to e.g. [19,42]. The time-step of the simulation was set to $T_s = 0.25 \text{ h}$. This time-step guarantees proper convergence of Trnsys internal algorithms and is also suitable for description of important building dynamics.

² Trnsys is an energy simulation software primarily used in the fields of renewable energy and building simulation. For control engineers, a Trnsys model can be used as a data generator for construction of a building model or for validation of control algorithms. The Trnsys model as such cannot be used directly in the optimization, i.e. in predictive control, because the model is in implicit form and thus general nonlinear solvers would have to be utilized, which is computationally intractable.

Table 1
System states, inputs and measured disturbances.

Notation	ID	Description
<i>(a) System inputs and measured disturbances</i>		
T_{sw1}	1	Supply water temperature, zone 1
T_{sw2}	2	Supply water temperature, zone 2
T_o	3	Ambient temperature
\dot{Q}_s	4	Total solar radiation on south side
\dot{Q}_w	5	Total solar radiation on west side
\dot{Q}_n	6	Total solar radiation on north side
\dot{Q}_e	7	Total solar radiation on east side
\dot{Q}_{ds}	8	Direct solar radiation on south side
\dot{Q}_{dw}	9	Direct solar radiation on west side
\dot{Q}_{dn}	10	Direct solar radiation on north side
\dot{Q}_{de}	11	Direct solar radiation on east side
T_{sky}	12	Sky temperature
<i>(b) System states</i>		
T_{c1}	1	Ceiling core temperature, zone 1
T_{wall1}	2	Core temperature of common wall, zone 1
T_{s1}	3	Core temperature on south side, inside, zone 1
T_{w1}	4	Core temperature on west side, inside, zone 1
T_{n1}	5	Core temperature on north side, inside, zone 1
T_{z1}	6	Zone temperature, zone 1
T_{c2}	7	Ceiling core temperature, zone 2
T_{wall2}	8	Core temperature of common wall, zone 2
T_{s2}	9	Core temperature on south side, inside, zone 2
T_{e2}	10	Core temperature on east side, inside, zone 2
T_{n2}	11	Core temperature on north side, inside, zone 2
T_{z2}	12	Zone temperature, zone 2
T_{os1}	13	Core temperature on south side, outside, zone 1
T_{ow1}	14	Core temperature on west side, outside, zone 1
T_{on1}	15	Core temperature on north side, outside, zone 1
T_{os2}	16	Core temperature on south side, outside, zone 2
T_{oe2}	17	Core temperature on east side, outside, zone 2
T_{on2}	18	Core temperature on north side, outside, zone 2

4.3. Heat transfer in a building

To assemble a full detailed first principle model, the following ways of heat transfer are considered.

- Conduction, which can be expressed as $\dot{T}_2 = (T_1 - T_2)/k_{cd}$, represents the heat transfer through a solid body. T_1 and T_2 are the temperatures of a source and a measured entity, respectively; k_{cd}

stands for the conduction constant ($k_{cd} \propto R \cdot C$, R and C denoting the thermal resistance and capacity of the mass). Moreover, the conduction can be expressed as $\dot{T}_2 = \dot{Q}/k'_{cd}$ with \dot{Q} being a heat flux and k'_{cd} modified conduction constant.

- Convection, characterized as $\dot{T}_2 = (T_1 - T_2)/k_{cv} \cdot \sqrt[4]{(T_1 - T_2)/(T_1 + T_2)}$, corresponds to a heat transfer through the air, k_{cv} is a convection constant. It can be approximated by $\dot{T}_2 \approx (T_1 - T_2)/k'_{cv}$ as $\sqrt[4]{(T_1 - T_2)/(T_1 + T_2)}$ is considered constant for building heating process [43]. Here, k'_{cv} covers the approximation of the nonlinear term.
- Radiation, specified by $\dot{T}_2 = (T_1^4 - T_2^4)/k_{ra}$, is the heat transfer through the air, k_{ra} is the radiation constant.

4.4. Formulation of the model

The heat transfer from the heating pipes to ceiling surfaces as well as the transfer through the walls can be represented by the conduction. The heat transfer between the wall surfaces and the zone air corresponds to the convection and radiation, respectively. For the sake of simplicity, functions \mathcal{D} for the conduction and \mathcal{R} for the convection and radiation are defined as

$$\mathcal{D}(T, \mathcal{D}) = \sum_{T_d \in \mathcal{D}} \frac{T_d - T}{k_i}, \tag{15}$$

$$\mathcal{R}(T, \mathcal{R}) = \sum_{T_r \in \mathcal{R}} \frac{T_r - T}{k_i} + \frac{T^4 - T^4}{k_j}, \tag{16}$$

where \mathcal{D}, \mathcal{R} are the sets of all appropriate sources of heat, T is the influenced temperature and k_i, k_j are unknown time constants, indices i, j only denote that all used constants are different (even for every use of functions \mathcal{D} and \mathcal{R}).

The building's physics can be described by a set of non-linear equations utilizing the heat transfer relations as described above. The following non-linear equations are considered fully describing the Trnsys model.

Table 2
MRI and DSPM: numerical results: stage I, selection of inputs.

Iter.	1					2				
	Model	Criterion				Model	Criterion			
		T	KS	Fit [%]	R ²		T	KS	Fit [%]	R ²
DSPM	1,2,3	89.21	1.3E-13	74.42	0.937	1,2,3,8	0.00	0.98	77.18	0.959
	1,2,4	72.28	7.1E-10	70.45	0.913	1,2,4,8	48.66	1.5E-04	68.88	0.903
	1,2,5	95.41	2.6E-14	68.44	0.901	1,2,5,8	60.29	2.2E-07	69.43	0.907
	1,2,6	95.10	3.9E-14	67.79	0.897	1,2,6,8	59.14	3.9E-07	70.54	0.913
	1,2,7	95.41	2.6E-14	68.42	0.901	1,2,7,8	59.15	3.9E-07	70.51	0.913
	1,2,8	59.17	3.9E-07	70.49	0.913	1,2,8,9	60.29	2.2E-07	69.43	0.907
	1,2,9	95.41	2.6E-14	68.42	0.901	1,2,8,10	59.17	3.9E-07	70.49	0.913
	1,2,10	95.10	3.9E-14	67.73	0.897	1,2,8,11	60.29	2.2E-07	69.43	0.907
	1,2,11	95.41	2.6E-14	68.42	0.901	1,2,8,12	27.25	2.7E-03	72.01	0.924
	1,2,12	95.00	3.9E-14	68.61	0.902	-	-	-	-	-
	1,2,3	159.82	2.7E-29	70.71	0.960	1,2,3,8	0.00	0.95	80.35	0.982
	1,2,4	126.02	1.4E-18	74.93	0.940	1,2,4,8	87.51	2.5E-10	75.02	0.940
1,2,5	163.31	4.4E-30	69.20	0.915	1,2,5,8	109.14	5.8E-14	72.87	0.929	
1,2,6	163.52	4.4E-30	69.47	0.915	1,2,6,8	109.63	3.9E-14	74.49	0.940	
1,2,7	163.43	4.4E-30	69.64	0.915	1,2,7,8	106.74	2.9E-13	75.25	0.941	
1,2,8	103.61	1.4E-12	77.69	0.952	1,2,8,9	108.68	8.8E-14	73.24	0.931	
1,2,9	163.89	2.4E-30	71.02	0.921	1,2,8,10	107.11	2.9E-13	75.37	0.941	
1,2,10	163.10	4.4E-30	69.30	0.915	1,2,8,11	107.73	2.0E-13	73.63	0.931	
1,2,11	163.26	4.4E-30	71.35	0.922	1,2,8,12	76.53	6.6E-08	75.54	0.943	
1,2,12	162.26	1.5E-29	72.17	0.923	-	-	-	-	-	

Table 3
MRI and DSPM: numerical results: stage II, selection of states.

Iter.	1					2				
	Model	Criterion				Model	Criterion			
		T	KS	Fit [%]	R ²		T	KS	Fit [%]	R ²
DSPM	1,6,7,12	26.5	6.1E-04	72.8	0.940	1,2,6,7,8,12	0.0	0.98	85.8	0.980
	2,6,8,12	19.8	6.8E-04	83.2	0.973	2,3,6,8,9,12	20.2	5.5E-04	75.4	0.941
	3,6,9,12	19.8	6.7E-04	82.2	0.968	2,4,6,8,10,12	19.8	6.7E-04	75.9	0.944
	4,6,10,12	19.8	6.7E-04	76.3	0.944	2,5,6,8,11,12	19.8	6.7E-04	75.8	0.944
	5,6,11,12	19.8	6.7E-04	76.2	0.944	2,6,8,12,13,16	19.9	6.7E-04	83.3	0.973
	6,12,13,16	19.8	6.7E-04	82.9	0.972	2,6,8,12,14,17	20.2	5.5E-04	83.3	0.973
	6,12,14,17	19.9	6.7E-04	82.7	0.971	2,6,8,12,15,18	20.0	6.7E-04	83.2	0.973
MRI	6,12,15,18	19.8	6.7E-04	82.8	0.972	-	-	-	-	-
	1,6,7,12	69.0	2.1E-06	78.0	0.973	1,2,6,7,8,12	0.0	1	81.5	0.986
	2,6,8,12	50.5	2.7E-10	82.1	0.969	2,3,6,8,9,12	47.0	7.1E-10	80.0	0.961
	3,6,9,12	52.9	8.7E-11	82.8	0.971	2,4,6,8,10,12	50.2	3.6E-10	81.3	0.965
	4,6,10,12	50.7	2.5E-10	81.5	0.967	2,5,6,8,11,12	50.0	3.6E-10	81.2	0.965
	5,6,11,12	50.7	2.5E-10	81.5	0.967	2,6,8,12,13,16	52.1	1.8E-10	82.7	0.970
	6,12,13,16	53.4	8.7E-11	82.6	0.972	2,6,8,12,14,17	51.8	2.5E-10	82.5	0.970
6,12,14,17	53.2	8.7E-11	82.6	0.971	2,6,8,12,15,18	52.0	1.8E-10	82.6	0.970	
6,12,15,18	53.3	8.7E-11	82.6	0.971	-	-	-	-	-	

Table 4
PSPM: Model complexity selection procedure.

Iteration 1			Iteration 2		
Model	L	r	Model	L	r
<i>Input analysis</i>					
U 1,2,3	11 157.8	66	U 1,2,3,4	11 964.1	70
U 1,2,4	11 600.6	60	U 1,2,4,5	11 668.5	61
U 1,2,5	11 182.0	57	U 1,2,4,6	11 669.7	62
U 1,2,6	11 159.2	58	U 1,2,4,7	11 607.3	61
U 1,2,7	11 170.7	57	U 1,2,4,8	11 605.2	64
U 1,2,8	11 536.1	60	U 1,2,4,9	11 746.9	61
U 1,2,9	11 166.3	57	U 1,2,4,10	11 746.9	62
U 1,2,10	11 166.3	58	U 1,2,4,11	11 765.3	61
U 1,2,11	11 168.0	57	U 1,2,4,12	11 631.3	68
U 1,2,12	11 175.6	64	-	-	-
<i>State analysis</i>					
X 1,6,7,12	11 842.2	20	X 1,2,6,7,8,12	11 948.3	26
X 2,6,8,12	11 094.8	18	X 1,3,6,7,9,12	11 832.0	30
X 3,6,9,12	11 081.4	22	X 1,4,6,7,10,12	11 831.9	28
X 4,6,10,12	6692.6	20	X 1,5,6,7,11,12	11 831.9	28
X 5,6,11,12	6692.0	20	X 1,6,7,12,13,16	11 867.2	30
X 6,12,13,16	6698.5	22	X 1,6,7,12,14,17	11 867.3	29
X 6,12,14,17	6698.5	20	X 1,6,7,12,15,18	11 867.3	29
X 6,12,15,18	6698.5	20	-	-	-

Table 5
PSPM: evaluation of the likelihood and using LRT.

Model	L	r	p-value
<i>(a) Likelihood test results</i>			
U 1,2	11 166.7	56	0.0000
U 1,2,4	11 600.6	60	0.0000
U 1,2,3,4	11 964.1	70	1.0000
X 6,12	6 692.0	12	0.0000
X 1,6,7,12	11 842.2	20	0.0000
X 1,2,6,7,8,12	11 948.3	26	0.9993
<i>Other models</i>			
Model	L	r	
<i>(b) Model complexity selection: initial and full models</i>			
The simplest input structure	U 1,2	11 166.7	56
The simplest state structure	X 6,12	6692.0	12
The most complex model	Full	11 964.7	90

$$\begin{aligned}
 \hat{T}_{c_1} &= D(T_{c_1}, \{T_{sw_1}, T_o\}) + \mathcal{R}(T_{c_1}, \{T_{z_1}\}), \\
 \hat{T}_{wall_1} &= D(T_{wall_1}, \{T_{wall_2}\}) + \mathcal{R}(T_{wall_1}, \{T_{z_1}\}), \\
 \hat{T}_{s_1} &= D(T_{s_1}, \{T_{os_1}\}) + \mathcal{R}(T_{s_1}, \{T_{z_1}\}), \\
 \hat{T}_{w_1} &= D(T_{w_1}, \{T_{ow_1}\}) + \mathcal{R}(T_{w_1}, \{T_{z_1}\}), \\
 \hat{T}_{n_1} &= D(T_{n_1}, \{T_{on_1}\}) + \mathcal{R}(T_{n_1}, \{T_{z_1}\}), \\
 \hat{T}_{z_1} &= \mathcal{R}(T_{z_1}, \{T_{c_1}, T_{wall_1}, T_{s_1}, T_{w_1}, T_{n_1}, T_o, T_{sky}\}) + \frac{\dot{Q}_s}{k_i} + \frac{\dot{Q}_{bs}}{k_i}, \\
 \hat{T}_{c_2} &= D(T_{c_2}, \{T_{sw_2}, T_o\}) + \mathcal{R}(T_{c_2}, \{T_{z_2}\}), \\
 \hat{T}_{wall_2} &= D(T_{wall_2}, \{T_{wall_1}\}) + \mathcal{R}(T_{wall_2}, \{T_{z_2}\}), \\
 \hat{T}_{s_2} &= D(T_{s_2}, \{T_{os_2}\}) + \mathcal{R}(T_{s_2}, \{T_{z_2}\}), \\
 \hat{T}_{e_2} &= D(T_{e_2}, \{T_{oe_2}\}) + \mathcal{R}(T_{e_2}, \{T_{z_2}\}), \\
 \hat{T}_{n_2} &= D(T_{n_2}, \{T_{on_2}\}) + \mathcal{R}(T_{n_2}, \{T_{z_2}\}), \\
 \hat{T}_{z_2} &= \mathcal{R}(T_{z_2}, \{T_{c_2}, T_{wall_2}, T_{s_2}, T_{e_2}, T_{n_2}, T_o, T_{sky}\}) + \frac{\dot{Q}_s}{k_i} + \frac{\dot{Q}_{bs}}{k_i}, \quad (17) \\
 \hat{T}_{os_1} &= D(T_{os_1}, \{T_{s_1}\}) + \mathcal{R}(T_{s_1}, \{T_o, T_{sky}\}) + \frac{\dot{Q}_s}{k_i} + \frac{\dot{Q}_{bs}}{k_i}, \\
 \hat{T}_{ow_1} &= D(T_{ow_1}, \{T_{w_1}\}) + \mathcal{R}(T_{w_1}, \{T_o, T_{sky}\}) + \frac{\dot{Q}_w}{k_i} + \frac{\dot{Q}_{bw}}{k_i}, \\
 \hat{T}_{on_1} &= D(T_{on_1}, \{T_{n_1}\}) + \mathcal{R}(T_{n_1}, \{T_o, T_{sky}\}) + \frac{\dot{Q}_n}{k_i} + \frac{\dot{Q}_{bn}}{k_i}, \\
 \hat{T}_{os_2} &= D(T_{os_2}, \{T_{s_2}\}) + \mathcal{R}(T_{s_2}, \{T_o, T_{sky}\}) + \frac{\dot{Q}_s}{k_i} + \frac{\dot{Q}_{bs}}{k_i}, \\
 \hat{T}_{oe_2} &= D(T_{oe_2}, \{T_{e_2}\}) + \mathcal{R}(T_{e_2}, \{T_o, T_{sky}\}) + \frac{\dot{Q}_e}{k_i} + \frac{\dot{Q}_{be}}{k_i}, \\
 \hat{T}_{on_2} &= D(T_{on_2}, \{T_{n_2}\}) + \mathcal{R}(T_{n_2}, \{T_o, T_{sky}\}) + \frac{\dot{Q}_n}{k_i} + \frac{\dot{Q}_{bn}}{k_i}.
 \end{aligned}$$

Table 6
PSPM: Quantitative results of two stage model complexity selection procedure.

Model	Criterion			
	T	KS	Fit [%]	R ²
U 1,2	80.80	1.00E-09	64.44	0.87
U 1,2,4	5.69	6.86E-02	72.66	0.93
U 1,2,3,4	1.25	2.07E-01	78.97	0.96
X 6,12	281.89	2.00E-13	79.25	0.96
X 1,6,7,12	1.11	1.85E-01	87.05	0.98
X 1,2,6,7,8,12	0.00	4.17E-01	89.33	0.99
Full	0.00	9.00E-01	89.37	0.99

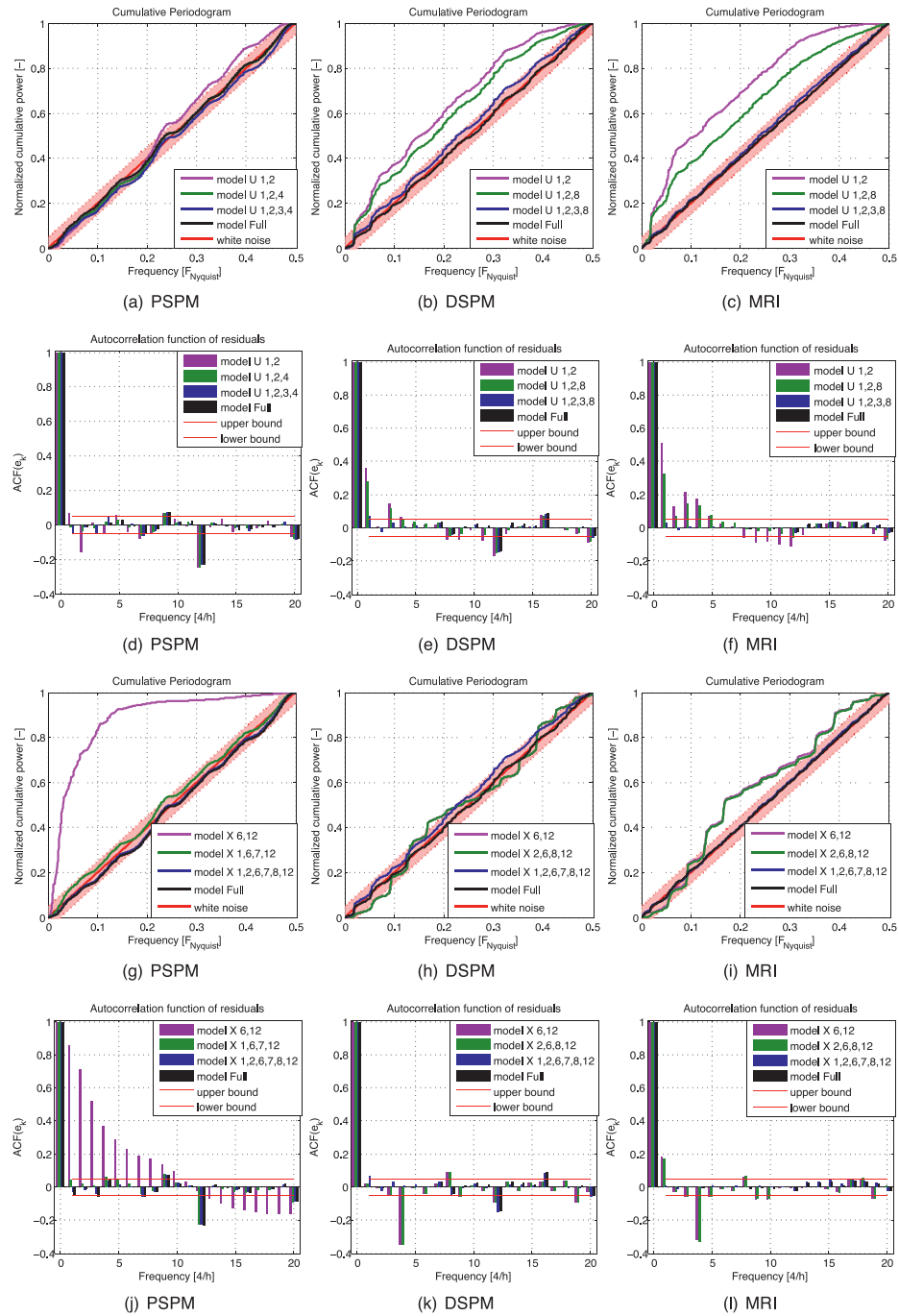

Fig. 3. Cumulative periodograms and partial autocorrelations using PSPM (first column), DSPM modeling (second column) and MRI (last column). First two rows correspond to the system inputs, while the other two to the system states. The lower and upper bounds corresponds to the 5% confidence level for all cases.

The corresponding system inputs and states are defined in Table 1. The non-linear model (Eq. (17) with Eq. (15) and Eq. (16)) can be linearized around the operating point P_0 naturally chosen as a stable state with maximum entropy $P_0 = [T, T_r]$, where $T_r = T$ for all $T_r \in \mathfrak{R}$. Then $\sum_{T_r \in \mathfrak{R}} \frac{\partial \mathcal{R}(T, \mathfrak{R})}{\partial T_r} |_{P_0} \approx \sum_{T_r \in \mathfrak{R}} (T_r - T)/K_i$, with K_i being the constant of proportionality. Under this assumption, the linear approximation of Eq. (17) can be written in the same form, but $\mathcal{R}_{lin}(T, \mathfrak{R})$,

$$\mathcal{R}_{lin}(T, \mathfrak{R}) = \sum_{T_r \in \mathfrak{R}} (T_r - T)/K_i, \quad (18)$$

must be used instead of Eq. (16). Note that the constants K_i in Eq. (18) and k_i in Eq. (16) have different meanings. Except for the full model, some simpler models are derived and the possibility of their acceptance as a good representative of the system is investigated.

4.5. Results

The full complexity linear model is identified first. This model is composed of Eq. (17) with linear function Eqs. (15) and (18) and further on is referred to as full model. When using the DSPM and the MRIs, the model of the following form is obtained

$$y(z) = G(z)u(z) + H(z)e(z), \quad (19)$$

with y , u , e being output, input and noise sequences, $G(z)$ and $H(z)$ the transfer functions corresponding to the deterministic and stochastic³ parts of the system, whilst in case of the PSPM, the state-space description as follows is at hand

$$dx_t = (A(\theta)x_t + B(\theta)u_t)dt + \sigma(\theta)d\omega_t, \quad (20)$$

$$y_t = C(\theta)x_t + D(\theta)u_t + e_t, \quad (21)$$

where ω_t is the n -dimensional Wiener process and $e_t \sim \mathcal{N}(0, S(\theta))$ is the white noise process, $t \in \mathbb{R}$ is the time, $x_t \in \mathbb{R}^n$ is the state vector, $u_t \in \mathbb{R}^m$ is the input vector, $y_t \in \mathbb{R}^l$ is the output vector, $\theta \in \Theta \subset \mathbb{R}^p$ is the vector of parameters, $A(\bullet)$, $B(\bullet)$, $\sigma(\bullet)$, $C(\bullet)$, $D(\bullet)$ and $S(\bullet)$ are the nonlinear functions of parameters. Then, the model selection is performed in two stages as described in Section 3.

The results for the MRIs and the DSPM are summarized in Table 2 for the selection of inputs and Table 3 for the selection of states. The models as used in these tables are defined by indices of the corresponding inputs and states, see Table 1. The most appropriate model (min value T or max value of KS) and its characteristics selected in the corresponding iteration (and each method) is highlighted. It is worthy to remark that both tests have selected the same model for both modeling approaches, which is qualitatively identical with the full model. Moreover, its quantitative statistics are impressive as well, the coefficient of determination close to one (0.98) and the multi-step ahead prediction (15 steps) recorded 85.8% and 81.5% fit factors, respectively (one-step ahead prediction is almost perfect).

The results for models obtained by the PSPM recorded in Tabs. 4–6 show that both the first and the second stages had two iterations and thereafter the procedure stopped as the increase in the model quality compared to the full model was statistically insignificant. The highlighted models had the highest value of the likelihood, therefore were selected and tested by LRT against the full model. The model selected as the most appropriate representative of the full model contains only 4 inputs (out of 12, namely both supply water temperatures, ambient temperature and total solar radiation on south surface) and only 6 states (out of 18). The performance of the model described by the fit factor and the coefficient of

determination were computed for 15 step-ahead predictions. The quantitative as well as qualitative results of the model selected as a satisfactory representative of the full model have indeed recorded satisfactory results and is almost indistinguishable from the full model as far as value of the likelihood function, properties of the residuals and prediction properties are considered.

The residuals for models obtained by all three methods are depicted in Fig. 3. The first column is devoted to PSPM, the second to DSPM and the last one to MRI. The cumulative periodograms and partial autocorrelations in the first two rows correspond to the system inputs, while the other two to the system states. The red line represents the cumulative periodograms for white noise and dotted red lines correspond to $\pm 5\%$ significance level from the white noise line. As was already stated, in each iteration an input (a pair of states) is added, which corresponds to the periodograms of respective model residuals. It can be seen that addition of the inputs (states) causes the approach⁴ of the periodogram curves towards the tolerance range for white noise. The selected model (depicted in blue) is well within the tolerance range, i.e. its residuals are white noise sequences, which are further tested as described in Section 4.5. The red horizontal lines in subfigures depicting autocorrelation functions correspond to 5% tolerance range. Observe that the values for different frequency bins decrease with the more complex models and for the model selected as a final candidate (depicted in blue) replacing the full model are within the tolerance range for the white noise sequence.

5. Conclusions and future works

The paper proposed a new two stage procedure for model complexity selection. In the first stage, the minimum set of disturbance inputs was found. Given a minimum set of inputs, the minimum set of system states maximizing the model quality was then selected. The evaluation of the qualitative improvements of the model thanks to adding inputs/states was performed using several criteria, namely the tests of whiteness, KS test, T-criterion, fit factor and coefficient of determination. The procedure stops when there is no statistically significant quality improvement.

All three identification methods – DSPM, MRIs and PSPM consistently selected the models (zone temperatures, ceiling core temperatures and core temperatures of the common wall as for the system inputs and supply water temperatures, ambient temperature, solar radiation on the south surface as for the states). The ultimately selected model containing only 4 inputs and 6 states had similar properties to the model with the full set of inputs and states. This can lead to both technical and economic savings as less states and disturbance inputs mean less sensors. Moreover, in case of the disturbances provided as a service (e.g. weather forecasts for building climate control), the lower number of disturbances result into financial savings. Additionally, using the proposed procedure, the consequent optimal control problem is computationally less demanding even for large systems such as buildings.

Next research is going to focus on application of the proposed technique on a real building. Moreover, it will be implemented within the predictive control framework already working on the building of the CTU in Prague. In addition, the future research should include the numerical evaluation of the savings separately, due to the proposed model selection procedure and due to predictive control itself.

³ Note that $H(z)$ includes non-linearities of the detailed Trnsys model which cannot be described by the linearized full complex model.

⁴ Note that for DSPM and MRI, the selection criteria were based on periodogram. Therefore, in each iteration an improvement of the corresponding periodogram is notable. In case of PSPM, this is not the case, as it has a different selection criterion and the periodogram is shown only for validation purposes.

Acknowledgments

The project has been supported by the grant of the Grant Agency of Czech Republic (GACR) no. P103/12/1187.

References

- [1] L. Pérez-Lombard, J. Ortiz, C. Pout, A review on buildings energy consumption information, *Energy and Buildings* 40 (3) (2008) 394–398, <http://dx.doi.org/10.1016/j.enbuild.2007.03.007>.
- [2] J. Šíroký, F. Oldewurtel, J. Cigler, S. Prívvara, Experimental analysis of model predictive control for an energy efficient building heating system, *Applied Energy* 88 (9) (2011) 3079–3087, <http://dx.doi.org/10.1016/j.apenergy.2011.03.009>.
- [3] F. Oldewurtel, A. Parisio, C. Jones, M. Morari, D. Gyalistras, M. Gwerder, V. Stauch, B. Lehmann, K. Wirth, Energy efficient building climate control using stochastic model predictive control and weather predictions, in: 2010 American Control Conference (ACC), 2010, pp. 5100–5105.
- [4] P.D. Moročan, R. Bourdais, D. Dumur, J. Buisson, Building temperature regulation using a distributed model predictive control, *Energy and Buildings* 42 (9) (2010) 1445–1452, <http://dx.doi.org/10.1016/j.enbuild.2010.03.014>.
- [5] C. Verhelst, F. Logist, J.V. Impe, L. Helsen, Study of the optimal control problem formulation for modulating air-to-water heat pumps connected to a residential floor heating system, *Energy and Buildings* 45 (0) (2012) 43–53, <http://dx.doi.org/10.1016/j.enbuild.2011.10.015>.
- [6] L. Ferkl, J. Šíroký, Ceiling radiant cooling: comparison of armax and subspace identification modelling methods, *Building and Environment* 45 (1) (2010) 205–212, <http://dx.doi.org/10.1016/j.buildenv.2009.06.004>.
- [7] J. Cigler, S. Prívvara, Z. Váňa, E. Žáčková, L. Ferkl, Optimization of predicted mean vote index within model predictive control framework: Computationally tractable solution, *Energy and Buildings*, doi:<http://dx.doi.org/10.1016/j.enbuild.2012.05.022>.
- [8] Y. Ma, F. Borrelli, B. Hency, B. Coffey, S. Bengea, P. Haves, Model predictive control for the operation of building cooling systems, in: 2010 American Control Conference (ACC), 2010, pp. 5106–5111.
- [9] S. Prívvara, J. Šíroký, L. Ferkl, J. Cigler, Model predictive control of a building heating system: the first experience, *Energy and Buildings* 43 (2–3) (2011) 564–572, <http://dx.doi.org/10.1016/j.enbuild.2010.10.022>.
- [10] D. Gyalistras, M. Gwerder, (Eds.), Use of Weather and Occupancy Forecasts for Optimal Building Climate Control (opticontrol): Two Years Progress Report, Tech. rep., ETH Zurich, Switzerland and Siemens Building Technologies Division, Siemens Switzerland Ltd., Zug, Switzerland, 2009, (chapter 8).
- [11] E. Žáčková, S. Prívvara, Z. Váňa, Model predictive control relevant identification using partial least squares for building modeling, in: 2010 IEEE Australian Control Conference (AUCC), 2011, pp. 422–427.
- [12] M. Sourbron, C. Verhelst, L. Helsen, Building models for model predictive control of office buildings with concrete core activation, *Journal of Building Performance Simulation*, (2012) 1–24, doi:10.1080/19401493.2012.680497.
- [13] Z. Váňa, H. Preisig, System identification in frequency domain using wavelets: Conceptual remarks, *System and Control Letters*, in press, doi:10.1016/j.sysconle.2012.07.004.
- [14] P. Bacher, H. Madsen, Identifying suitable models for the heat dynamics of buildings, *Energy and Buildings* 43 (7) (2011) 1511–1522, <http://dx.doi.org/10.1016/j.enbuild.2011.02.005>.
- [15] K. Andersen, H. Madsen, L. Hansen, Modelling the heat dynamics of a building using stochastic differential equations, *Energy and Buildings* 31 (1) (2000) 13–24.
- [16] M. Jiménez, H. Madsen, K. Andersen, Identification of the main thermal characteristics of building components using Matlab, *Building and Environment* 43 (2) (2008) 170–180, <http://dx.doi.org/10.1016/j.buildenv.2006.10.030>.
- [17] S. Wang, X. Xu, Simplified building model for transient thermal performance estimation using GA-based parameter identification, *International Journal of Thermal Sciences* 45 (4) (2006) 419–432.
- [18] G. Levermore, *Building Energy Management Systems: An Application to Heating and Control*, E&FN Spon, 1992.
- [19] S. Prívvara, Z. Váňa, D. Gyalistras, J. Cigler, C. Sagerschnig, M. Morari, L. Ferkl, Modeling and identification of a large multi-zone office building, in: 2011 IEEE International Conference on Control Applications (CCA), 2011, pp. 55–60, <http://dx.doi.org/10.1109/CCA.2011.6044402>.
- [20] T. Bohlin, S. Graebe, Issues in nonlinear stochastic grey box identification, *International Journal of Adaptive Control and Signal Processing* 9 (6) (2007) 465–490.
- [21] N.R. Kristensen, H. Madsen, S.B. Jorgensen, Parameter estimation in stochastic grey-box models, *Automatica* 40 (2) (2004) 225–237, <http://dx.doi.org/10.1016/j.automatica.2003.10.001>.
- [22] S. Prívvara, J. Cigler, Z. Váňa, L. Ferkl, M. Šebek, Subspace identification of poorly excited industrial systems, in: 49th IEEE Conference on Decision and Control (CDC), 2010, pp. 4405–4410.
- [23] P. Van Overschee, B. De Moor, *Subspace Identification for Linear Systems*, Kluwer Academic Publishers, Kluwer Academic Publishers, 101 Philip Drive, Assinippi Park, Nowell, Massachusetts, 1999.
- [24] M. Verhaegen, P. Dewilde, Subspace model identification part 1. The output-error state-space model identification class of algorithms, *International Journal of Control* 56 (5) (1992) 1187–1210.
- [25] S. Prívvara, J. Cigler, Z. Váňa, L. Ferkl, Incorporation of system steady state properties into subspace identification algorithm, *International Journal of Modelling, Identification and Control* 16 (2) (2012).
- [26] P. Trnka, V. Havlena, Subspace like identification incorporating prior information, *Automatica* 45 (4) (2009) 1086–1091, <http://dx.doi.org/10.1016/j.automatica.2008.12.005>.
- [27] A. Alenany, H. Shang, M. Soliman, I. Ziedan, Brief paper-improved subspace identification with prior information using constrained least squares, *Control Theory & Applications, IET* 5 (13) (2011) 1568–1576.
- [28] T. Louis, Finding the observed information matrix when using the em algorithm, *Journal of the Royal Statistical Society. Series B (Methodological)* (1982) 226–233.
- [29] G. McLachlan, T. Krishnan, *The EM Algorithm and Extensions*, vol. 382, John Wiley and Sons, 2008.
- [30] L. Ljung, *Prediction Error Estimation Methods*, vol. 21, Birkhäuser Boston, 2002, <http://dx.doi.org/10.1007/BF01211648>, pp. 11–21.
- [31] D. Shook, C. Mohtadi, S. Shah, Identification for long-range predictive control, *Control Theory and Applications, IEE Proceedings D* 138 (1) (1991) 75–84.
- [32] D. Shook, C. Mohtadi, S. Shah, A control-relevant identification strategy for GPC, *IEEE Transactions on Automatic Control* 37 (7) (2002) 975–980.
- [33] R. Gopaluni, R. Patwardhan, S. Shah, MPC relevant identification – tuning the noise model, *Journal of Process Control* 14 (6) (2004) 699–714, <http://dx.doi.org/10.1016/j.procont.2003.05.001>.
- [34] R. Gopaluni, R. Patwardhan, S. Shah, Bias distribution in MPC relevant identification, in: *Proceedings of IFAC world congress, Barcelona, Citeaser*, 2002, pp. 2196–2201.
- [35] L. Ljung, *System Identification*, Wiley Online Library, 1999.
- [36] G. Box, G. Jenkins, G. Reinsel, *Time Series Analysis*, Holden-day San Francisco, 1970.
- [37] I. Young, Proof without prejudice: use of the Kolmogorov-Smirnov test for the analysis of histograms from flow systems and other sources, *Journal of Histochemistry & Cytochemistry* 25 (7) (1977) 935.
- [38] G. Fasano, A. Franceschini, A multidimensional version of the Kolmogorov-Smirnov test, *Monthly Notices of the Royal Astronomical Society* 225 (1987) 155–170.
- [39] T. Pukkila, P. Krishnaiah, On the use of autoregressive order determination criteria in multivariate white noise tests, *IEEE Transactions on Acoustics, Speech and Signal Processing* 36 (9) (1988) 1396–1403, <http://dx.doi.org/10.1109/29.90367>.
- [40] P. Matisko, V. Havlena, Optimality tests and adaptive Kalman filter, in: Preprint submitted to 16th IFAC Symposium on System Identification, IFAC, 2012, in press, doi:10.3182/20120711-3-BE-2027.00011.
- [41] B. Lehmann, V. Dorer, M. Koschenz, Application range of thermally activated building systems tabs, *Energy and Buildings* 39 (5) (2007) 593–598.
- [42] G. Goodwin, R. Payne, *Dynamic System Identification: Experiment Design and Data Analysis*, vol. 136, Academic Press, 1977.
- [43] M. Barták, Úvod do přenosových jevu pro inteligentní budovy, Czech Republic, CTU Prague, Prague, 2010.

RESULTS

The application of modern control approaches such as [MPC](#) to control of [BAS](#) is a very complex task of i) designing the experiment for obtaining the quality data from the building ¹, ii) processing the data gathered usually in a raw form in a database, iii) proposing the model structure suitable for a given type of the building, iv) choosing the best available identification method and obtaining the model of the building, v) selecting the suitable control criterion and computation of the optimal control law, vi) implementing the control action to the available hardware solution, and vii) testing and adjusting any of the previous steps.

This thesis is aimed at providing a reader with a complex view on the process of building modeling and identification. First, the approaches suitable for creating models intended for predictive control were analysed and some recommendations were given. It was found out, that grey-box modeling (whatever approach out of many is chosen) is very common and useful in modeling of low complex buildings with a few inputs/states. This should be a preferable way of modeling for low complex buildings as it retains the physical properties and structure of the modelled system.

On the other hand, when a large building with tens or even hundreds inputs/states is considered, the grey-box modeling is not a viable option any more and statistically-based approaches such as [4SID](#) become a very useful tool. These methods, however, require the data of certain quality which is often problematic in the real life. Therefore, two different approaches were suggested to treat the problem, namely i) incorporation of [PI](#) about the system to be modelled, and ii) a combined approach using the computer aided simulation tools and statistical identification. The former uses some knowledge of the system such as the static gain or non-existence of the system matrix D and by including them into the [4SID](#) algorithm, the results are more accurate. This solution is, however, not valid universally, as the user does not always have the proper kind of prior information, or this information does not help to the desired extent.

The other approach is based on the idea, that the building can be mimic quite precisely by building modeling tools, such as [Trnsys](#), [EnergyPlus \(EP\)](#), etc. providing thus the user with an implicit

¹ This step is very often replaced or supported by the data generated by some software tool.

model (not suitable for predictive control though). Statistical methods such as $\mathcal{4}SID$ on the other hand are able to provide an explicit model suitable for predictive control, however, needs the sufficiently excited data. A new approach that unifies both frameworks was introduced in this thesis. First, the building is modelled by the Software (SW) tools, then the sufficiently excited data are generated for $\mathcal{4}SID$ resulting thus to the Linear Time Invariant (LTI) model suitable for predictive control.

Finally, the very natural question arises, when considering what inputs/states should be included in the model of a building. It is a very frequent case, that there is an enormous number of measured disturbances, however, most of them does not have a significant effect on the system. A new approach of systematic selecting the system disturbance inputs and states was proposed in the thesis, when their contributions are ordered according to their effect and they are iteratively added to the model and tested, whether their inclusion to the model is statically significant. The resulting model is of much lower order than the "full" model but has almost the same quality. Moreover, the residuals of the model are tested against the hypothesis of white noise.

CONCLUSIONS AND POTENTIAL DEVELOPMENT

This work provided a thorough study of the building modeling approaches and techniques. These were discussed both in theoretical level and case studies. The main theoretical legacy of the thesis is multiple. Firstly, we have discussed variety of approaches to the incorporation of the prior information into the subspace algorithm enabling thus merge of black-box nature of the subspace algorithm and some knowledge of physical properties of the system. A new algorithm of incorporating the steady state gain information and presence of no feed-through was proposed. Secondly, a new methodology exploiting the best out of computer aided tools and statistically-based identification was presented. The physical model of a building using the software is created and verified, data for identification are generated fulfilling thus requirements for proper statistical properties, and successively modified subspace algorithm is performed. This approach enables identification of the buildings of arbitrary complexity and level of details. Thirdly, the utilization of the multi-step ahead prediction framework was analyzed and a combined algorithm using [PLS](#) was proposed. Finally, the model selection and validation methodology was proposed.

The proposed algorithms and techniques have been demonstrated on several case studies.

- A simple example of [CTU](#) building using a grey-box modeling (with a predictive control that recorded over 20% savings over the two-year period).
- A new methodology based on interconnection of the building simulation software and traditional identification methods in order to avoid the statistical problems with data gathered from the real building in Munich. The building was modeled using [EP](#), which was excited by specially proposed signals to get data of a good quality. Then the subspace identification approach (with some modifications) was applied to acquire a model suitable for predictive control. To the author's best knowledge, there was no detailed building modeling intended for predictive control of such a size.
- The algorithm of incorporation of the [PI](#) into the subspace identification methods. The incorporation is performed directly into the system matrices B and D , thus enables a certain type of a prior information, e.g. static gain. The incorporated [PI](#) is able to significantly improve the identification results and substitute

the lack of information in the input-output data. Moreover, it notably improves a model for the control purposes by approaching to the physical system structure. However, the quality of the identification is sensitive to the accuracy of a prior estimate of parameters. The constructed model has been used for the temperature control in a real operation of the building of the CTU.

- Many of the theoretical results were demonstrated on a model created in Trnsys environment. The model mimic a typical two-zone building where many of the proposed algorithms were tested on this benchmark example.

5.1 FUTURE DEVELOPMENT

Even though there was a huge development in building modeling, identification and control recently, the fundamental questions still remain. Most of the control solutions are computed “on-line”, iteratively, with a significant need of computational resources. The industrial practice, however, needs a light-weight (both memory and computational power) solution that would be possible to implement on the current hardware equipment. A promising directions seems to be an *explicit* predictive control, when the control law is pre-computed offline. The unsolved issues in this area include the numerical problems, suitability of approximations, and especially the time-varying parameters of the system which completely ruin a current paradigm of the explicit control.

As far as the identification and modeling part is concerned, one of the greatest challenges will be the full automation of the identification procedure. Even though the predictive controllers applied to a building have proven to have an immense savings potential, the whole commissioning greatly suffers from the time necessary to complete the identification and modeling part. The experienced modeller is still needed to decide the most suitable method, algorithm settings and many others for each single building. The ultimate objective is an automated ¹ procedure functioning applied to all (or at least at a sufficiently large set) buildings with a reasonable time of commissioning.

Yet another challenging problem is the data. So far, the current paradigm was to collect the data generated by the real system or by software solution (Trnsys, EP and similar), to process them (selection of proper signal, treatment of the erroneous signals, etc.) and to launch the process of identification resulting to the model. This ap-

¹ To be honest, the full automation in sense of the currently implemented industrial controllers, will probably be always impossible, however, the effort directs towards identification process with defined at least time upper bound and exact succession of the steps, of which many could be performed automatically.

proach is quite useful for the buildings which have been operating for some time, however, is completely useless for newly built buildings or buildings being completely retrofitted thus changing their thermal properties. As the European Directive 2002/91/EC (The Directive on the Energy Performance of Buildings (DEPB)) requires all the newly built and significantly retrofitted buildings to have computed *the integrated energy performance of buildings* and introduces *minimum standards on the energy performance of new buildings and existing buildings that are subject to major renovation*, etc. As a result, this category of the buildings has a very detailed documentation available. This provides us a unique opportunity to detour above-mentioned problem of the data availability. The physical modeling (DSPM, PSPM) with the data availability from the building documentation could be very attractive approach. Very similar approach, using basic construction data was lately mentioned by a colleague of mine, David Sturzenegger of ETH Zurich.

A completely different story is a predictive control with non-linear models. Even though there is a large number of approaches that are able to provide non-linear building models, most of them are absolutely useless as multi-step ahead predictors and are very cumbersome to use in a predictive control framework. On the other hand, there are many non-linear effects in the building modeling that are currently somehow approximated. It would certainly be interesting to know in a quantitative way, what are the effects of the model approximations of the control performance.

FULLFILMENT OF THE OBJECTIVES

Here a short note on fulfilment of the aims from [Chapter 1](#) is provided.

1. *To perform a survey of the currently available approaches.* This objective was completed and described in [\[Prívvara et al., 2011, 2013a\]](#).
2. *To select and analyse the suitable approaches.* This objective was satisfied by analysis and selection of the suitable approaches described mainly in [\[Prívvara et al., 2013a\]](#).
3. *To find a solution to the specific problems of building modeling techniques.* The objective was mainly met by incorporation of [PI](#) into the [SID](#) algorithm described in [\[Prívvara et al., 2012\]](#) and by a problem of insufficient excitation and so-called co-simulation from [\[Prívvara et al., 2013a\]](#).
4. *To develop the model selection and validation methodology.* Finally, the last objective was accomplished by proposing the selection and validation methodology as described in [\[Prívvara et al., 2012\]](#).

Additionally, an interconnection of the [MRI](#) and [PLS](#) resulting from the topic of diploma thesis of that time master student Eva Žáčková are provided in [\[Prívvara et al., 2013b\]](#).

BIBLIOGRAPHY

- Bai, E., Sastry, S., 1986. Parameter identification using prior information. *International Journal of Control* 44 (2), 455–473.
- Bull, R., Chang, N., Fleming, P., 2012. The use of building energy certificates to reduce energy consumption in european public buildings. *Energy and Buildings* 50 (0), 103 – 110.
- Dickey, D., Fuller, W., 1981. Likelihood ratio statistics for autoregressive time series with a unit root. *Econometrica: Journal of the Econometric Society*, 1057–1072.
- Ekins, P., Lees, E., 2008. The impact of eu policies on energy use in and the evolution of the uk built environment. *Energy Policy* 36 (12), 4580–4583.
- ESP, 2011. Esp-r. [Http://www.esru.strath.ac.uk/Programs/ESP-r.htm](http://www.esru.strath.ac.uk/Programs/ESP-r.htm).
- ETH, 2007. Opticontrol project.
URL <http://www.opticontrol.ethz.ch/>
- Gevers, M., Euler, B., Lemaitre, A., 2005. Identification for control: Achievements and open problems. *Dynamics and Control of Process Systems* 2004, 401.
- Goethals, I., Van Gestel, T., Suykens, J., Van Dooren, P., De Moor, B., 2003. Identifying positive real models in subspace identification by using regularization. In: *Proceedings of the 13th System Identification Symposium*, Rotterdam, The Netherlands. Citeseer, pp. 1411–1416.
- Gopaluni, R., Patwardhan, R., Shah, S., 2004. MPC relevant identification–tuning the noise model. *Journal of Process Control* 14 (6), 699–714.
- Gourieroux, C., Holly, A., Monfort, A., 1982. Likelihood ratio test, wald test, and kuhn-tucker test in linear models with inequality constraints on the regression parameters. *Econometrica: Journal of the Econometric Society*, 63–80.
- Gyalistras, D., Gwerder, M., 2010. Use of weather and occupancy forecasts for optimal building climate control (opticontrol): Two years progress report. Tech. rep., Terrestrial Systems Ecology ETH Zurich, Switzerland and Building Technologies Division, Siemens Switzerland Ltd., Zug, Switzerland.

- Gyalistras, D., Gwerder, M., Oldewurtel, F., Jones, C., Morari, M., Lehmann, B., Wirth, K., Stauch, V., 2010. Analysis of energy savings potentials for integrated room automation. In: 10th REHVA World Congress Clima.
- Hazyuk, I., Ghiaus, C., 2010. A method of heating systems sizing for discontinuously occupied buildings. In: Proceedings of 10th Rehva World Congress, Clima 2010.
- Hjalmarsson, H., 2009. System identification of complex and structured systems. *European journal of control* 15 (3-4), 275–310.
- Huang, B., Kadali, R., 2008. Data-driven Subspace Approach to Predictive Control. *Dynamic Modeling, Predictive Control and Performance Monitoring*, 121–141.
- Katipamula, S., Armstrong, P. R., Wang, W., Fernandez, N., Cho, H., 2010. Efficient low-lift cooling with radiant distribution, thermal storage and variable-speed chiller controls. In: Proceedings of 10th Rehva World Congress, Clima 2010.
- Lacy, S., Bernstein, D., 2003. Subspace identification with guaranteed stability using constrained optimization. *IEEE Transactions on automatic control* 48 (7), 1259–1263.
- Ljung, L., 1999. *System Identification: Theory for user*. Prentice-Hall, Inc., Upper Saddle River, New Jersey, USA.
- Lodi, C., Bacher, P., Cipriano, J., Madsen, H., 2012. Modelling the heat dynamics of a monitored test reference environment for building integrated photovoltaic systems using stochastic differential equations. *Energy and Buildings* 50 (0), 273 – 281.
- Ma, Y., Borrelli, F., Hancey, B., Coffey, B., Bengesa, S., Haves, P., jun. 2010. Model predictive control for the operation of building cooling systems. In: *American Control Conference (ACC)*, 2010. pp. 5106–5111.
- Ma, Y., Borrelli, F., Hancey, B., Packard, A., Bortoff, S., Dec. 2009. Model Predictive Control of thermal energy storage in building cooling systems. *Proceedings of the 48h IEEE Conference on Decision and Control (CDC) held jointly with 2009 28th Chinese Control Conference*, 392–397.
- Metz, B., 2007. *Climate change 2007: mitigation of climate change: contribution of Working Group III to the Fourth Assessment Report of the Intergovernmental Panel on Climate Change*. Cambridge University Press.
- of Energy, U. D., 2011. *EnergyPlus Energy Simulation Software*. [Http://apps1.eere.energy.gov/buildings/energyplus/](http://apps1.eere.energy.gov/buildings/energyplus/).

- Oldewurtel, F., Parisio, A., Jones, C., Morari, M., Gyalistras, D., Gw-
erder, M., Stauch, V., Lehmann, B., Wirth, K., 2010a. Energy efficient
building climate control using Stochastic Model Predictive Control
and weather predictions. In: 2010 American Control Conference
(ACC2010). Baltimore, Maryland, USA.
- Oldewurtel, F., Ulbig, A., Parisio, A., Andersson, G., Morari, M.,
2010b. Reducing Peak Electricity Demand in Building Climate Con-
trol using Real-Time Pricing and Model Predictive Control. In: Con-
ference on Decision and Control, CDC.
- Perez-Lombard, L., Ortiz, J., Pout, C., 2008. A review on buildings
energy consumption information. *Energy and buildings* 40 (3), 394–
398.
- Rijksen, D. O., Wisse, C. J., Schijndel, A. W. M. V., 2009. Reducing
peak requirements for cooling by using thermally activated build-
ing systems. *Energy and Buildings*.
- Rojas, C., Barenthin, M., Welsh, J., Hjalmarsson, H., 2008. The cost of
complexity in identification of FIR systems. In: 16th IFAC World
Congress. Seoul, South Korea.
- Rossiter, J., Kouvaritakis, B., 2001. Modelling and implicit modelling
for predictive control. *International Journal of Control* 74 (11), 1085–
1095.
- Shook, D., Mohtadi, C., Shah, S., 2002. A control-relevant identifi-
cation strategy for GPC. *IEEE Transactions on Automatic Control*
37 (7), 975–980.
- Stenman, A., 2002. Model-free predictive control. In: Proceedings of
the 38th IEEE Conference on Decision and Control. Vol. 4. IEEE, pp.
3712–3717.
- Thermal Energy System Specialists, L., 2012. Transient system simu-
lation tool. [Http://www.trnsys.com](http://www.trnsys.com).
- Trnka, P., Havlena, V., Apr. 2009. Subspace like identification incorpo-
rating prior information. *Automatica* 45 (4), 1086–1091.
- Van Gestel, T., Suykens, J., Van Dooren, P., De Moor, B., 2000. Ident-
fication of Positive Real Models in Subspace Identification with
Regularization.
- Willems, J., Rapisarda, P., Markovsky, I., De Moor, B., 2005. A note
on persistency of excitation. *Systems & Control Letters* 54 (4), 325 –
329.
- Zhu, Y., 2001. *Multivariable system identification for process control*.
Elsevier.