

Czech Technical University in Prague
Faculty of Electrical Engineering



Bachelor thesis

Automation of a small flower farm

Jan Stehlík

Project supervisor: Ing. Richard Šusta, Ph.D

Study program: Electronics and Computer Science & Engineering

Branch of study: Cybernetics and Measurement

May 2008

Acknowledgments

First of all I would like to thank my family, my parents, and especially my girlfriend Hanka. All of them always pushed me forward and were a great support for me. Also I would like to thank my project supervisor Ing. Richard Šusta, Ph.D for his kind leadership and the opportunity to choose the theme of my work. Finally, I would like to express my gratitude to Ing. Vít Záhlava, CSc. and Ing. Pavel Němeček for their helpful advice on practical realization of the printed circuit board.

Prohlášení

Prohlašuji, že jsem svou bakalářskou práci vypracoval samostatně a použil jsem pouze podklady uvedené v příloženém seznamu. Nemám závažný důvod proti užití tohoto díla ve smyslu §60 Zákona č. 121/2000 Sb., o právu autorském, o právech souvisejících s právem autorským a o změně některých zákonů (autorský zákon). Obvodová schémata, a data pro výrobu jsou vydána pod licencí GPL.

V Praze dne 1.7. 2008

.....

Abstract

The aim of this project is to design a control and measuring unit of a small flower farm. This unit should be modular and easily reprogrammable for using in various applications similar to a flower farm, such as paludariums, terrariums or incubators. The design of the printed circuit board should be made with respect to low-precision manufacturing techniques used by do-it-yourself manufacturers. The source codes and electrical schemes are going to be distributed under GPL license, which means that they can be modified and redistributed without any warranty and the author doesn't have any liability. The meaning of this project is to offer an alternative to expensive commercial systems and therefore, it is written in English to be possibly spread among the world and find its users in small biological research facilities or households. Furthermore this thesis compares different environmental sensors that could be used as measuring peripherals in practical realization of the controlled system and introduces the reader to construction of a growbox or a paludarium.

Abstrakt

Cílem této práce je navrhnout řídicí a měřicí jednotku pro malopěstírnu pokojových rostlin. Tato jednotka by měla být modulární a jednoduše přeprogramovatelná, aby mohla sloužit k řízení podobných systémů jako jsou klimoboxy, terária nebo inkubátory. Návrh desky plošných spojů by měl být proveden s přihlédnutím k možnostem domácí výroby. Zdrojové kódy, schémata a výrobní data budou distribuována pod licencí GPL, což znamená, že mohou být dále distribuována a upravována, avšak autor za ně nenes žádnou právní odpovědnost. Smyslem této práce je nabídnout jednoduchou a uživatelsky přívětivou alternativu k drahým komerčním systémům a proto je psána v angličtině aby měla šanci se případně rozšířit do světa a najít si své uživatele ať už v menších biologických výzkumných zařízeních, či v domácnostech. Dále tato práce srovnává různé senzory environmentálních veličin u uvádí čtenáře do problematiky konstrukce growboxu nebo paludária.

Contents

| | | |
|----------|---|-----------|
| 1 | Introduction | 1 |
| 1.1 | The importance of indoor growing | 1 |
| 1.2 | System description and requirements | 2 |
| 1.2.1 | Lighting | 3 |
| 1.2.2 | Temperature | 5 |
| 1.2.3 | Humidity | 7 |
| 1.2.4 | Watering and fertilization | 7 |
| 1.2.5 | Ventilation | 8 |
| 2 | Analysis and hardware design | 10 |
| 2.1 | Measuring devices and peripherals | 10 |
| 2.1.1 | Temperature sensors | 10 |
| 2.1.2 | Humidity sensors | 11 |
| 2.1.3 | Alarm triggering devices | 12 |
| 2.1.3.1 | Lighting system failure detector | 12 |
| 2.1.3.2 | Water leak sensor | 13 |
| 2.1.3.3 | Trespassing sensor | 13 |
| 2.2 | Microprocessor ATmega32 | 14 |
| 2.3 | Circuitry design | 15 |
| 3 | Software design and user interface | 18 |
| 3.1 | UART communication | 18 |
| 3.2 | The Flower Farm application | 18 |
| 4 | Implementation of the hardware design | 20 |
| 5 | The control unit testing | 22 |
| 5.1 | Electrical and mechanical testing | 22 |
| 5.2 | User interface testing | 22 |
| 6 | Conclusion | 23 |
| 7 | Bibliography | 24 |

List of Figures

| | | |
|-----|---|----|
| 1.1 | Two examples of a paludarium | 1 |
| 1.2 | Hydroponic and aeroponic growing systems | 2 |
| 1.3 | Construction of a mobile growbox | 3 |
| 1.4 | Spectrum of a high pressure sodium vapor lamp | 4 |
| 1.5 | Comparing spectrums of the most common fluorescent lamps | 5 |
| 1.6 | Graph of the chlorophyll sensitivity to various light spectrums | 6 |
| 1.7 | The UFO radial ventilator | 9 |
| | | |
| 2.1 | Temperature sensors overview | 11 |
| 2.2 | Humidity sensors overview | 12 |
| 2.3 | Scheme of the alarm triggering circuitry | 13 |
| 2.4 | VT43N1 photoresistor | 13 |
| 2.5 | Water leak sensor | 14 |
| 2.6 | Trespassing door sensor | 14 |
| 2.7 | ATmega32 microprocessor pinout | 15 |
| 2.8 | Circuitry scheme of power supply | 16 |
| 2.9 | Complete circuitry scheme of the control unit | 16 |
| | | |
| 3.1 | Scheme of the RS232 interface pinout | 19 |
| | | |
| 4.1 | A picture of the completed control unit | 20 |
| 4.2 | Printed Circuit Board of the control unit | 21 |
| 4.3 | Route layer of the control unit | 21 |

List of Tables

| | | |
|-----|--|---|
| 1.1 | The optimal concentration of chemicals in water tank | 9 |
|-----|--|---|

1 Introduction

The word vivarium comes from Latin and means literally "place of life". It is an enclosed area for keeping and raising animals or plants for observation and research. Often, a part of the ecosystem is simulated on a smaller scale with controls for environmental conditions. A vivarium may be small enough to sit on a desk such as a terrarium or an aquarium, or may be a very large structure. Two examples of a controlled environmental system called paludarium can be seen on figure 1.1. They serve predominantly for aesthetic purposes and they are supposed to accurately simulate the warm, humid habitat of a tropical biotop. In this project I will concentrate on use of the designed environmental system as a small flower farm called growbox. However, it is important that the control unit could serve in a terrarium or an incubator as well with very few changes made.



Figure 1.1: Two examples of a paludarium

1.1 The importance of indoor growing

Indoor growing has become increasingly common over the past decade due to increased availability of equipment and instructions on how to cultivate. Lots of plants grown indoors in growboxes such as plants from the family Orchidaceae are very sensitive to atmospheric conditions and therefore, the control system has to be accurate and reliable to maintain stable conditions that simulate the plant's natural habitat. As a reward we may expect excessive outcomes and we have the ability to research thoroughly the influence of controlled environmental conditions on the plant's growth. This opportunity to control and measure every single aspect of the growth in conjunction with modern planting techniques such as micropropagation and hydroponics makes it possible to grow



Figure 1.2: Hydroponic and aeroponic growing systems

stronger and better plants more efficiently. Indoor growing is likely to become even more important in the future as the human kind perseveringly continues to destroy the natural environment. In some areas such as big conglomerations like Peking, Tokyo or Mexico City, the sky is not visible through a thick layer of smog and polluted air, making these areas inappropriate for growing plants for food. The attempt of the European Union to manufacture sustainable biofuels from colza-oil at large scale causes lack of farmland where crops could be grown and therefore, a significant rise in food prices occurs. Any technology that could make food production more efficient and less harmful to the natural environment could possibly save many lives in the future. Therefore, I am of the meaning that also a relatively simple environmental system such as growbox deserves a sophisticated control unit that could help designing optimal growing patterns. On figure 1.2 you can see an example of a small hydroponic system for growing tomatoes through the whole year and an example of aeroponic system called AeroGarden designed by AeroGarden Internation inc. The tomato (*Solanum lycopersicum*) is neither really a demanding plant nor too sensitive to atmospheric conditions but it's already being produced indoors in large quantities and therefore, the tomato seems to be a good example of a plant that is suitable for the designed growbox.

1.2 System description and requirements

Growbox is an enclosed environmental system that can be built from various materials such as wooden boards or just light aluminium construction covered with reflexive cloth. An example of light and cheap growbox construction developed by EastSide Impex company called Homebox is on figure 1.3. The aluminium pipes connected with plastic profiles form the supporting structure that is covered with rough airproof cloth. The inner reflexive layer is not made from the aluminium foil as someone might insist but it is a white reflexive cloth. We can see the ventilation air intake and exhaust and also a second air exhaust for mounting a separate lamp ventilation system called cooltube. On the floor of the growbox can be placed a plastic tank that can hold up to 100 liters of



Figure 1.3: Construction of a mobile growbox

water that might leak from the main water tank. This emergency tank is ideal place for further discussed water-leakage sensor that should warn the operating personell to take action before this tank is filled.

However, there are many materials from which a growbox can be built. It just has to be as air-tight as possible because of the ventilation system efficiency. There has to be a white inner reflexive layer and the construction material has to withstand higher humidity and temperature levels. The optimal size of a growbox equipped with a 400W high pressure sodium vapor lamp is about $100 \times 100cm$ base and 200cm height. These are the dimensions of the discussed Homebox but they may vary depending on the area that can be effectively covered by the used lamp. In the following sections I will briefly describe the most important factors that have to be kept in mind when designing an environmental control system and I will also introduce some technical details about indoor growing to the reader.

1.2.1 Lighting

The lighting system has to be adapted to the requirements of the animal or plant species. For example, certain reptiles need to heat themselves by the sun, so various bulbs emitting largely in infrared spectrum may be necessary to simulate their natural environment in a terrarium. In planting, the UV light is usually used during the blossom phase to

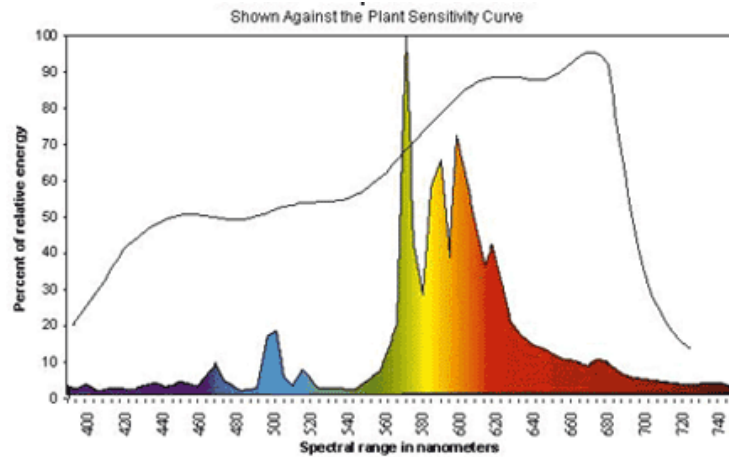

Figure 1.4: Spectrum of a high pressure sodium vapor lamp

stimulate the flower. Such UV light can be provided by specialized fluorescent tubes or UV emitting diodes. Various plant species need a different day/night ratio during its growth phases which has to be precisely simulated. For example plants from the family Euphorbiaceae have very strict demands on the lighting pattern in the flowering phase which makes it difficult to grow them outdoors in some geographical latitudes. Generally, we can say that for most commonly indoor grown plants the lighting period 18 hours light / 6 hours dark is optimal for the growing phase and lighting period 12 hours light / 12 hours dark for the blossom phase. The switching between these phases does not have to be gradual but the effect of slow period changing could be interesting when comparing more plant species. The light is usually used in conjunction with a reflector to control and intensify the light emission.

Generally we have to decide between a high pressure sodium vapor lamp and a fluorescent lamp when searching for the optimal lightning component for a growbox or a paludarium. The sodium vapor lamp is a gas discharge lamp which uses sodium in an excited state to produce light. This type of lamp emits light of wavelength that is useful for the photosynthesis but also produces significant amount of heat that has to be dealt with the ventilation system or the lamp has to have its own ventilation system called cooltube. In this case the lamp is placed into a tube made from borosilicate glass that does not absorb the important part of the spectrum emitted by the lamp and can sustain great temperatures. This tube has its own ventilation system which reduces the heating of the air inside growbox by the lamp. High pressure sodium vapor lamps are commonly used for indoor growing because the spectrum of emitted light is suitable for both the growing and the blossom phase and they are quite efficient with output $100lm/W$, up to $150lm/W$. The spectrum which can be seen on figure 1.4 can be also influenced by pulse operation. During the pulse there is significant broadening of the sodium lines at 449, 467, 498 and 568 nm and the development of a continuum from 400 to 450 nms, and also the appearance of visible mercury lines in lamps containing mercury. Optimum results with lamps in size ratings from 100 to 1000 watts are obtained with pulse repetition rates from 500 to 2000 Hz and duty cycles from 10 to 35%. The color temperature may be increased from the common value of $2050^{\circ}K$ to $2500^{\circ}K$ with reduction in lamp efficacy of only about 20% from conventional 60 Hz operation.

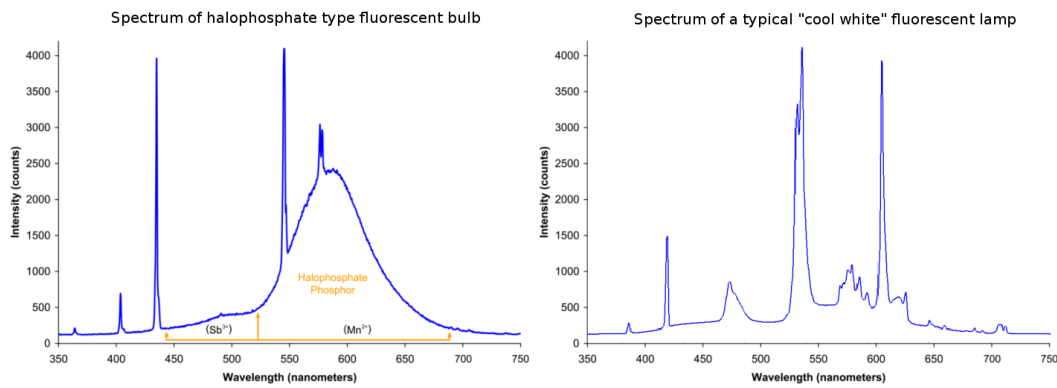

Figure 1.5: Comparing spectrums of the most common fluorescent lamps

The fluorescent lamp or fluorescent tube is a gas-discharge lamp that uses electricity to excite mercury vapor. The excited mercury atoms produce short-wave ultraviolet light that causes a phosphor layer to fluoresce producing visible light. There are many types of fluorescent tubes because the spectrum of emitted light can be influenced by the chemical composition of the fluorescent layer. On figure 1.5, you can compare the spectrum of the most common types of fluorescent lamps. You can see that the common "cool white" fluorescent tube has significant peaks in it's spectrum which makes it inappropriate for growing. If we use the modern technique called plant tissue culture or micropropagation we can use the halophosphate fluorescent tube for growing phase of explants and it is usable for the so called mother plant which is kept in stable growing phase by strictly keeping the 18/6 lighting cycle. In this case we also have to operate in aseptic conditions under filtered air which puts additional demands on the ventilation subsystem. Plants usually grow better when different light spectrums are used for different stages of plant's growth. The initial vegetative stage requires blue spectrum of light whereas the later blossom stage usually needs red-orange spectrums. On figure 1.6 you can see a graph illustrating the sensitivity of chlorophyll to various light sources. The lights can be bought by spectrum color specifically but that means separate electronic circuitry for both lamps. The fluorescent lamps designed for growing are sold under names Nurturelite or Envirolite but despite the effort to change their light spectrum they are still more suitable for growth than blossom phase. Some companies such as Sylvania GroLux produce full spectrum bulbs which satisfy plant's needs in all stages of growth. The most suitable, energy efficient and also most expensive is a dual spectrum compact fluorescent grow light. It is a type of electric lamp designed to promote plant's growth by emitting light spectrum appropriate for photosynthesis in both growth phases. The emitted light is similar to the sunlight allowing indoor growth with outdoor conditions. Natural daylight has a high color temperature around 6000 °K and we can compare how much the lamp matches the natural sunlight spectrum through the use of the color rendering index.

1.2.2 Temperature

The temperature can be a very important parameter for species that cannot adapt to other conditions than those found in their natural habitat. We have to be sure that the temperature won't get too high so the flower's leaves could be burnt. The higher

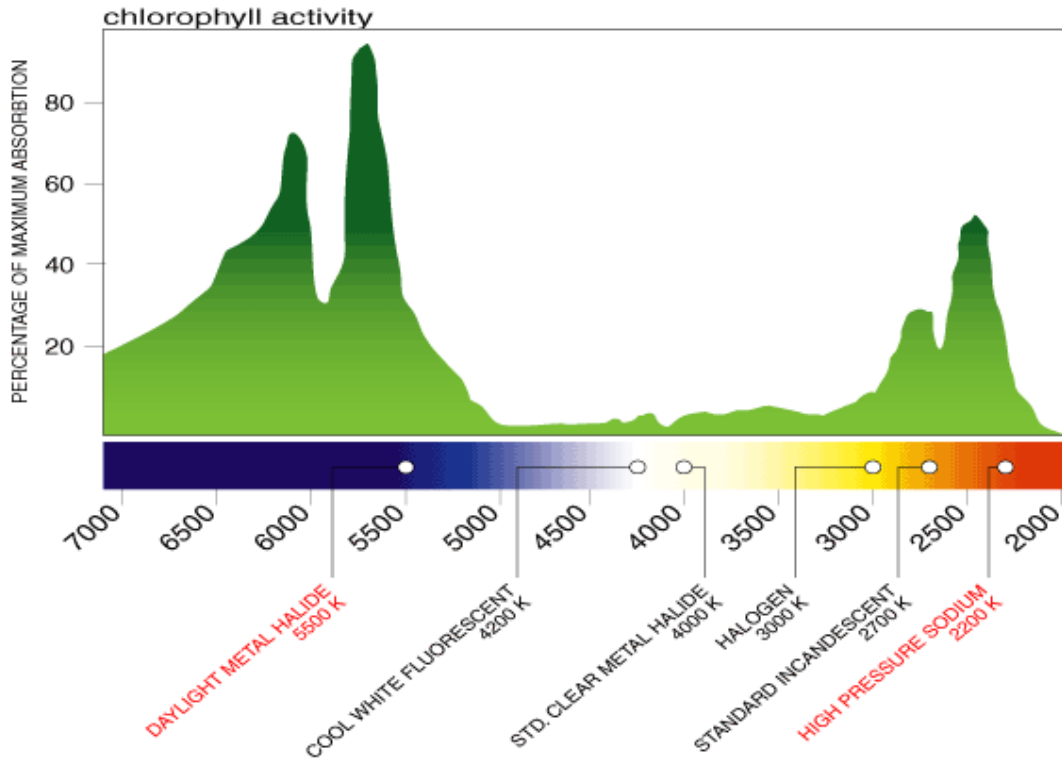

Figure 1.6: Graph of the chlorophyll sensitivity to various light spectrums

temperature also causes the humidity inside the growbox to rise. Therefore, it is difficult to control both values because the control actions would be sometimes in contradiction. The optimal temperature for most flowers is $25 - 27^{\circ}\text{C}$. The absolute maximum temperature that should set the ventilation to maximum speed is 35°C . The temperature also should not fall under 15°C but this situation is in usual indoor conditions very unlikely to occur and therefore, the designed control unit does not take any countermeasures against such temperature. The temperature of the air inside the growbox is vital but we also have to watch carefully the temperature of the water solution used for irrigation as some plant species have limited resistance to temperature variation near the plant's roots. This could be also done by the control unit. But since this is a quite easy task that can handle a simple thermostatically controlled electric aquarium water heater, it would be useless to waste output pins on this task.

Similar to lighting, a decrease in temperature might be needed for the simulated night periods. Such variation need to be coherent to those found in the natural habitats of the species.

Heating can be provided by several means:

- heating lamps or infrared lamps
- heating cords placed in the substrate or water reservoir
- a more complex equipment sending hot air inside such as controlled cooltube exhaust

1.2.3 Humidity

Many plants and animals have quite limited tolerance to the variation of moisture. The optimal relative humidity during the growing phase is usually higher than during the flowering phase. The plant species that are currently mostly grown indoors need relative humidity around 75% during growing phase and around 30% during the blossom phase. It is vital to keep the humidity low during the blossom phase to prevent molds and rust. The humidity level is also controlled by the ventilation subsystem and there is a strong correlation between the humidity level of the incoming air and the inner humidity level. The ventilation running on approximately 70% should achieve humidity level around 30% and the higher humidity during the growth phase should be provided with a humidifier along with lowering the ventilation throughput to 50%.

The regulation of humidity in closed environment can be done by several means:

- regular water pulverization
- water evaporation inside from a reservoir or the water circulation)
- automated pulverization systems and humidifiers

1.2.4 Watering and fertilization

The sufficient watering is essential for successful indoor planting. The control algorithm for the irrigation subsystem depends on the technical implementation used. Today, the most effective way of indoor planting is hydroponics. More details about this progressive planting technique can be found in [7]. The difference between hydroponic and regular planting is, that in hydroponics, the plant is not placed into soil, but into a substrate from mineral wool or perlite and it takes all the inorganic ions essential for it's growth from the water.

These are the most common irrigation techniques used indoors.

- Drip irrigation
- NFT
- Bubbler
- Aeroponic apparatus

When using Drip irrigation the water is delivered to the roots of plants, drop by drop. The plants are usually placed in a rockwool cube and the water with fertilizer flows through the cube into the main reservoir from there it is pumped into the upper smaller reservoir and the cycle repeats.

The NFT - Nutrient Film Technique is the most commonly used hydroponics technique. A constant flow of nutrient solution is pumped from a tank over the roots of the plants in a tube or tray and then returns to the tank. There is no growing medium other than that which was used to propagate the plant from a seed or cutting. The lack of a growing medium means that the roots of the plants are prone to drying out if the pump stops working. Therefore, the pump has to be checked and in case of failure the alarm has to be triggered. The tank must be checked regularly to adjust pH and nutrient strength measured in EC.

The hydroponics system is called a Bubbler when the roots of the plants are placed in the water solution and a continuous flow of air bubbles goes through these roots.

An opposite approach would be aeroponic growing. The plants are grown in an air or mist environment without the use of soil or an aggregate medium. Unlike hydroponics, which uses water as a growing medium and essential minerals to sustain plant's growth, aeroponics is conducted without a growing medium and is said to be more energy and water efficient.

A very important factor is the acidity or alkalinity of the water measured in pH. The optimal pH level depends on the plant species grown, but usually the pH should vary from 5 to 5.5. The second main attribute that needs to be checked regularly is the electrical conductivity which is in hydroponics systems often used to monitor the amount of nutrients, salts or impurities in the water. The EC of a solution is highly temperature dependent and therefore, it is important to use a temperature compensated measuring instrument.

Over a limited temperature range, the way temperature affects conductivity can be modeled linearly using the following formula that was published in [5]:

$$\sigma_T = \sigma_{T_{cal}}[1 + \alpha(T - T_{cal})]$$

where T is the temperature of the sample, T_{cal} is the calibration temperature, σ_T is the electrical conductivity at the temperature T , $\sigma_{T_{cal}}$ is the electrical conductivity at the calibration temperature T_{cal} and α is the temperature compensation slope of the solution which is for most naturally occurring waters about 2%/°C. Usually the EC may vary from 0.5 for pure water to 3 for water with high amount of added fertilizer. It is also true that there is correlation between EC and pH and we can generally say that the lower the pH level is, the higher EC is measured. However, this correlation is unwanted because it is useless for precise pH calculation and it distorts our idea of fertilizer concentration.

The Flower farm control unit has one pin designated for input from pH or EC measuring devices. These devices are unfortunately quite expensive and I don't expect many people that would want to measure these values automatically because they don't change dramatically and can be checked manually during regular maintenance. The regulation of these quantities, for example by using a microdripper with acid or alkaline solution for controlling pH, would be very expensive and risky because every small mistake in the dosing mechanism could have fatal results. On table 1.1 you can see the optimal concentration of commonly indoor grown plant species as it was published on [3].

1.2.5 Ventilation

Ventilation is not just important for air circulation but also to prevent the growth of mold and bacteria. This is especially important in warm and humid terrariums or growboxes because the circulating air reduces the local temperature and humidity. The traditional method consists of placing a so called UFO radial fan at a low level and another at a high level thus allowing the optimal air circulation. More on ventilation of indoor gardens can be found in [8]. The most important characteristic of the ventilation subsystem is reliability. The precision of the control pattern is not so important during normal working conditions because the airflow has to be relatively stable. However, in case of overheating or too high humidity the airflow has to be higher to ventilate the hot air out of the system and on the other side when a fire occurs the ventilators should be stopped. Some strains,

| | Growth | Bloom |
|------------|---------------|--------------|
| Nitrogen | 5.2% | 4.2% |
| Phosphorus | 0.7% | 0.7% |
| Potassium | 4.0% | 5.2% |
| Calcium | 1.8% | 1.5% |
| Magnesium | 0.6% | 0.6% |
| Sulfur | 0.9% | 0.9% |
| Fe | 0.05% | 0.05% |
| Mn | 0.02% | 0.02% |
| B | 0.032% | 0.032% |
| Zn | 0.002% | 0.002% |
| Cu | 0.0015% | 0.0015% |
| Mo | 0.0009% | 0.0009% |

Table 1.1: The optimal concentration of chemicals in water tank

especially cultivars of *C. sativa* can give off strong odors as they grow. If these odors are unwanted a carbon filter can be used for air filtering.

These are the ventilation components used in growboxes:

- A pair of UFO ventilators
- Cooltube using separate ventilation for the lamp.
- Carbon air filters



Figure 1.7: The UFO radial ventilator

It is also possible to positively influence the growth with an additional CO_2 supplement. In this case, excessively intensive ventilation is unwanted during the supplementing process and the ventilation control algorithm would have to be more complex. The temperature would have to be as low as possible before the start of the supplementing process because the growbox would heat itself much faster with the reduced ventilation.

2 Analysis and hardware design

In the following sections I will briefly describe main elements of the hardware I designed and provide some technical details about used electrical parts and circuits.

2.1 Measuring devices and peripherals

In this section I will discuss the sensors that will have to be connected to the control unit in order to make it work as growbox controller. In some cases additional circuitry (ie. an amplifier) is needed for handling the sensor's output. A good overview of possible approaches is in [6] and [9].

2.1.1 Temperature sensors

On figure 2.1 you can see four categories of temperature sensors that seem to be the best choice from the <http://www.tme.eu> eshop or [4] datasheets. The cheapest LM335AZ sensor is shipped in TO-92 or SO-8 package and is designed for temperatures from -40 to 100 °C which means that the scope of operating temperature will cover the sensor's range by approximately 14 percent. This fact is not a big disadvantage because of the linear voltage output and typical error less than 1 °C. There is an easy method of calibrating the device for higher measuring accuracy. The output of the LM335 is proportional to the absolute temperature with the extrapolated output of sensor going to 0V at 0°K which equals -273.15 °C. Errors in output voltage versus temperature are only slope. Thus the calibration of the slope at one temperature corrects errors at all temperatures. The sensor's output is given by the equation:

$$V_{out} = V_T + V_{T0} \frac{T}{T_0}$$

where T is the unknown temperature and T_0 is the reference temperature in °K. Nominally, the output is calibrated at $10mV/°K$. Precautions should be taken to ensure good sensing accuracy. As in the case of all temperature sensors, the accuracy can be decreased by self-heating. The LM135, LM235, and LM335 should operate with a low current but sufficient to drive the sensor and its calibration circuit to their maximum operating temperature. If the sensor is used in surroundings where the thermal resistance is constant, the errors due to self-heating can be externally calibrated. This is possible if the circuit is biased with a temperature stable current. Heating will then be proportional to Zener voltage and therefore also to the temperature. In this way the error due to self-heating is proportional to the absolute temperature as scale factor errors.

The NTC-K45-10 sensor has even bigger measuring range from -55 to 125 °C, resistance at 25 °C is $10k\Omega$, resistance accuracy 10% and power rating of $450mW$. This temperature sensor is in a shape of M3 screw with low thermal resistance aluminium housing insulated from the electrical circuit. It is designed to be screwed-in in a heatsink which could be useful for measuring for example the temperature of the cooltube lamp cover but for our purpose the heatsink would bring in unwanted hysteresis and slower the response time to sudden temperature peaks.

Thermoelectric temperature detector is a device sensitive to infrared radiation and therefore, it can be used to measure temperature even of the flower's leaves which could be a

graet advantage in research. The output depends on the angle of incidence which might be a reason for replacing the leaf with a sample of homogenous material in fixed distance from the sensor. The TPS434G9 thermopile detector manufactured by PerkinElmer company is fitted with the G9 filter for range 8 - 14 μm , which enhances measurement accuracy and resistance against interferences and therefore, it is characterized by good electrical parameters, high repeatability and time stability. Each detector is fitted with thermistor embedded in the structure, which enables thermal compensation. The active element is made of silicium based thermopile and its sensitivity is measured for black body in temperature 500 °K without optics. However, the use of this quite expensive sensor would require additional circuitry which makes it inappropriate for regular use in growboxes without any research aspirations.

At least the resistive PT106051 sensor based on glass substrate could be a good choice because of it's low price and low operating current. It has a wide operating temperature range from -50 to 500 °K which increases the measuring uncertainty but we still should consider using this sensor.

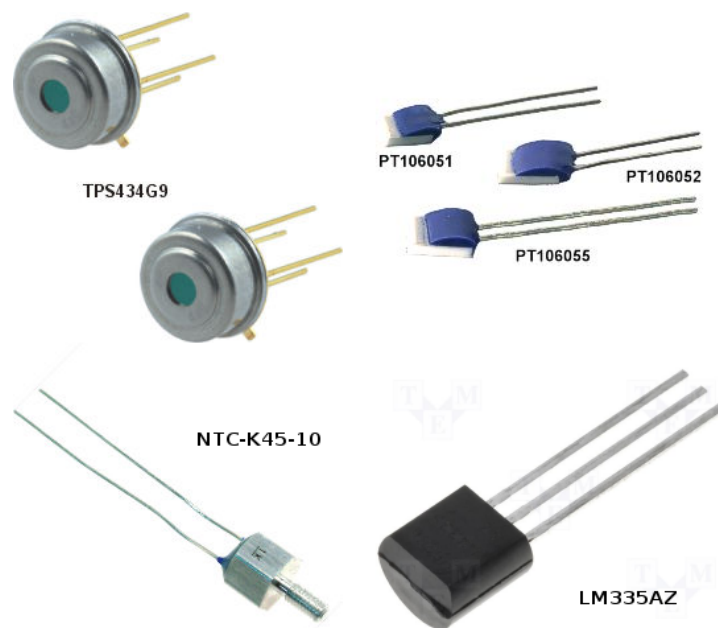

Figure 2.1: Temperature sensors overview

2.1.2 Humidity sensors

Humidity sensor is important for measuring the humidity of the air inside the growbox because plants usually need different humidity during the growth phase and the flowering phase. The humidity depends on the temperature inside the growbox, the irrigation algorithm and the ventilation. Generally the only way of controlling humidity is a humidifier or through the ventilator speed because the temperature is mainly influenced by lighting bulb with determined switching period. Therefore, the accuracy of humidity measuring is not crucial. We can choose between various types of sensors that you can

see on figure 2.2. The most sophisticated and most expensive are sensors HIH-4000-002 or HIH-4000-004 with linear voltage output manufactured by Honeywell. Cheaper and more noise-resistant are sensors SHT71 or SHT75 with digital output manufactured by Sensirion. For purpose of this project, the use of sensor modules SY-HS-220 or SY-HS-230 looks like optimal choice because of their low price, narrow hysteresis, wide operating range and relatively good sensitivity and linearity. The sensors used in these modules can be also ordered separately from SyHitech.

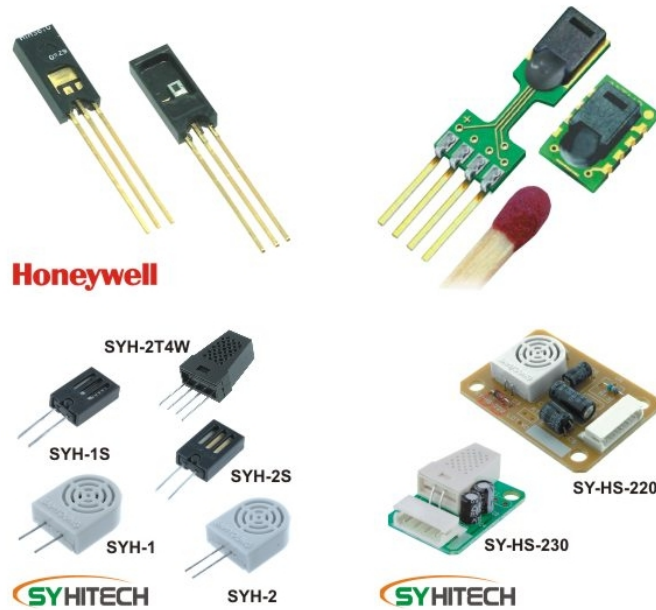

Figure 2.2: Humidity sensors overview

2.1.3 Alarm triggering devices

In this section I will describe the sensors that can be used for triggering the alarm input of the microprocessor. The alarm can be triggered by three causes, that are further described in the following sections. Outputs of these typically three sensors are connected to TTL NAND circuits according to the scheme shown on figure 2.3.

2.1.3.1 Lighting system failure detector

A phototransistor or photoresistor is being used to detect failure of the lighting subsystem which might be critical for the plants when lasting longer than approximately two days but such failure should be detected and handled as soon as possible. There are no accuracy requirements because we just need to verify that the lighting system is working during day periods. For example when using a VT43N1 photoresistor which can be seen on figure 2.4 no complicated additional circuitry is needed and no sophisticated input handling has to be performed. This photoresistor has the resistivity approximately $300k\Omega$ in dark and $8k\Omega$ when illuminated by $10lx$. Under direct light of a lamp used for indoor growing the resistivity is likely to drop under $1k\Omega$. Thus we can connect this photoresistor

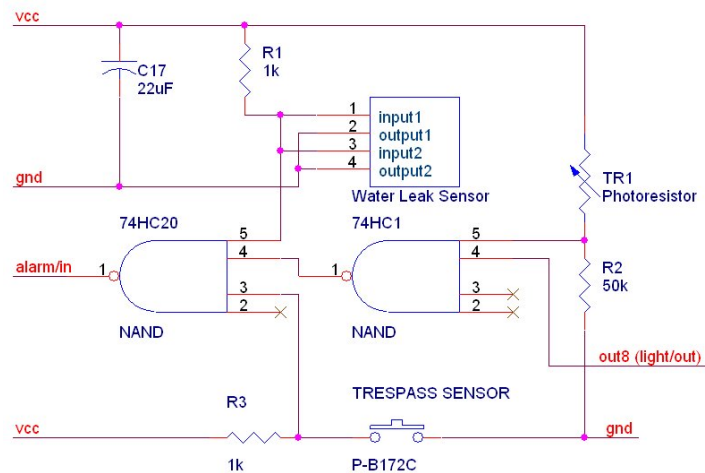

Figure 2.3: Scheme of the alarm triggering circuitry

to the alarm triggering circuit scheme which is shown on figure 2.3. If we use a resistor with resistance approximately $50k\Omega$ as on the scheme, the voltage on the photoresistor will approximately be $4.285V$ in dark and $0.09V$ during the day phase.

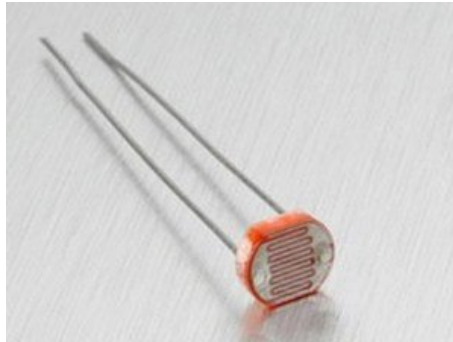

Figure 2.4: VT43N1 photoresistor

2.1.3.2 Water leak sensor

The water leak sensor used in this project is the simplest sensor of this type that can be either bought or made by drawing suitable pattern on a piece of blank PCB as you can see on figure 2.5. The sensor triggers the alarm when water reaches the PCB making a conducting connection between the sensor's input and output. This causes a LOW signal on the output that is setting on the alarm through the alarm triggering circuit.

2.1.3.3 Trespassing sensor

The growbox could become a target of thieves or vandalism when standing in a weakly secured area. Therefore, a trespassing sensor could prove useful for detection of unauthorized access or improper manipulation. On figure 2.6, you can see a P-B172C switch that has a switcher with a small wheel. This switch is stable when turned off and it has



Figure 2.5: Water leak sensor

to be pushed to turn it on. This can be used for securing doors or to detect manipulation with the lighting tube currently being turned on when the input leads to a NAND circuit along with the light detecting circuit's output. With the keyboard and LCD connected, the user could set a code for deactivating the trespassing sensor.

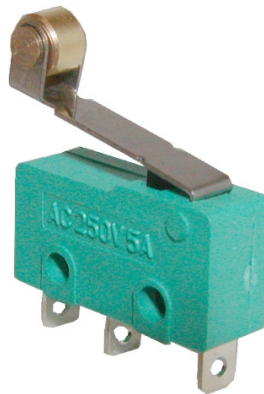

Figure 2.6: Trespassing door sensor

2.2 Microprocessor ATmega32

As a heart of the control unit I decided to use an ATmega32 microprocessor in DIL40 case because it is easy to solder this type of case for do-it-yourself users and this type of microprocessor is also quite robust and relatively immune to electromagnetic disruption. The pinout of this microprocessor with pins labelled according to their use in circuit can be seen on figure 2.7 or in [1] datasheets. It has $32kB$ of program FLASH memory and $2kB$ of SRAM memory where program data can be stored. It is equipped with two 8bit timers, one 16bit timer and eight AD converters. The ATmega32 processor is a product of Atmel Corporation, one of biggest manufacturers of advanced semiconductors. Therefore, I assume that the production of these well-documented microcontrollers will last long enough so this project could be useful many years after its creation. There are faster microcontrollers with a bigger memory on the market, but the price of ATmega32 is very low, the development IDE AVR Studio is free and there is quite a big user community. This was for me a benefit during developing process because I could find some help in [10] with issues that occurred during programming. I would prefer a Freescale microprocessor from my current point of view but the decision has been already made. I also considered

use of an ARM 32bit processor but I decided that it would be unnecessarily complicated and it would be in contradiction with meaning of this work as it was described in Abstract. For programming the microcontroller through the SPI interface I used AVR Dragon device developed by the Atmel corporation. The used microcontroller and other electrical parts are quite robust and are likely to maintain good performance in exacting conditions with high humidity and last but not least I am of the meaning that it's not good to use unnecessarily precise and complex solutions for control of processes whose failure might be fatal even if it's only flowers whose life is at stake.

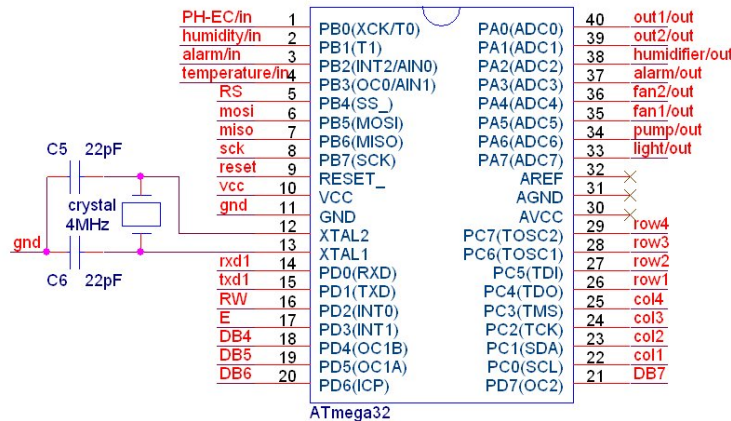

Figure 2.7: ATmega32 microprocessor pinout

2.3 Circuitry design

I made the schematic design which you can see on figure 2.9 in application Capture from the OrCAD 10.0 bundle by EDA Software with help of the book [11]. It is quite robust application that has many features useful for design of complex multilayer boards but for this relatively simple single-layer design these features were of no use and made the design unnecessarily complicated compared to the Eagle application by CadSoft. However, I'm glad that I used OrCAD because I learned how to use more sophisticated hardware design tool which can be along with libraries that I created an advantage in the future.

On figure 2.8 you can see the schematic of the power source electronic circuitry. There is a 1N5818 rectifying diode and a LM7805 voltage regulator for use with 7-24V input voltage and we can see also the second voltage regulator HT7133 which needs to be set with its blocking capacitors only when we want to use a MMC memory card as output. When we want to use a 5V adaptor as power input we have to short-circuit the rectifying diode and the LM7805's input and output to avoid voltage loss that would prevent the circuit from working. These parts are usually already present in the adaptor and I added them to the design to make it possible to power the control unit from different source which could typically be industrial 12V power source.

There is a reset button that is placed on the PCB next to the power connector. This is not very important because you can reset the circuit by pulling out the power supply connector but the button is more elegant and it was useful for development. Also the

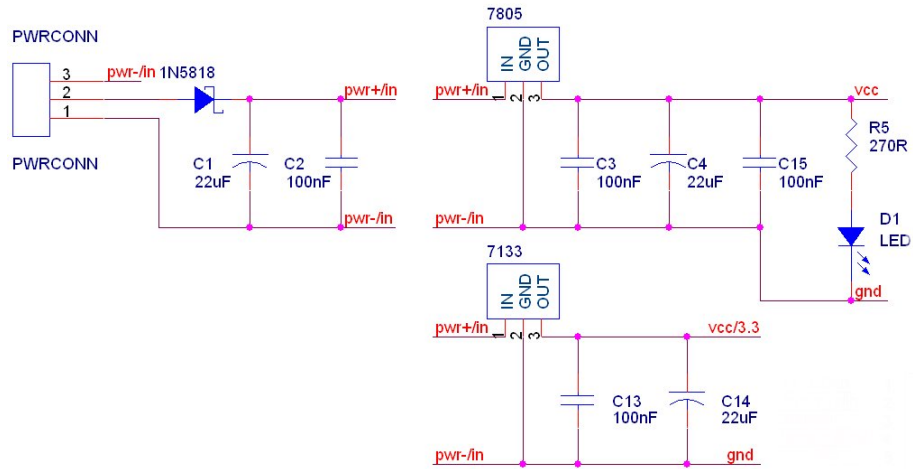

Figure 2.8: Circuitry scheme of power supply

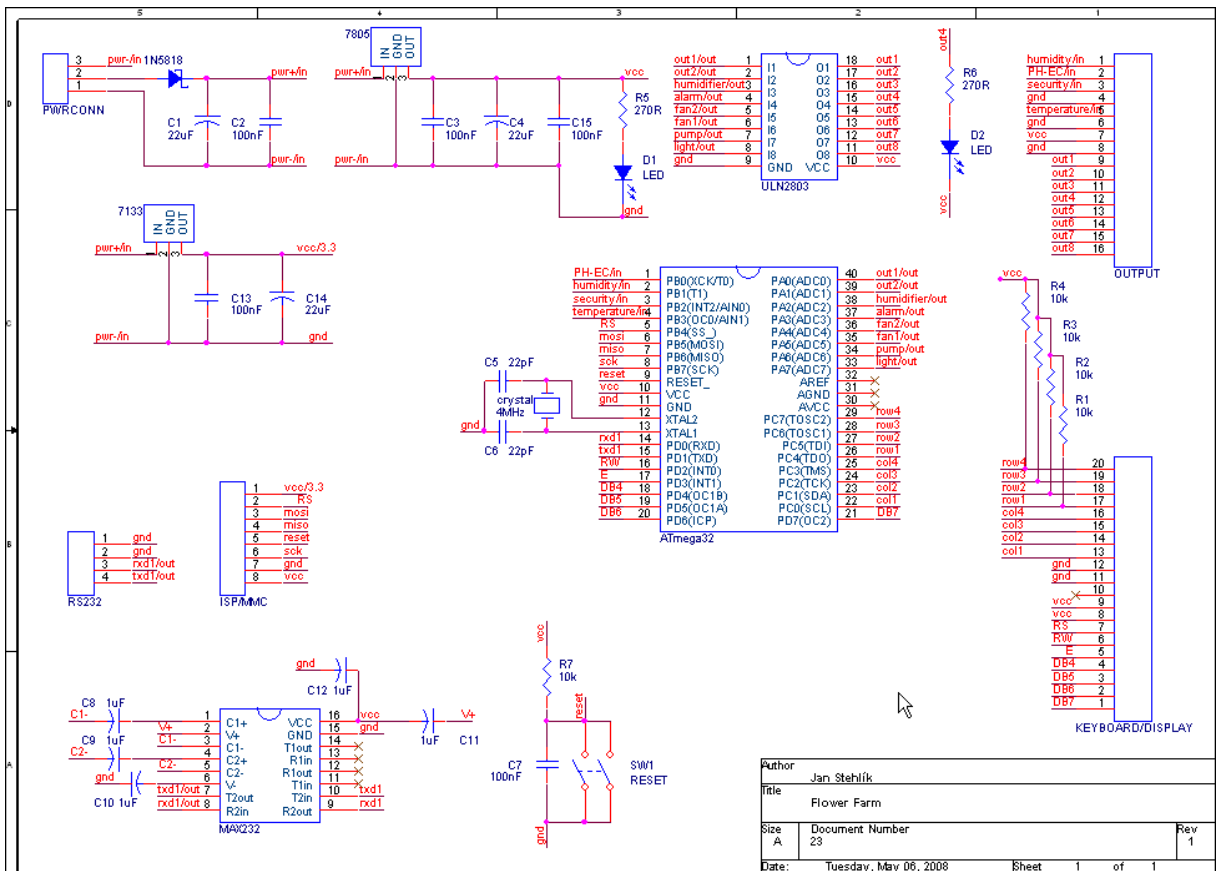

Figure 2.9: Complete circuitry scheme of the control unit

reset can be led with wires to another room which may prove useful. The device will be fully functional without this button but the capacitor C7 should be set to avoid accidental reset due to electromagnetic disturbance.

You can see two status LEDs with their resistors R5 and R6 that indicate the state of the system. The green LED D1 is on all the time the device is working and the red LED is on only when the alarm signal is triggered. The red alarm LED D2 is parallel to the alarm signal output which can be connected to a more powerful light or sound source that would ring up the operating personnel when a dangerous situation could occur such as water leakage, malfunctioning main lamp or suspiciously high power consumption. The sensors and circuitry needed to detect these conditions such as phototransistor are not a part of the control unit and they were be briefly described in section 2.1.

The heart of the control unit is represented by an ATmega32 microprocessor running on frequency 4MHz given by the crystal oscillator with capacitors C5 and C6. All the outputs of the ATmega32 are led through 8 channel darlington sink driver ULN28003. This integrated circuit has the maximum output current for single channel 0.5A. If we want to be sure that nothing goes wrong, it is good to connect only LEDs directly to it and all more power-consuming devices should have their own switcher such as a thyristor or relay triggered with one of the ULN2803's channels. The MAX232 dual driver/receiver and pinout of the RS232 interface is further described in section 3.1.

On figure 2.9 you can also see 20 and 16 pin connectors for input/output peripherals. The resistors R1, R2, R3 and R4 serve for limiting the current to keyboard. On the 20 pin connector there are also additional power supply wires +5V and GND for keyboard lighting.

3 Software design and user interface

In the following sections I will briefly describe the means of communication between the user and the control unit. The source codes of the control unit's firmware and the Flower Farm application are written under the GPL license and are well arranged to ease orientation of possible participants on this project. I would like to continue work on this issue and make the control pattern of the control unit fully programmable through the graphical user interface. However, designing the software was not the main aim of my bachelor thesis which concentrates on hardware design.

The contact between the user and the control unit is supposed to be done by 4x4 keyboard and a LCD display. These devices are connected to the 20 pin connector and can be seen on figure 4.1. I have experimented with using an LCD display and a keyboard but I encountered various problems during programming the input/output routines that would take too long to overcome and therefore, I decided not to leave the half-implemented code in the final source code of the firmware and used the RS232 interface for primary input/output. This issue will be worked on in further development of this project.

The next output option of the device is using a MMC memory card which needs to be powered with 3.3 volts. In that case we need a HT7133A 3.3 volt regulator to be soldered on the PCB with it's own blocking capacitors C13 and C14. However, the MMC memory card doesn't have to be used necessarily and in that case, the 3.3 volt regulator and it's blocking capacitors are not needed. The output to memory card was added to the hardware design just as an option to write large amounts of measured data in case the control unit was used for research purposes where high granularity of measured data is needed. The output routine is not implemented, but it has been declared in the source code of the firmware.

3.1 UART communication

The communication between the PC and the control unit can be established through the RS232 interface. The correct pins of the Atmega microprocessor on the control unit are connected to the PC's serial port and the communication can start through the HyperTerminal application that is a usual part of every Windows operating system and it has also an equivalent called Minicom on Unix based systems. When using this type of connection to the PC, the output looks similar as it would look like on the lcd and navigation in the menu is done by "W,S,A,D" keyboard keys.

For serial communication with a PC or a laptop, the microprocessor's UART is used with the MAX232 Driver/Receiver. The transfer baud rate is set to 9600baud with 8 data bits, no parity and one stop bit. The RS232 interface and MAX232 pinout can be seen on figure 3.1. It is also necessary to solder the C8,C9,C10,C11 and C12 capacitors with the correct polarity to make the MAX232 work properly.

3.2 The Flower Farm application

I developed a .NET application called Flower Farm that should make communication with the control unit easier through graphical user interface. This application is able to display measured data and set parameters of the control pattern, but I was not able to make the serial connection work properly until now. This will be a task for the continuous

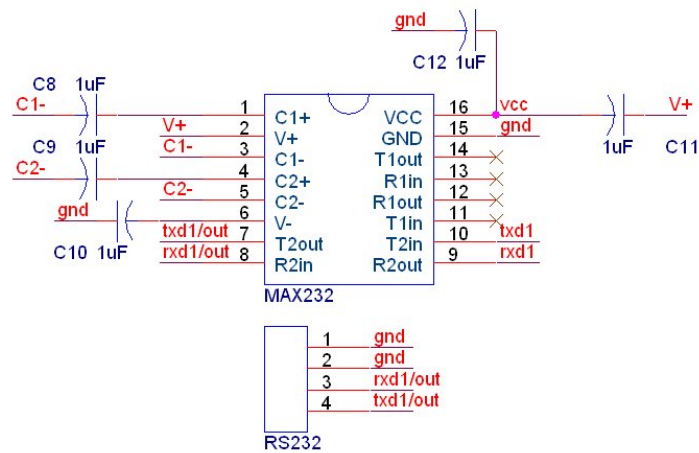

Figure 3.1: Scheme of the RS232 interface pinout

work on this project, because this concept can only be successful if there is a user friendly alternative to text-oriented hyperterminal user interface. I have designed a very simple communication protocol to be used with the .NET application that I have developed for this purpose using Microsoft Visual Studio 2005. Unfortunately there was not enough time to implement this protocol in the current version of the control unit's firmware. At this stage the Flower Farm application just determines whether the device is present and establishes the connection.

4 Implementation of the hardware design

The printed circuit board of Flower Farm control unit prototype was manufactured by Pragoboard s.r.o. I encountered some problems with insufficient diameter of drilling that was caused by interferences in fitting and I had to enlarge some drilling with a minidrill. I checked all the connections on the printed circuit board with a simple acoustic conductivity tester and found that one of the connections is broken and has to be replaced with a wire. Aside from these defects, the printed circuit board was manufactured precisely and I was satisfied with the durability of the board.

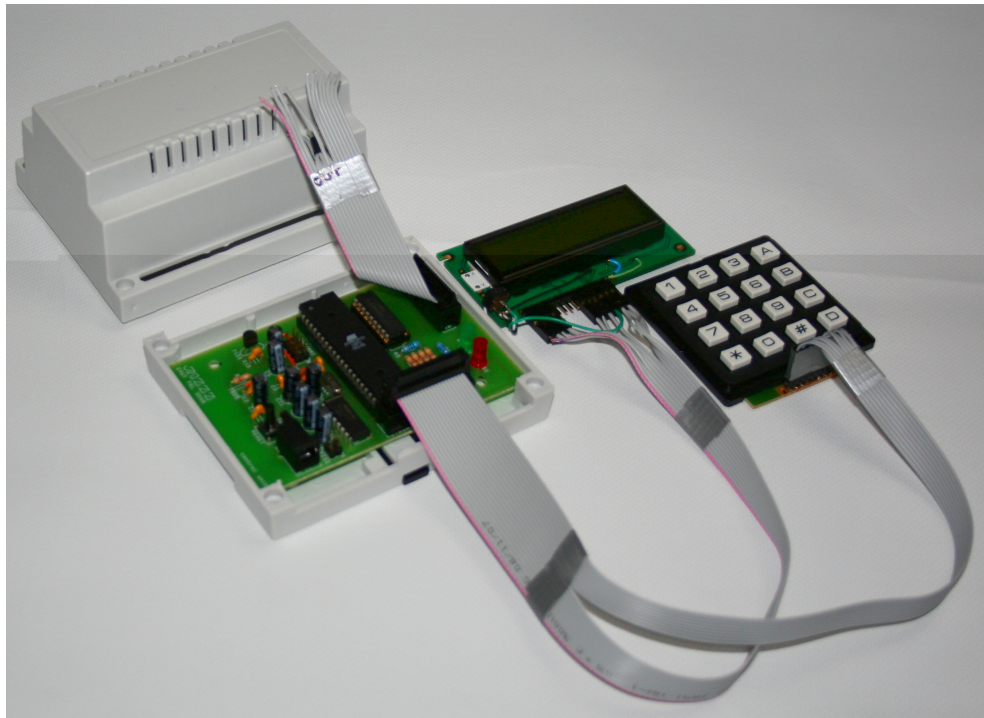

Figure 4.1: A picture of the completed control unit

On figure 4.2 you can see the printed circuit board with two used layers: the top route layer and the service print layer. The top and bottom solder masks are a part of attached manufacturing data and can be also found in the attachment.

On figure 4.3 you can see all connections used in the design, except for the one connection that could not be made on printed circuit board in order to maintain single-layer design. This connection is present in the attached project documentation in layer "top" for the case of using double-layer manufacturing process. However, this connection is not very important if we don't want to use MMC card or the additional IO pin. The printed circuit board exactly fits the designated plastic case but the holes for screws have to be a bit enlarged. The board fits the case so well that it seems sufficient to only glue it to the case with hot silicone glue. The plastic case can be seen on figure 4.1 with the LCD display and the keyboard connected to the control unit. I have chosen this type of plastic case from the <http://www.gme.cz> eshop catalogue because it can be easily attached to a DIN rail. There is also a type of equally sized case with a hole in the front panel for the LCD display.

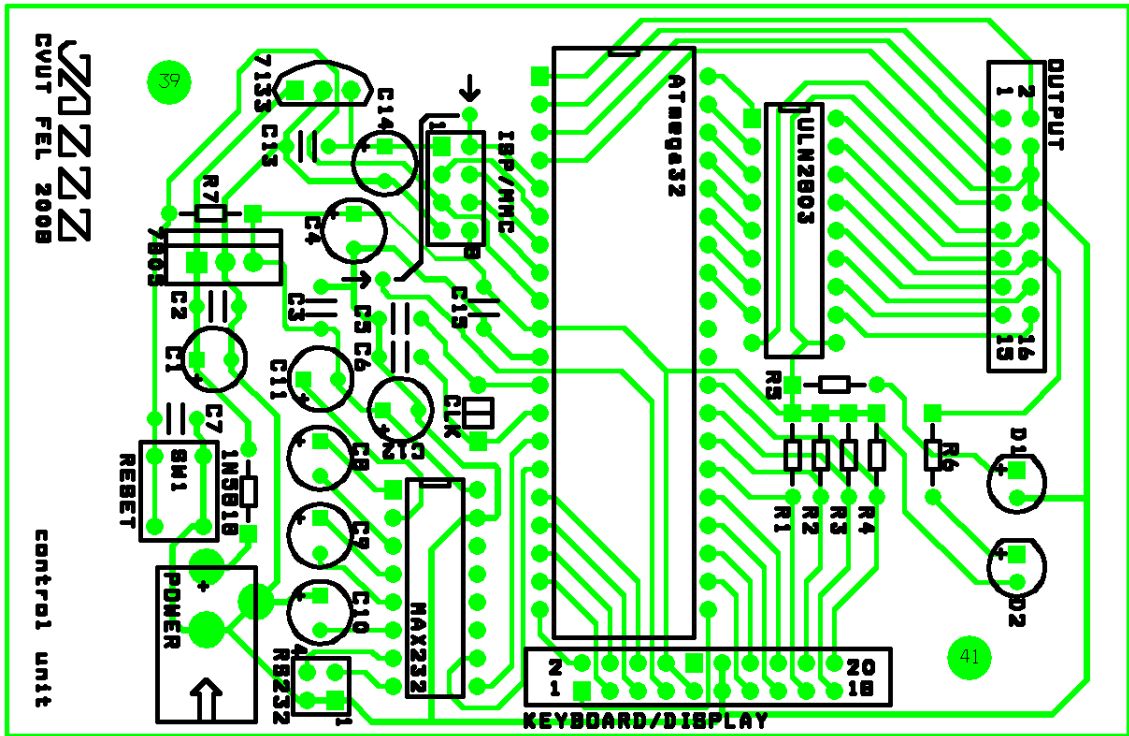

Figure 4.2: Printed Circuit Board of the control unit

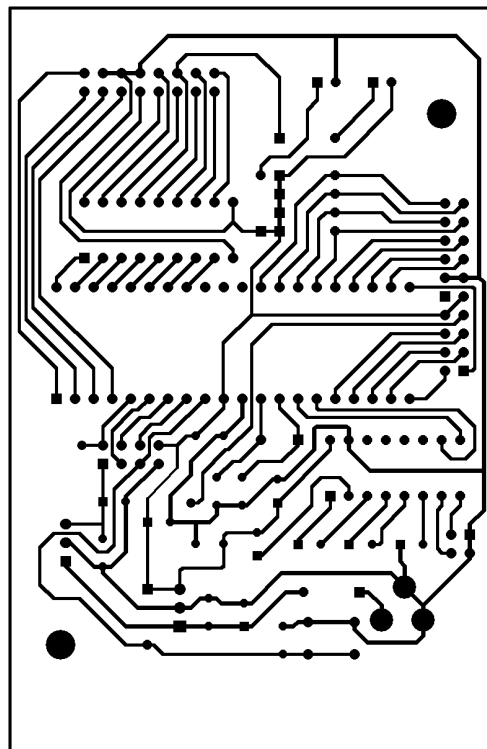

Figure 4.3: Route layer of the control unit

5 The control unit testing

Testing the control unit in a complete growbox system would have to last at least 4 months and it would be useful to have some kind of reference which could prove, that the used controll pattern really makes a significant difference in the growth speed or quality of the plants. This was not possible due to insufficient time and it was not even an objective of this work. The control unit was tested in two steps that are further described in following sections:

- Electrical and mechanical testing
- User interface testing

5.1 Electrical and mechanical testing

After soldering all the parts on the printed circuit board, I tested their mechanical durability under medium pressure. Especially the power connector has to be firmly connected to the board, which was achieved by glueing the connector before soldering. All the parts seemed to be soldered firmly so I also tried fall resistance of the control unit by dropping it from height of approximately 1 meter on a hard floor and everything was still working which approved that all used parts are robust and likely to maintain stable and reliable operation.

The electrical testing was done with usual acoustic conductivity tester again after soldering all the electrical components, to be sure that everything is soldered properly. I also had to test the cables connected to the control unit which proved very useful because the self-clamping electrical connectors are not 100% reliable.

5.2 User interface testing

The user interface of the control unit is very simple because implementation of any advanced settings would be useless without having the control pattern already completely implemented. The user interface was tested along with the RS232 interface with positive results. It is possible to communicate with the control unit through the Hyperterminal application and also the communication with the Flower Farm application can be established. However the control unit is yet not fully prepared to for use in a real system because sensor input routines have to be implemented after the appropriate sensors for particular application are chosen. At this point the control unit is a finite state machine that has all important routines declared and is ready to be adjusted for a particular utilization.

6 Conclusion

Work on this project was for me a big challenge and it made me learn a lot about hardware design in OrCAD 10.0 and microcontroller programming in assembler and gcc. I got lots of significant experiences during programming the communication software in .NET and I also learned how to write a larger thesis in typographic system TeX with help of [2]. I studied and described the technical means of controlled indoor plant cultivation and I believe that it will become increasingly important over time.

I designed a simple control unit for a small automated hydroponic system and described various peripherals that might be used in order to create a complete controlled environmental system for plant cultivation. I have also created an application with user friendly interface that could be used for programming the control unit. However this feature is yet not completely implemented. The main meaning of this project is to offer a simple control unit design as an alternative to expensive commercial systems and the hardware design was made with respect to low precision techniques that are used by do-it-yourself manufacturers. Therefore, the thesis is written in English to possibly find some users in small biological research facilities or households around the world. I hope that somebody will take advantage of this opensource solution and I plan to continue working on this project by creating a simple how-to for unstudied people written in english that will be based on this thesis.

I would like to continue working on this issue and to design a more compact control unit using SMD technology and an ARM processor that could communicate via ethernet or wireless connection with its operator. But this device would have to be designed for more complex use such as universal remote measuring unit. This project was for me a first step to achieve this goal.

7 Bibliography

- [1] Collective Authorship. Atmel corporation - datasheets of microcontrollers and advanced semiconductors. <http://www.atmel.com//>.
- [2] Collective Authorship. Cstug - cs tex users group. <http://www.cstug.cz/>.
- [3] Collective Authorship. Hydroponics knowledgebase and e-shop. <http://www.greenhome.cz/>.
- [4] Collective Authorship. St microelectronics - datasheets of sensors and semiconductors. <http://www.st.com/>.
- [5] Collective Authorship. Wikipedia - world's largest free encyclopedia. <http://cs.wikipedia.org/>.
- [6] J. Vedral J. Fischer. *Elektronické obvody pro měřící techniku*. Vydavatelství ČVUT, Praha, 1999.
- [7] Karl-Heinz Opitz. *Hydroponie*. Nakladatelství Jan Vašut, 1st edition, 2008. in Czech.
- [8] Susan Slobac. Ventilation for indoor gardens. <http://ezinearticles.com/>, 2008.
- [9] M. Sedláček V. Haasz. *Elektrická měření - Přístroje a metody*. Vydavatelství ČVUT, Praha, 2000.
- [10] V. Váňa. *Mikrokontroléry ATMEL AVR - Programování v jazyce C*. Nakladatelství BEN, Věšínova 5, Praha 10, 2003.
- [11] V. Záhlava. *OrCAD 10*. Grada Publishing a.s., U Průhonu 22, Praha 7, 2004.